

# Instructions for the program MIRA

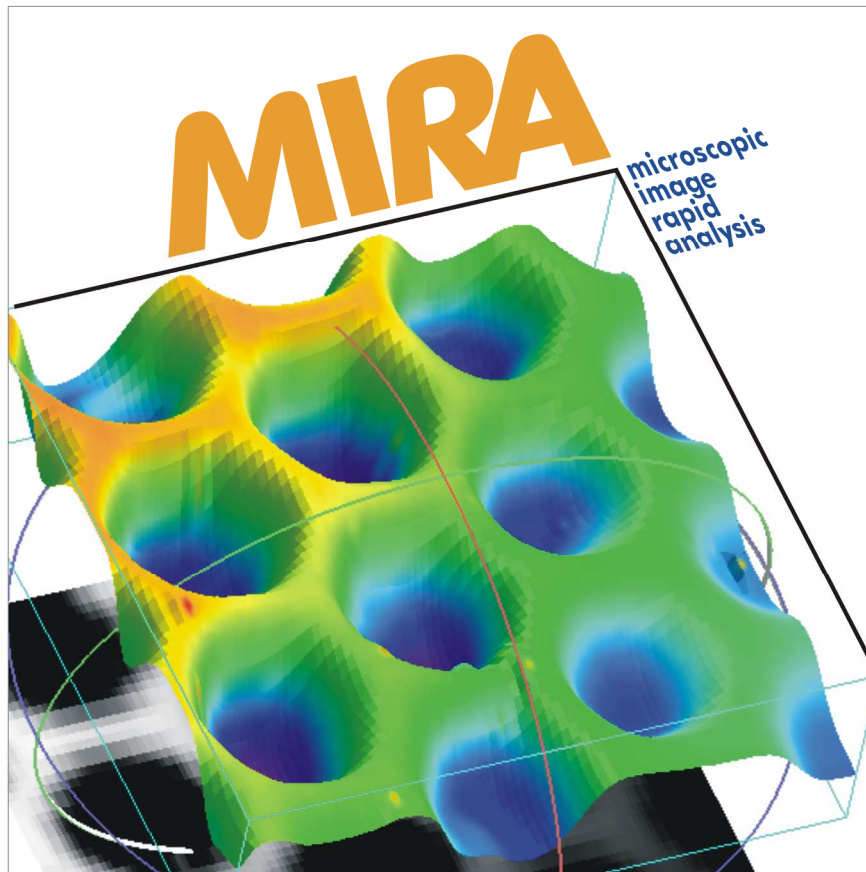

(Microscopic Image Rapid Analysis, span. "Look!")

Last Changes: 29 May 2021

1	Installation of MIRA.....	6
1.1	Preparation of the PC.....	6
1.2	How to install MIRA.....	7
1.3	How to uninstall MIRA.....	10
2	First look at MIRA.....	10
2.1	Launch MIRA .....	10
2.2	Customizing MIRA .....	12
3	Single Plot .....	14
3.1	File.....	15
3.1.1	Open File .....	15
3.1.2	Change default paths .....	15
3.1.3	Save/Load formatting .....	15
3.1.4	Save to/Load from IDL (Interactive Data Language) binary.....	16
3.1.5	Import form ASCII.....	16
3.1.6	Export to ASCII .....	17
3.1.7	Selection of graphic format .....	17
3.1.8	System printer setup.....	19
3.1.9	Print .....	20
3.1.10	Start MULTIPLT .....	20
3.1.11	Add to MULTIPLT .....	20
3.1.12	Exit.....	20
3.2	Tools .....	21
3.2.1	XLoadct .....	21
3.2.2	XPalette .....	21
3.2.3	Show header .....	23
3.2.4	iSurface .....	23
3.2.5	iSurface (Shaded).....	26
3.2.6	iContour.....	26
3.2.7	ilmage.....	27
3.2.8	iPlot.....	27
3.3	Data.....	29
3.3.1	Subsets.....	29
3.3.2	Resize array.....	31
3.3.3	Arithmetic.....	32
3.3.4	Data cutoff .....	32
3.3.5	Rotate array.....	35
3.4	Plot format .....	36
3.4.1	Handle volume data (old SECMx data files) .....	36
3.4.2	Handle volume data (new SECMx data files) .....	38
3.4.3	Create view .....	43
3.4.4	Plot-dep. margin.....	44
3.4.5	Plot region.....	46
3.4.6	Skirt .....	46
3.4.7	Axis rotation .....	46
3.4.8	Axis format .....	47
3.4.9	Scale user shade.....	49
3.4.10	Light source.....	52

3.4.11	Symbol .....	54
3.4.12	2D Line Color .....	55
3.4.13	Font System .....	55
3.4.14	Window size .....	58
3.4.15	Window title .....	58
3.5	Options +? .....	59
3.5.1	Extended widget, Minimal Widget, Extended widget + infobox, Minimal widget + infobox .....	59
3.5.2	Load INI file .....	59
3.5.3	Save INI file .....	59
3.5.4	Information about MIRA .....	60
3.5.5	What's new in MIRA VM xx .....	60
3.5.6	Manual about MIRA .....	60
3.5.7	RSI manual about iTools .....	60
3.6	Plot selection .....	61
3.6.1	Net Surf.....	61
3.6.2	Line Surf.....	61
3.6.3	Illumin. Surf.....	62
3.6.4	User-shad. Net .....	62
3.6.5	User-shad. Lines .....	63
3.6.6	User-shad. Surf.....	63
3.6.7	Illumin. + Net.....	64
3.6.8	Illumin. + Lines .....	64
3.6.9	User-shad. + Net .....	65
3.6.10	User-shad. + Lines .....	65
3.6.11	Image Height .....	66
3.6.12	Interpolated Image Height .....	66
3.6.13	Image User Shade .....	67
3.6.14	Single 2D .....	67
3.6.15	Multiple 3D .....	68
3.6.16	Show3.....	68
3.6.17	Contour.....	69
3.6.18	Image + Cont. ....	69
3.7	Modify.....	71
3.7.1	Linear flatten .....	71
3.7.2	Polynom flatten.....	73
3.7.3	Rolling sphere flatten .....	74
3.7.4	Spike removal.....	75
3.7.5	Advanced Spike Removal .....	78
3.7.6	SECM deblurring/edge enhancement .....	79
3.7.7	Adjust bundle setting.....	80
3.7.8	Edit data.....	83
3.8	Analysis.....	84
3.8.1	Profile.....	84
3.8.2	Evaluate spot array .....	85
3.8.3	Histogram .....	91
3.8.4	1D FFT (Fast Fourier Transformation).....	92
3.8.5	Optimize AD Filter .....	92
3.8.6	Curve fit .....	94

4	Multiplot .....	103
4.1	Elements of Multiplot.....	103
4.2	File.....	105
4.2.1	Add file to list .....	105
4.2.2	Load from IDL binary.....	105
4.2.3	File types .....	105
4.2.4	Change default path.....	105
4.2.5	Selection of graphic format .....	105
4.2.6	Setup of windows printer .....	105
4.2.7	Print .....	105
4.2.8	Start SPM.....	105
4.2.9	Start batch interpreter .....	105
4.2.10	Start Combined Plot.....	107
4.2.11	Start difference plot.....	107
4.2.12	Exit.....	107
4.3	Single plot .....	107
4.3.1	Redraw.....	107
4.3.2	Full path.....	107
4.3.3	Show header .....	108
4.3.4	File.....	108
4.3.5	Data.....	108
4.3.6	Plot format .....	108
4.3.7	Axis/X ~/Y ~/Z .....	109
4.4	Tools .....	109
4.5	Options + ? .....	110
4.5.1	Change layout.....	110
4.5.2	Save layout.....	110
4.5.3	Load INI file .....	110
4.5.4	Save INI file .....	110
4.5.5	Information about MIRA .....	110
4.5.6	What's new in MIRA VM 1.0 .....	110
4.5.7	Manual about MIRA.....	110
4.5.8	RSI Manual about iTools .....	110
4.6	Menu Modify .....	111
4.7	Analysis.....	111
5	Combined Plot.....	111
5.1	Example 1: Creating a combined Surface plots.....	112
5.2	Example 2: Create a Stacked Surface plot .....	113
5.2.1	General background: placing multiple plots on a page.....	113
5.2.2	Use of plot regions for stacked surface .....	114
5.2.3	Fine adjustment of plot regions .....	115
5.2.4	Optimizing a stacked surface plot .....	116
6	Difference Plot .....	118
6.1	Loading Data .....	118
6.2	Exploring and adjusting data sets in Difference Plot .....	119
6.3	Principle of calculation in Difference Plot .....	119
6.4	Exploring results in Difference Plot .....	121
6.4.1	Exploring pair of data sets.....	121
6.4.2	Exploring line scan within one pair of images .....	121

---

6.4.3	Recalculate with a new threshold .....	122
6.5	Use of the Button Calculate difference .....	122
6.6	Exporting the result and handling of the menu in Difference Plot .....	122
6.6.1	File formats for results .....	122
6.6.2	Menu structure in Single Plot .....	122
7	Auxiliary tools .....	124
7.1	MIRA_VM_02_2003.XLS and MIRA_VM_02_2010.XLS.....	124
7.2	Generating a lab book printout with MIRA_VM_02 and MIRA_VM_02_????.xls .....	126

This program is developed for the representation of data from various instruments. The data are processed by unified principles for all data sets, which eases the comparison of data coming from various instruments.

It contains productivity tools that were developed for everyday laboratory routines.

# 1 Installation of MIRA

## 1.1 Preparation of the PC

Software requirements: Windows 2000 or Windows XP, Windows 7, Windows 10 running in 24 bit color depth or 256 bit color depth. There are versions for 32 and 64 bit systems.

It is highly recommended to adjust the regional settings to have the dot "." as the decimal sign and the comma "," as grouping sign of digits within large numbers. This settings corresponds to the standard English number system. Other regional settings can remain on the preferred setting for the country in which the program is used. In order to make the setting (for Windows 7), Start/System settings/Time, Language Region/Region and Language/Date, time and number formats/More settings (Fig. 1)

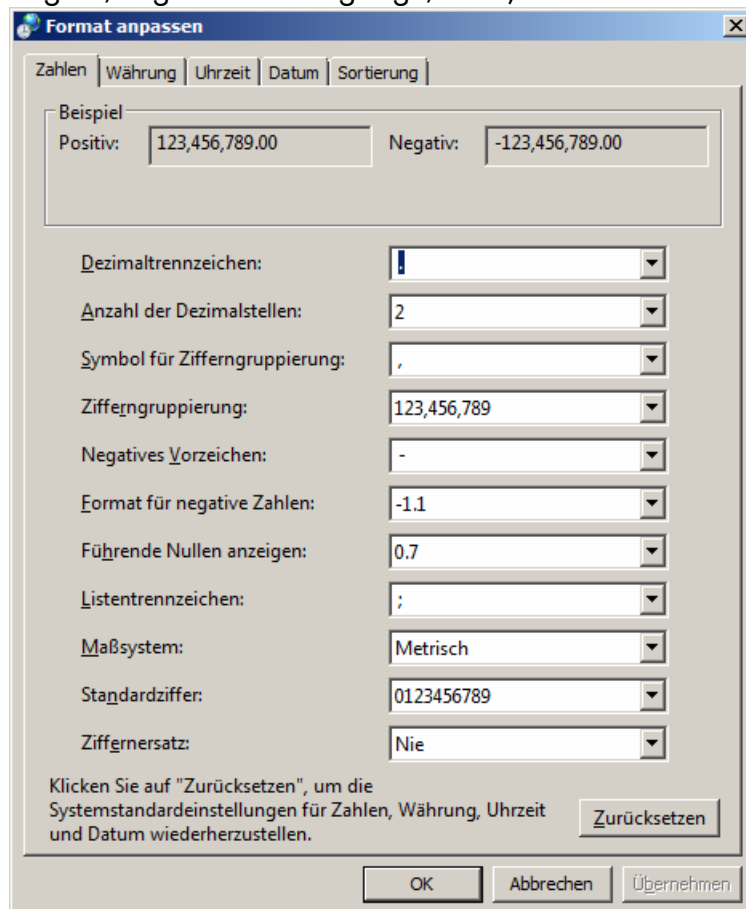

Fig. 1: Recommended settings for number formats.

## 1.2 How to install MIRA

Start the program

**InstallMIRA\_32bit\*.exe**

**InstallMIRA\_64bit\*.exe**

which you find on the CD or which you obtained via internet. If your computer allows autorun, the program will be started automatically, if you insert the CD. The following screen appears.

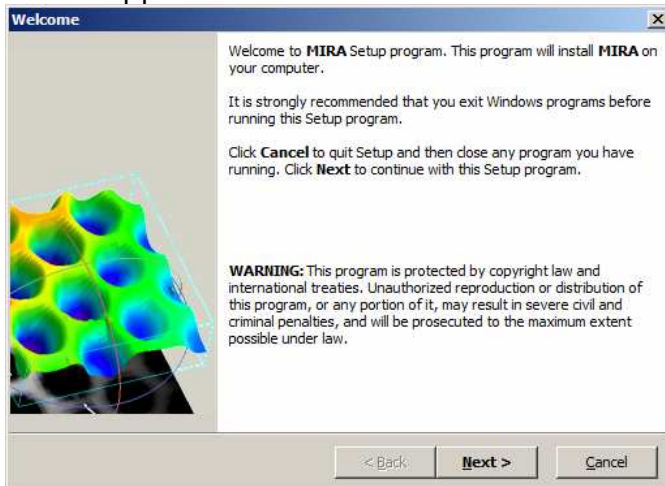

Fig. 2: Screen shot of the MIRA installation program.

In order to run the installation program, you need Administrator rights on the computer.

After continuing with **<Next>** you will be asked for the User Information. Please type the Serial Number exactly as received from the supplier. Press **<Next>**.

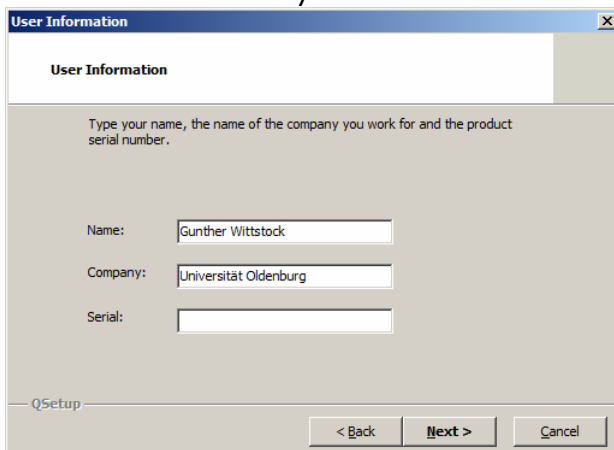

Fig. 3: Dialog for requesting user information.

You are then asked for the folder into which MIRA will be installed. In contrast to previous versions, [this installation does not require a previous installation of IDL Runtime](#). You are independent of any change in the IDL language. You do not need to contact Research Systems.

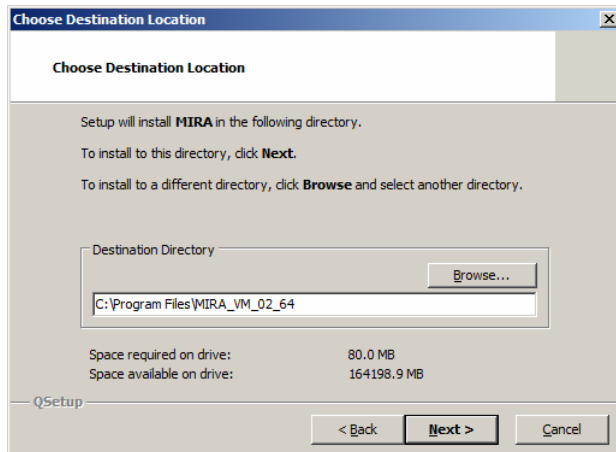

Fig. 4: Dialog for requesting installation path.

The installer will create shortcuts on the desktop and entries into the Quick Launch bar for all users. You can modify the entries.

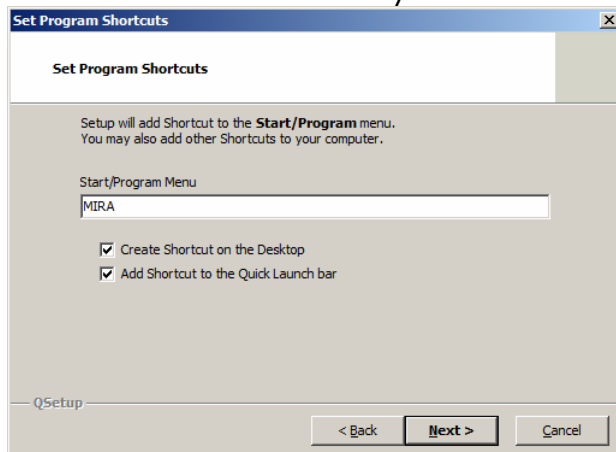

Fig. 5: Dialog for confirming entries in Start/Program menu, desktop icon and Quick Launch bar.

The installer then copies all files to the new application folder. The following directory structure is created.



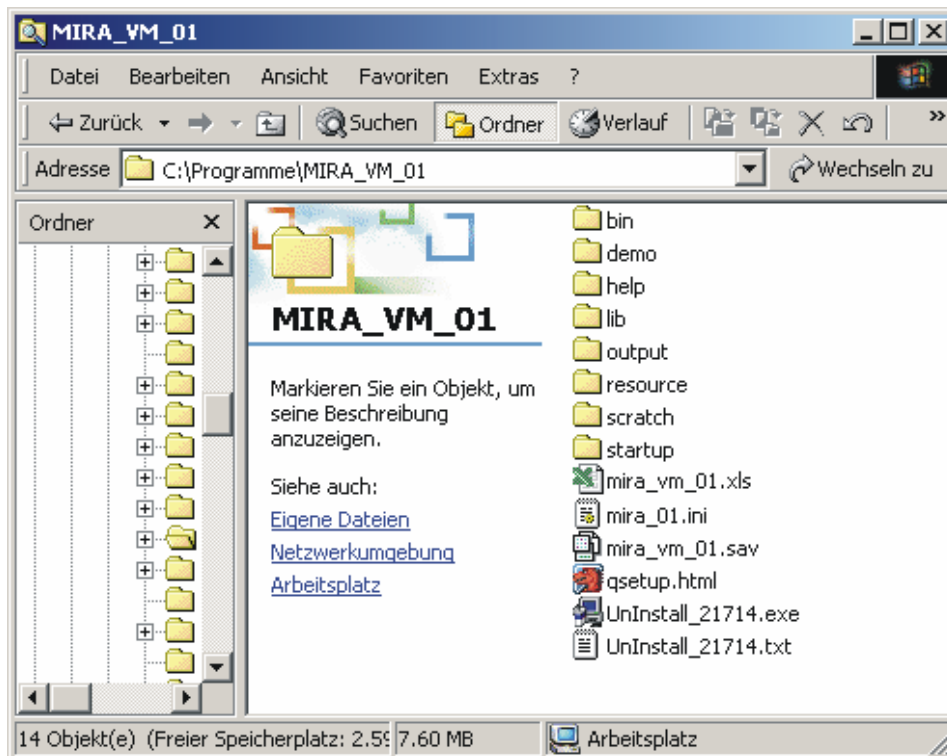

Fig. 6: Directory structure of the MIRA VM installation.

Three files will be copied to the `~\winnt\system32` folder:

`mfc70.dll`

`msvc70.dll`

`msvcr70.dll`

if the DLL is newer than any possible DLL of the same name already in the folder

After completing copying all files, the program should be started from the following screen.

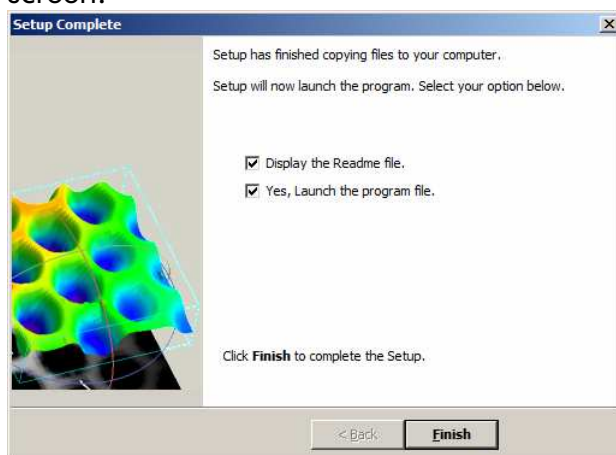

Fig. 7: Dialog for starting MIRA for the first time.

It is necessary that MIRA is started now, because information is transferred from ini-files to the registry entries on the machine. Please confirm the following query (Fig. 8). It might be that this dialog appears *behind* other windows. In such case move other windows away to find the file. After that, the installation process is completed. From now on MIRA should start as described in the next chapter.

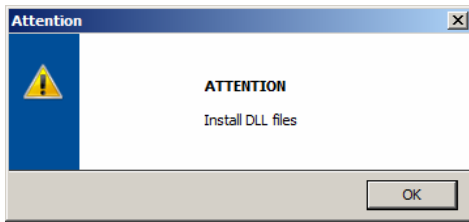

Fig. 8: Dialog for importing preferences, press <Ok>.

**NOTE:** We have observed that the installation occurs incomplete on some settings under Windows 7. In this case, please, start the following files manually by starting them from the Windows Explorer:

32-bit Windows version    [Installation\_Path\bin\bin.x86\systemdll32\_setup.exe  
 64-bit Windows version    [Installation\_Path\bin\bin.x86\systemdll64\_setup.exe

Continue then as described in Section 2.1

### 1.3 How to uninstall MIRA

Start *Uninstall MIRA* from the *Start/Program/Mira* group. All files will be removed, EXCEPT: *mfc70.dll*, *msvcp70.dll*, *msvcr70.dll* because they might be used by another program. Also the path *~\output* will not be removed if it contains user data. If it is empty, it will be removed.

## 2 First look at MIRA

### 2.1 Launch MIRA

Right after the installation MIRA should start automatically if the settings of Fig. 7 were confirmed. Later, you can start MIRA by a double click on the icon on the desktop and

The following window appears, click on "mira\_vm\_02" and then on "Click to Continue" to proceed. The program is based on IDL (Interactive Data Language, vers. 8.1 by Research Systems Inc., Boulder Colorado)



Fig. 9: Startup window of the IDL data processing machine.

A window as in Fig. 10 opens and you can select between two startup configurations: *Multiplot* and *Single Plot* and various *<.ini>*-files that contain user-specific preferences.

*Multiplot* means that you can load many data sets into one form. Processing can be toggled quickly between these data. The configuration *Single Plot* stands for the opposite: Only one data set is processed.

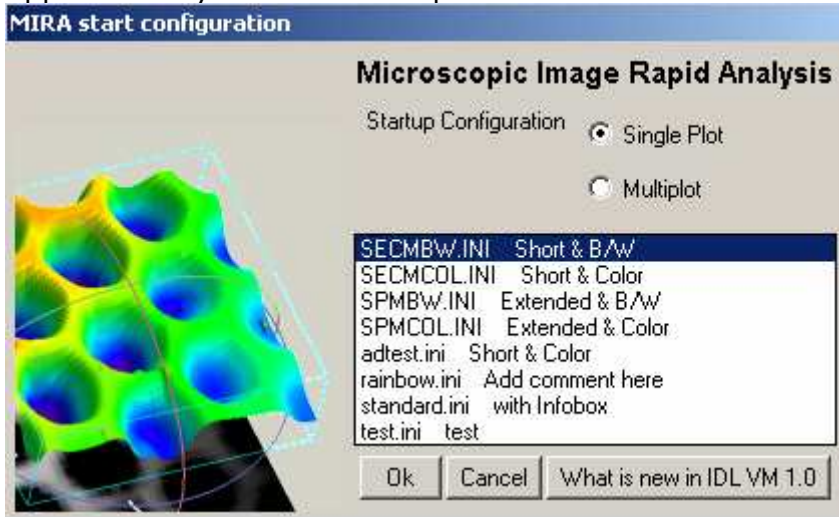

Fig. 10: Select Startup Configuration

These two versions can be started with a number of user-defined startup settings. They are stored and can be retrieved from *<\*.ini>* files. Among others the startup values determine the appearance of the first window. A standard initialization is given. Other startup values can be created by saving current settings. A startup file is given below. It can of course also be edited by a text editor. After choosing the configuration and the default value you can start with **<Ok>**. Alternatively you can double click on an *<\*.ini>* files to start the application.

[MIRA USER DEFAULTS]	Section header
FOLLOWING LINES = 12	Number of the following lines
COMMENT = Standard	Comment which is shown in the menu selection
INFOBOX = True	If true displays in the Single Plot and Multiplot windows a status bar.
LAYOUT = EXTENDED	Type of layout. The program differs between extended and minimal widget. → <i>Single Plot</i>
COLORTABLE = 39	There is a selection of 40 predefined color tables (0–39)
SHADE TOP = 254	Color shade scale from 0 till 254 That means that there are 255 different shades. The upper bound is modifiable. From the index 255 is the color used for axis or labels.
STANDARD 3D PLOT = Image	Standard graphic mode for 3D datasets
STANDARD 2D PLOT = Single 2D	Standard mode for 2D datasets
STANDARD MULTI-2D PLOT = Multiple 2D	Standard mode for multiple 2D datasets
STANDARD DATA INPUT PATH = D:\Dateien\Mira\Input	Standard path where data were read out off.
STANDARD OUTPUT PATH = D:\Dateien\Mira\Output\	Standard path for print files.
STANDARD FORMAT FILE PATH = D:\Dateien\Mira\SPM\	Standard path for formatting files.
STANDARD PRINTER = Color encapsulated PS	Standard graphic format

## 2.2 Customizing MIRA

After installation the data input path is the path with demo data supplied with the installation. The output path is an empty folder within the application folder. It is strongly recommended that each user of the machine makes its input and output path OUTSIDE the MIRA application path and save the preferences to an ini-file such as *gunther.ini*, *felix.ini* and *alena.ini*. We made good experiences with an arrangement, where each user has an own data input path and a data output path. **It is strongly recommended that data output path is NEVER the same as the data input path.** Otherwise, there is a risk that input data are overwritten although MIRA will query before doing so (new in this version). Interruptions by queries will not be a problem if the output path is used exclusively to receive output from MIRA.

You can change the path setting (and others) by starting the menu *Options + ?/Save INI file*. Use the **<Select>** button besides the text fields to select a new path in your folder tree. After selecting all options, confirm with **<Ok>** and select a file name for the ini file. You must specify the extension *.ini*. Otherwise the file will not be found upon startup.

In order to make the ini file your current preference, load it with *Options + ?/Load INI file*.

For a more detailed description see the description of the menu *Option + ?/Save INI file.*



Abb. 11: Dialog for making user-specific initializations. The input path and the output path should be changed for each user.

### 3 Single Plot

This configuration can be used with two settings: *Extended widget* and *Minimal widget* and Info box True/False.

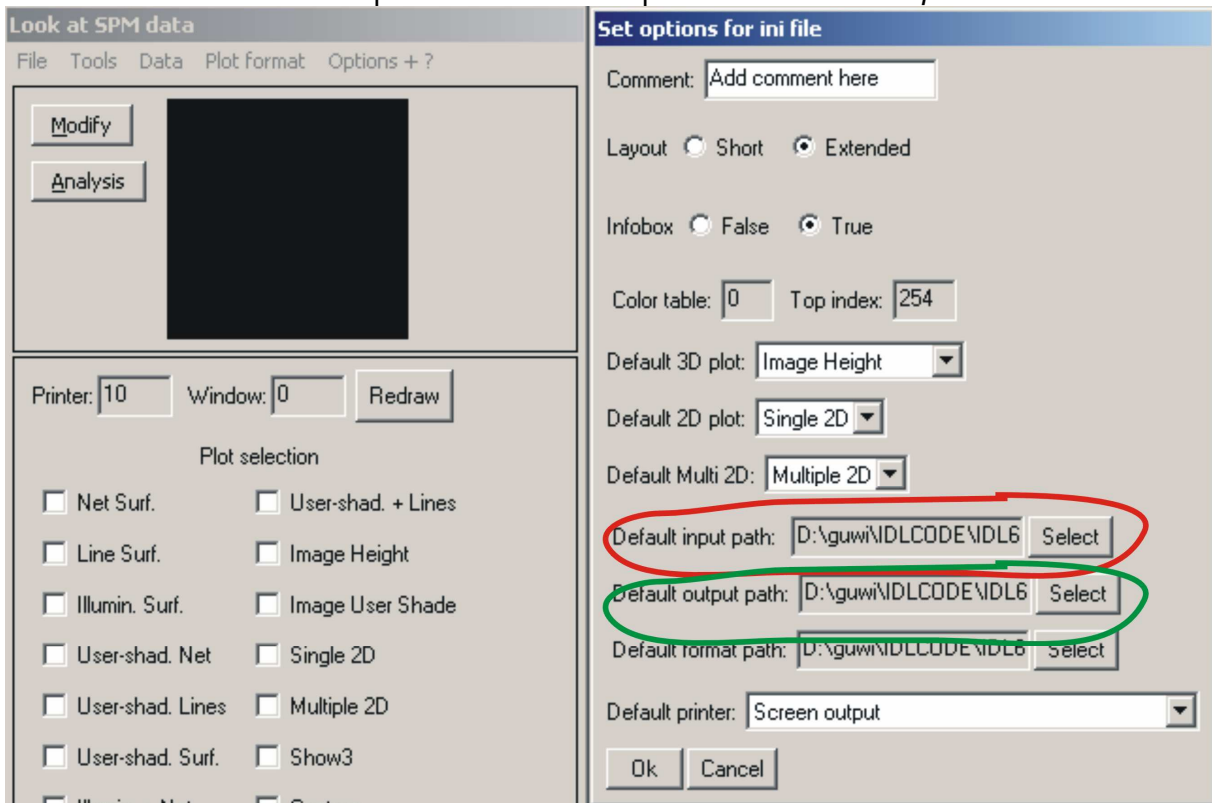
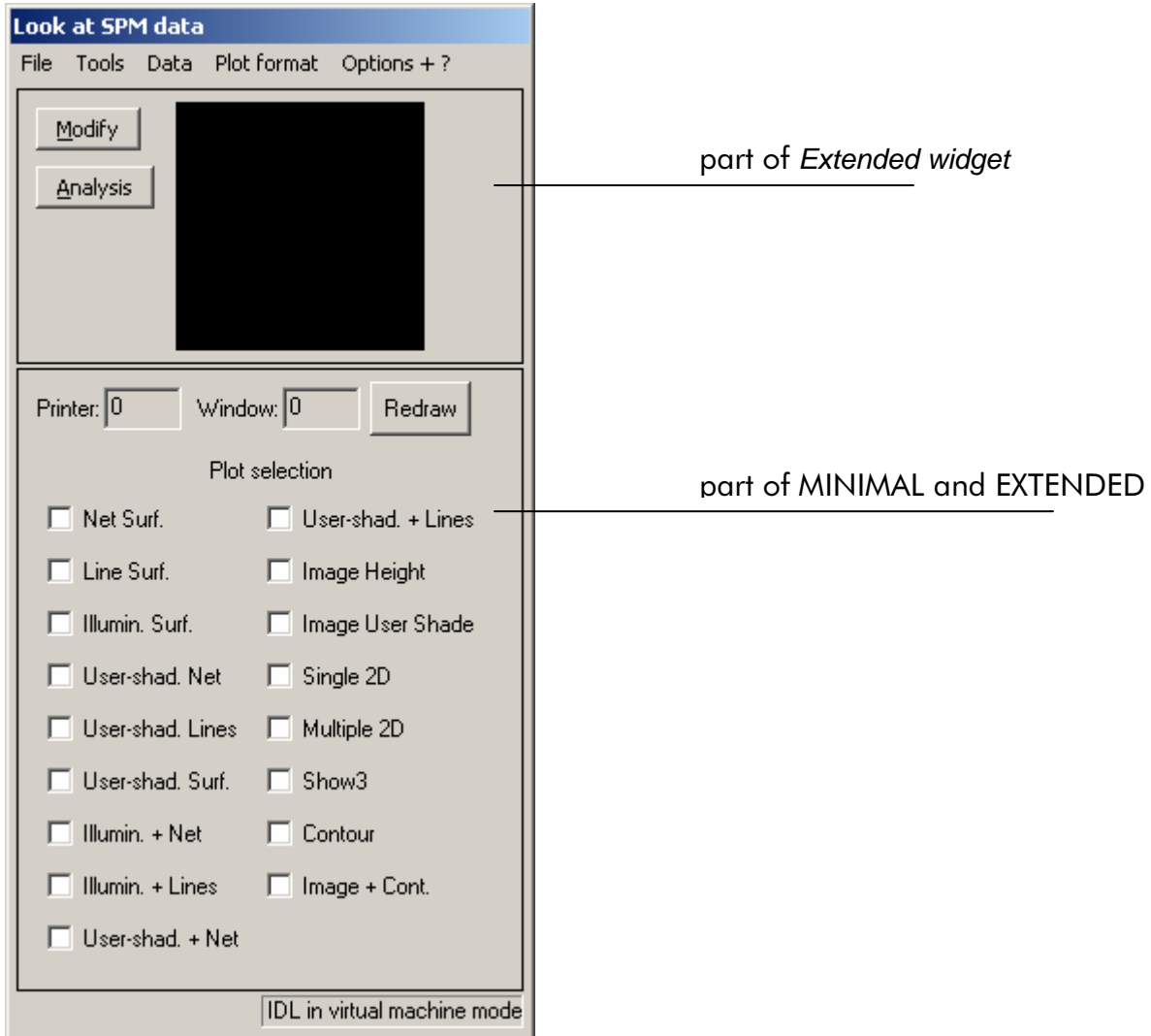

Fig. 12: Extended Widget

As you can see at Fig. 12 *Extended* means that a preview of the marked plot is included in the widget. If your screen is small a minimal widget might be more practical as you can see the entire form. Choose *Options* to select a display mode.

This preference can be saved in *<name.ini>*.

In the following section the menu items are explained.

## 3.1 File

### 3.1.1 Open File

An existing file can be opened. Every file type, MIRA has an import filter for is detected automatically. If the program does not detect your file type, please get in touch with [Gunther.Wittstock@Uni-Oldenburg.de](mailto:Gunther.Wittstock@Uni-Oldenburg.de)

Till now files of the following commercial apparatuses are recognized:

AUTOLAB	potentiostat
CHI	potentiostat
DME	scanning probe microscope
NANOSCOPE	scanning probe microscope
VG	electron microscope
MOLECULAR IMAGING	scanning probe microscope

and diverse home-built apparatuses of several groups

If the inner structure of the files is known, other import filter for other instruments can be made on demand.

### 3.1.2 Change default paths

You can choose the defaults path for Data input Graphic output and formatting input/output. Please note that when loading files, the input path for this loading procedure can be changed in a dialog. However, for data safety input and output path should never be identical. To change the path setting click on select and use the standard path navigator dialog to select a path.

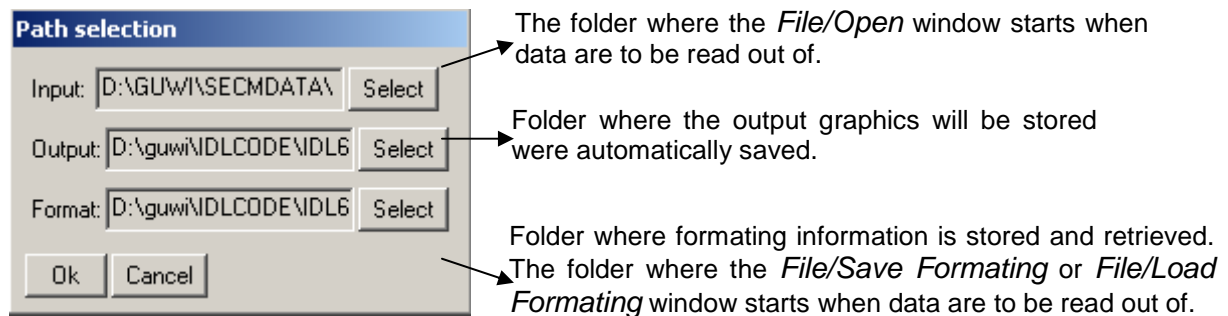

Fig. 13: Path Selection

### 3.1.3 Save/Load formatting

Select a file to save the formatting information in it. This menu should be chosen if your file is finished and you only want to archive the result. Further MIRA versions will read the file without any problems if the basic structure of MIRA is still unchanged.

Further you can load an existing formatting file to be applied to the data (*Load as current hardware setup*) or to define a new standard for subsequent data sets (*Load as session default*).

Press select to choose a file of which you want to load the information. Finish your selection by pressing **<OK>**. Up to this moment it is also possible to cancel loading.

### 3.1.4 Save to/Load from IDL (Interactive Data Language) binary

IDL is a commercial array-oriented language with numerical analysis and display features. It supports interactive reduction, analysis, and visualization of scientific data. Save a file together with the formatting information in a compressed file format. It allows to save the working state including the processing, axis formatting etc. for later reprocessing. **WARNING:** Old *IDL* binary file might be not readable in future *MIRA* versions. This option should be used only for short term storage of work in progress. For long-term archiving saving the original data together with a record on all operation performed with *MIRA* is suited best.

### 3.1.5 Import form ASCII

ASCII file can be imported into IDL. They must have on out of three formats. Empty lines are ignored. Comments can be present if preceded by a comment identifier character sequence.

Format type 1: columns of equal length for x,y,z as used by Origin etc.). There can be 2 or 3 columns.

X <sub>0</sub>	Y <sub>0</sub>
X <sub>1</sub>	Y <sub>1</sub>
X <sub>2</sub>	Y <sub>2</sub>
...	...
X <sub>n</sub>	Y <sub>n</sub>

X <sub>0</sub>	Y <sub>0</sub>	Z <sub>0,0</sub>
X <sub>1</sub>	Y <sub>0</sub>	Z <sub>1,0</sub>
X <sub>2</sub>	Y <sub>0</sub>	Z <sub>2,0</sub>
...	...	...
X <sub>0</sub>	Y <sub>1</sub>	Z <sub>0,1</sub>
X <sub>1</sub>	Y <sub>1</sub>	Z <sub>1,1</sub>
...	...	...
X <sub>0</sub>	Y <sub>n</sub>	Z <sub>0,n</sub>
...	...	...
X <sub>m</sub>	Y <sub>n</sub>	Z <sub>n,m</sub>

Format type 2: A matrix with x and y values surrounding the z values

--	Y <sub>0</sub>	Y <sub>1</sub>	Y <sub>2</sub>	...	Y <sub>n</sub>
X <sub>0</sub>	Z <sub>0,0</sub>	Z <sub>0,1</sub>	Z <sub>0,2</sub>	...	Z <sub>0,0</sub>
X <sub>1</sub>	Z <sub>1,0</sub>	Z <sub>1,1</sub>	Z <sub>1,2</sub>	...	Z <sub>1,0</sub>
X <sub>2</sub>	Z <sub>2,0</sub>	Z <sub>2,1</sub>	Z <sub>2,2</sub>	...	Z <sub>2,0</sub>
...	...	...	...	...	...
X <sub>m</sub>	Z <sub>n,0</sub>	Z <sub>n,1</sub>	Z <sub>n,2</sub>	...	Z <sub>n,0</sub>

Format type 3: A matrix with only z values. x and y values will be integers numbering the columns and rows. The can be transformed to real values using *Data/Arithmetics/X-axis* or *~/Y-Axis*.

Z <sub>0,0</sub>	Z <sub>0,1</sub>	Z <sub>0,2</sub>	...	Z <sub>0,0</sub>
Z <sub>1,0</sub>	Z <sub>1,1</sub>	Z <sub>1,2</sub>	...	Z <sub>1,0</sub>
Z <sub>2,0</sub>	Z <sub>2,1</sub>	Z <sub>2,2</sub>	...	Z <sub>2,0</sub>
...	...	...	...	...
Z <sub>n,0</sub>	Z <sub>n,1</sub>	Z <sub>n,2</sub>	...	Z <sub>n,0</sub>

After selecting the menu item the following window appear.



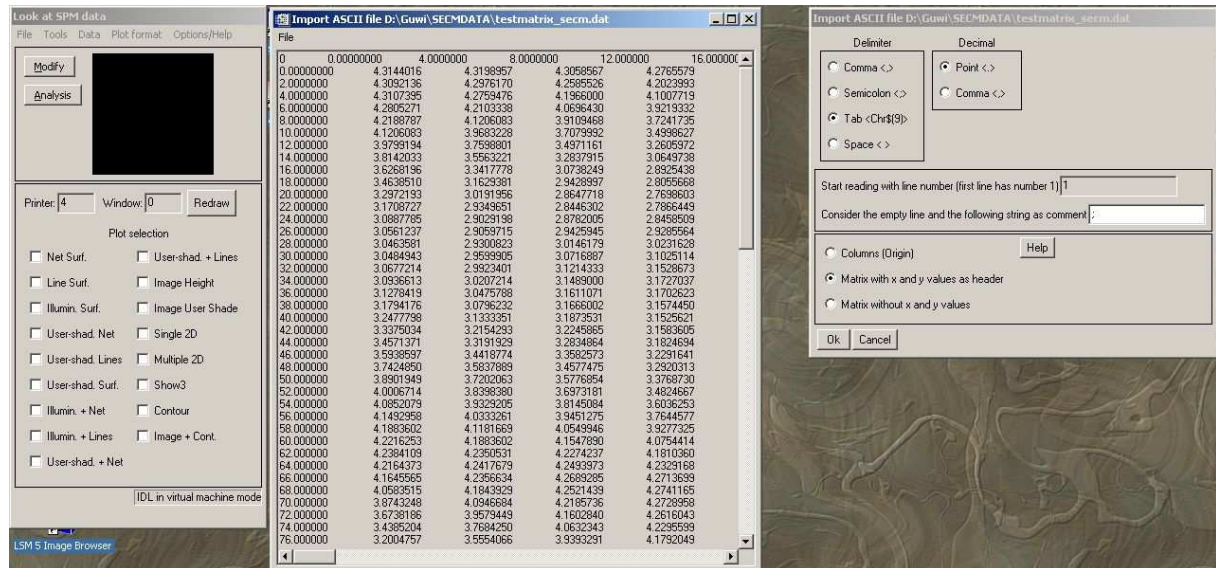

Fig. 14: Windows for importing ASCII data. The file is displayed (middle) to help setting the proper option in the right window.

The options regarding delimiter, decimal point and data arrangements can be adjusted according to the displayed file in the middle. You can specify one or more characters that identify a line within the file as a comment. The content of comments will not be read into variables. Many data files contain header, start marks etc. that can be skipped in this way. A specified numbers of lines can be treated as header. If an error occurs during reading the routine should exit quietly.

### 3.1.6 Export to ASCII

Export the present file to the *ASCII* format. Various options are available to make the exported file processable by spread sheet programs like *EXCEL™* and *ORIGIN™*. ASCII is a standard character set, which transfers every information to an eight-bit character. This code is readable for nearly every computer.



Fig. 15: Export To ASCII

Figure 15 shows the different options of presentation the numerical order of and between the codes.

### 3.1.7 Selection of graphic format

There are different kinds of graphic output options:

<b>Screen output</b>	Choosing screen output you will get a printout of the complete screen.
<b>Draw widget</b>	Graphic setting for little windows inside the MIRA program
<b>B/W encapsulated PS</b>	PostScript commands do not drive the printer directly. They are language statements in ASCII text that are translated into the printer's machine language by a PostScript interpreter built into the printer. Encapsulated PostScript (EPS) is a subset of PostScript used to exchange a single graphic image in the PostScript format.
<b>Color encapsulated PS</b>	→ <i>B/W encapsulated PS</i>
<b>TIFF</b>	Tagged Image File Format A widely used bitmapped graphics file format that handles monochrome, grey scale, 8-and 24-bit colour. The particular settings are optimized for producing a graphic with 600 dpi when printed on a 8.75 cm wide column used in many scientific journals. You may change the default settings for customizing the size and appearance.
<b>TIFF for PPT presentation</b>	Tagged Image File Format (see above) The particular settings are optimized for producing a graphic that fits approximately on one half of a standard PowerPoint presentation without requiring too much memory and loading time. You may change the default settings for customizing the size and appearance.
<b>JPEG</b>	Joint Photographic Experts Group. Compressed files with acceptable quality. The quality is good for shaded images. It is often unacceptable for line drawings. Many journals will not accept this file type for high quality graphs
<b>Windows system printer</b>	Currently selected standard printer.

On the right sight of the window you can adapt the output format of the selected printer.

Default values of all parameters are stored separately for 2D graphs and surface plots because the appearance of labelling is different.

<b>Left margin contribution</b>	The margin is composed of two contributions: The plot type and the type of output file. Here you can change the output file contribution for the left margin. For plot type depending margin look at <i>Plot format/Plot-dep, margin</i> .
<b>Right margin contribution</b>	→ <i>Left margin contribution</i>
<b>Bottom margin contribution</b>	→ <i>Left margin contribution</i>
<b>Top margin contribution</b>	→ <i>Left margin contribution</i>
<b>Horizontal size</b>	Change the horizontal size of the graphic. The number of pixels is given.
<b>Vertical size</b>	Change the horizontal size.
<b>Character size factor</b>	Choose a dimensionless factor for the size of the graphic.
<b>Character thickness factor</b>	To change the thickness of the labelling of the axis enter the favored factor. To change only the character thickness of one of the axis → <i>Plot format/Axis format</i>
<b>Line thickness factor</b>	Choose a dimensionless factor for the line thickness.
<b>Tick length ratio</b>	According to the parallel axis percentage tick length of another axis can be selected.
<b>Foreground color</b>	Change the color of the axis and the labels. To get the information about the color-number-affiliations look at <i>Tools/XPalette</i> .
<b>Background color</b>	Choose a color for the background. Depending on the printer a start up value is given. Changing the color might be important if your graphic contents a similar palette of colors than the background.

If you are not pleased with your selection you can go back to the startup values.

Note: The appearance of margins may vary between screen output and different graphic formats. There are two contribution to the margin: one contribution depending on the output format (Screen, eps, tif, ...) and one depending on the plot type (surface, image, 2D line graph). Here adjustment should be made to bring the appearance on different output formats in rough agreement. Sometimes graphs require a change of the margins (e.g. if the tick labels at the vertical axis have different numbers of significant digits ("1.5" vs. "1.558"). This would affect all possible output formats and therefore the change should be made under *Plot format/Plot-dep* (section 3.1.7).

### 3.1.8 System printer setup

Choose an installed printer for your printout. If it is necessary change the features by pressing the button. Selecting here a printer for making PDF files is the preferred way of generating PDF output.

### 3.1.9 Print

Click on print to print out the present graphic. **Caution:** a name will be automatically generated and **without query** the file will be printed. If you want to print several versions of one data set in a graphic format, they will overwrite each other and you will find only the file from the last print command. Rename the files after printing to prevent this effect. This algorithm was introduced to accelerate routine processes and avoid annoying queries by the computer.

### 3.1.10 Start MULTIPLT

If you want to change from *Single plot* to *Multiplot*, you can do that without starting the program once again. The appearing window is shown in figure 16.

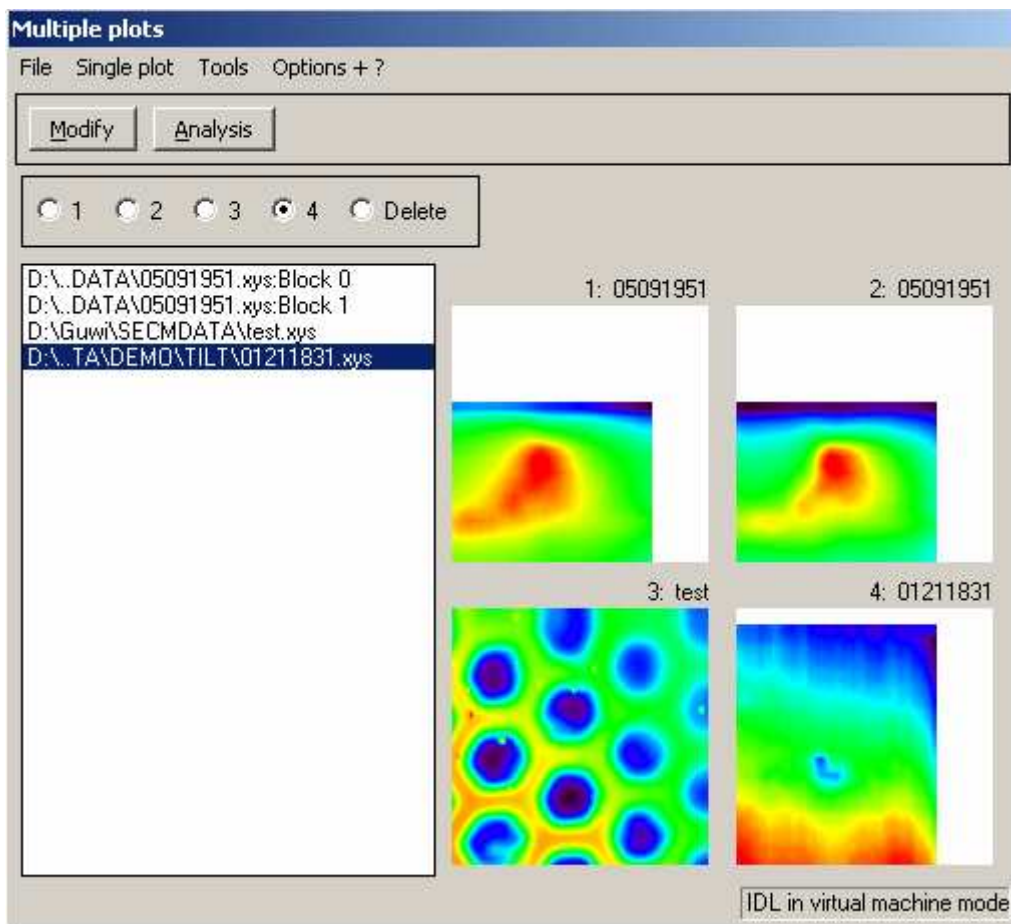

Fig.16: Multiplot Main Window.

→ *Multiplot*

### 3.1.11 Add to MULTIPLT

Add a the currently processed data set from *Single Plot* to the file list in *Multiplot*. That file will be written down in the list in the left part of the window. How to work with *Multiplot* → *Multiplot*

### 3.1.12 Exit

Click on *File/Exit* to finish the program.

Note: Do not exit MIRA while iTools are still active. First close iTools then close MIRA.

## 3.2 Tools

### 3.2.1 XLoadct

Choose a color palette out of forty predefined color tables. To change the brightness it is possible to vary the top and the bottom of color shade (Fig 17).

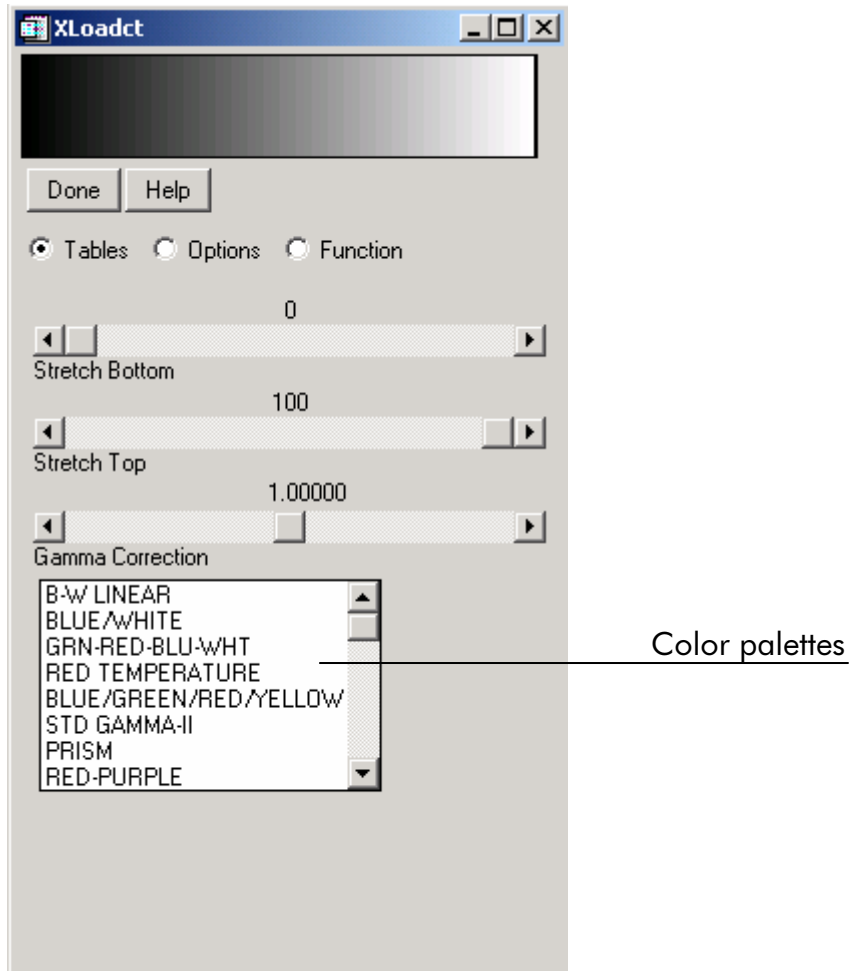

Fig. 17: Xloadct, main screen.

### 3.2.2 XPalette

For editing the palette a separate tool XPalette is available. Figure 18 shows the main screen of the palette of functions.

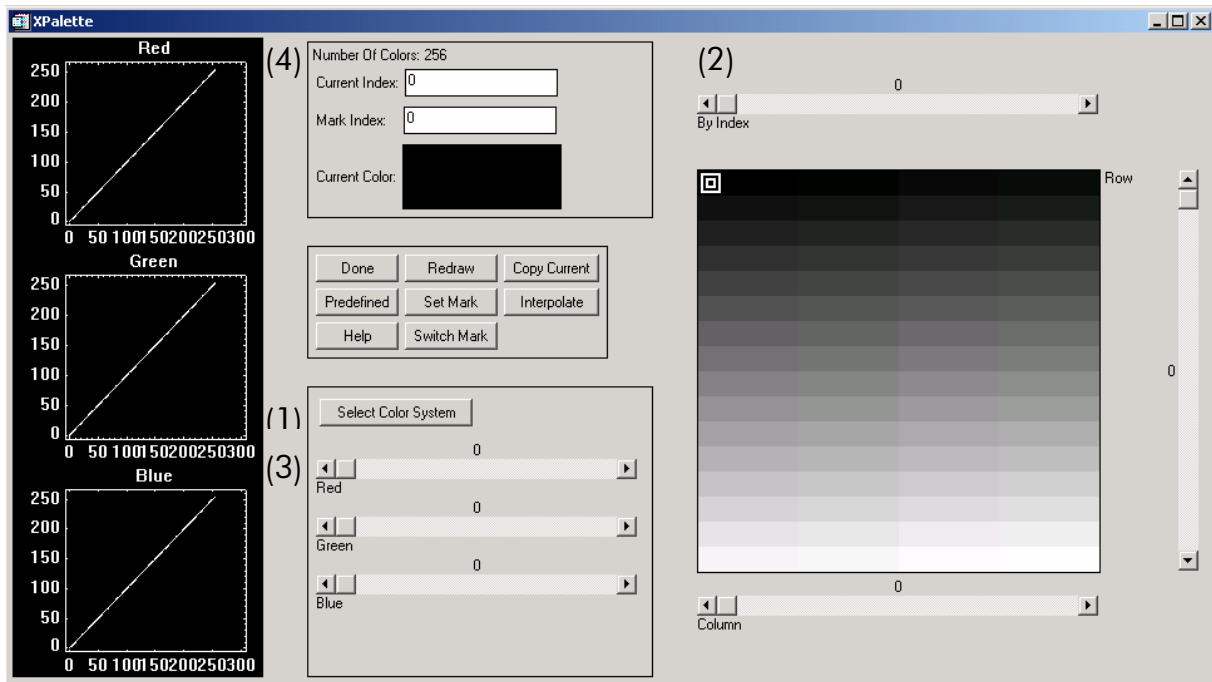

Fig. 18: XPalette, main screen.

At first you should select a color system (1) with which you want to work.

- RGB (Red/Green/Blue)
- CMY (Cyan/Magenta/Yellow)
- HSV (Hue/Saturation/Value)
- HLS (Hue/Lightness/Saturation)

By marking a field (2) you can vary the ratio of the different colors (3). To find a special number of one of the 256 colors it is also possible to write down (4). The three diagrams on the left show the amount of red green and blue for each color index.

There are some supporting and executive options in the middle of the window:

**Done**

Press **<Done>** if you want to close the window. All changing will be saved for the following applications.

**Redraw**

After every changing you have to press **<Redraw>** in order to verify.

**Copy Current**

If you want to get the same color for a row of fields mark the first field of which should assume the color specified by Set Mark. View the result by with **<Redraw>**.

**Predefined**

*Predefined* allows to change the color palette. The window *XLoadct* will appear. After your selection press **<Done>** to go back to *XPalette*. To view the change press **<Redraw>**.

**Set Mark**

Press this button to give the border for one of the functions *copy current*, *interpolate* or *switch mark*.

**Interpolate**

To interpolate a color shade between to borders you at first have to mark one border and press **<Set mark>**. After making the other border press **<Interpolate>** and verify with **<Redraw>**. The result will be a smoothed transition from one color to the other.

## Help

To get some help by the program press **<Help>**.

## Switch Mark

If you have worked with *Copy Current* and you want to take the color for the row not from the first marked but from the second marked field press **<Switch Mark>** after marking once again the border. So the number of color gets interchanged between *Current Index* and the *Mark Index*. To verify this process press **<Redraw>**.

### 3.2.3 Show header

Here you will find the measuring conditions registered by the measure device.

For example, a simple *Show header* form is shown in Figure 19.

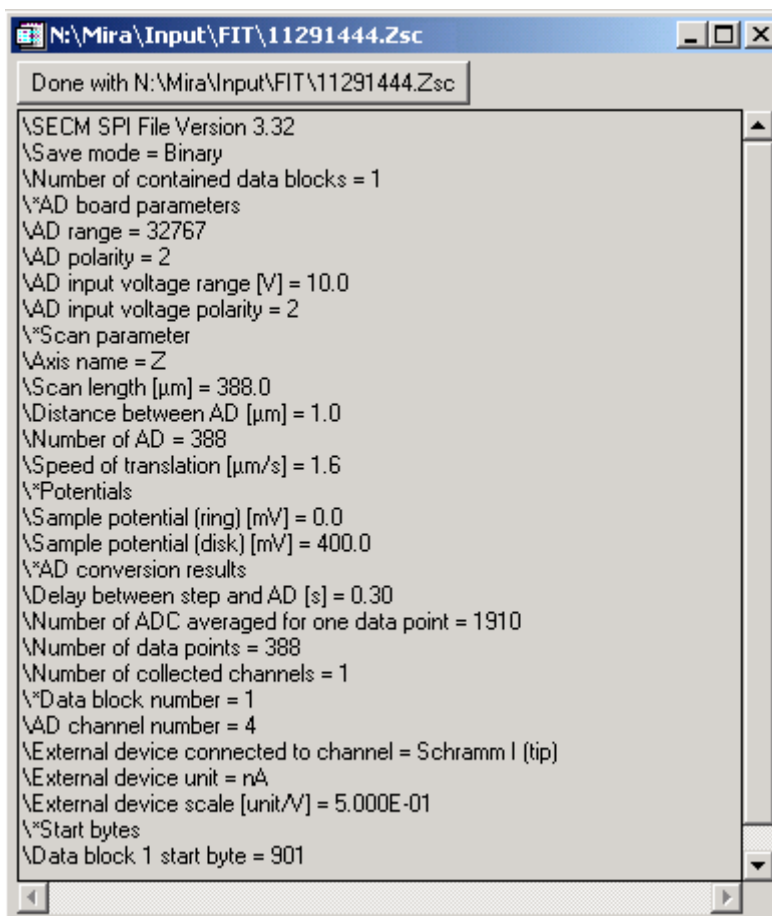

```

Done with N:\Mira\Input\FIT\11291444.Zsc
\SECM SPI File Version 3.32
\Save mode = Binary
\Number of contained data blocks = 1
\*AD board parameters
\AD range = 32767
\AD polarity = 2
\AD input voltage range [V] = 10.0
\AD input voltage polarity = 2
\*Scan parameter
\Axis name = Z
\Scan length [µm] = 388.0
\Distance between AD [µm] = 1.0
\Number of AD = 388
\Speed of translation [µm/s] = 1.6
\*Potentials
\Sample potential (ring) [mV] = 0.0
\Sample potential (disk) [mV] = 400.0
\*AD conversion results
\Delay between step and AD [s] = 0.30
\Number of ADC averaged for one data point = 1910
\Number of data points = 388
\Number of collected channels = 1
\*Data block number = 1
\AD channel number = 4
\External device connected to channel = Schramm I (tip)
\External device unit = nA
\External device scale [unit/V] = 5.000E-01
\*Start bytes
\Data block 1 start byte = 901
  
```

Fig. 19: Example of a header.

### 3.2.4 iSurface

Starting with this version of MIRA, access is provided to the iTools coming from RSI. This is a family of user interface tools that is programmed by RSI. It shall indicate the future development of the IDL language. It uses an object-oriented approach to graphics whereas MIRA in its traditional form provides direct graphics. In short direct graphics seems to be more efficient for repeating graph applications like encountered in SPM applications. iTools add more to flexibility. However, they are not nearly as efficient for preparing graphs for a lot of measurements obtained on one day. The author recommends to use direct graphics of MIRA for creating plots for notebooks and to use iTools only for those tasks where MIRA does not offer a function. Examples are changing font types and combining different data sets in one graph, making

transparent surface plots etc. iTools come with an own set of import and export options. A complete description how to use iTools is beyond the scope of this manual. There is an own manual by RSI which you can call from *Option/Help/RSI Manual about iTools*. Here the general functionality is explained and the data transfer to MIRA is explained. This is the same for all iTools and will not be repeated with the other iTools. If iTools are called with no data sets loaded an empty iTools will be created. You may use that to import some standard data formats supported by RSI. Data formats of specialized instrumentation that are automatically recognized by MIRA will not be loaded.

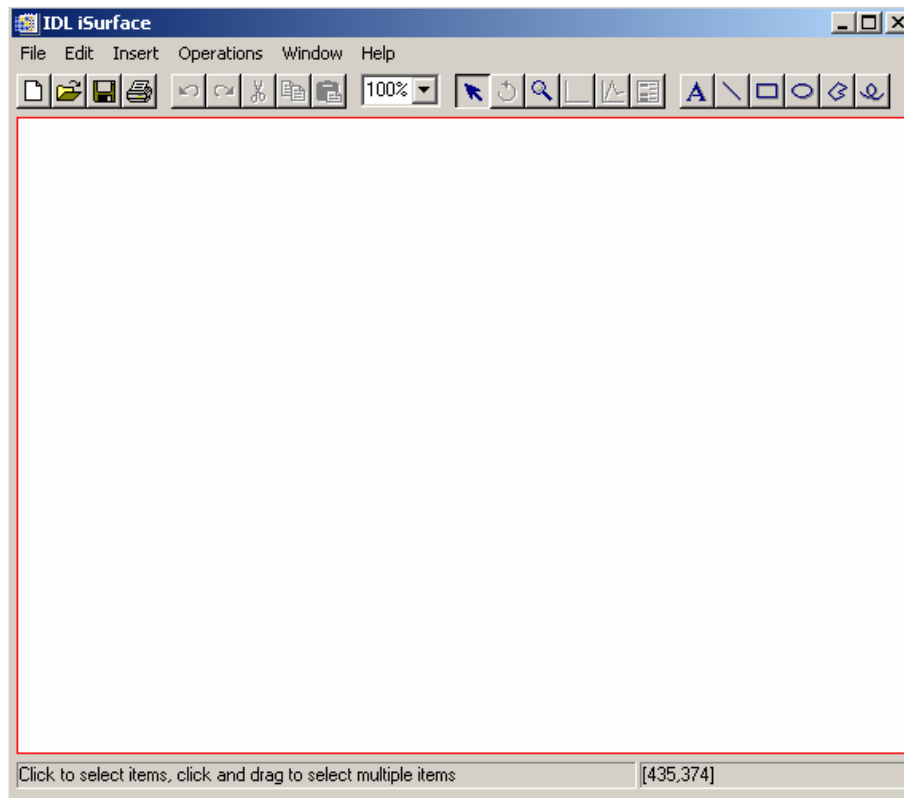

Fig. 20: Empty iSurface tool.

If a 3D data set is loaded, iSurface, iContour, ilmage are started with this data set.



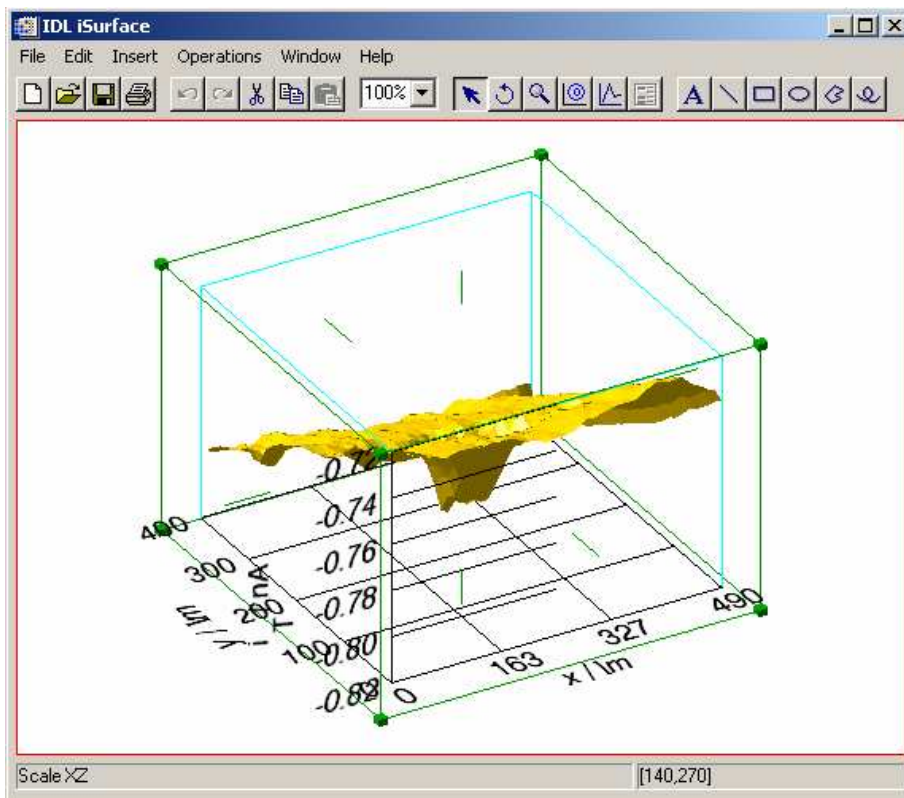

Fig. 21: ISurface with data set.

Changes to the appearance of the plot are made by clicking on the object (e.g. an axis), pressing the right mouse button and calling *Properties*.

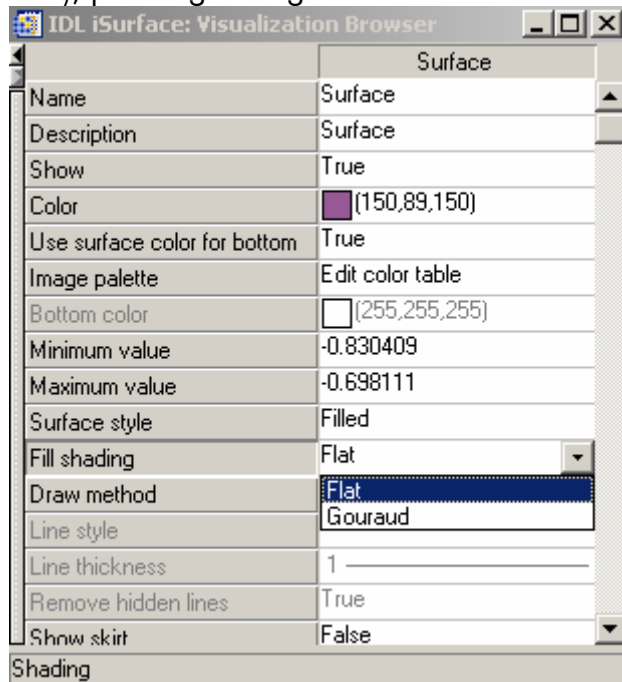

Fig. 22: iSurface property sheet for controlling the properties of the shaded surface. To get the quality you are used to from MIRA you have to set *Fill shading* on Gouraud.

One of the potential application of iTools is the creation of combined plots of two images, e.g. from combined topographic and reactivity imaging from SECM and AFM. Load first the topography data into the *Single Plot* (it works for *Multiplot* the same way). Start iSurface. The data are transferred to the iTool Data manager. Now load the

reactivity data. Start iSurface again. You get a second iSurface window with the current data sets. The data do NOT overwrite each other in the iTools. Now you select *Insert/Visualization* in the iTools. You can select a data set (topography) to be plotted as surface and another for the Texture (that is the shading). The export of data from iTools back to MIRA is possible only via Exporting a file from the iTools and reading that into MIRA. This feature has not been tested. It is expected that iTools will develop very fast. Further updates and bug corrections depends on the availability of new IDL versions to the developer of MIRA. No promise can be made at this points. The author would welcome your wish list without returning a warranty that all wishes can be realized.

In general, in the status line at the button of the iTools, the selected object is shown and the possible operations are explained.

### 3.2.5 iSurface (Shaded)

For a description see iSurface above.

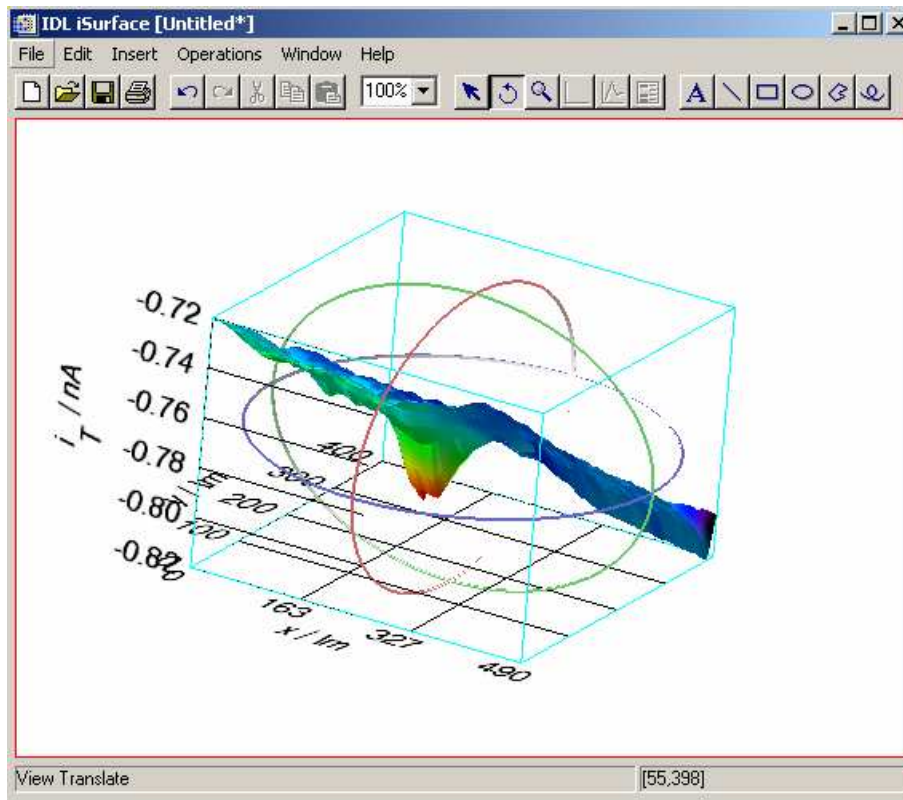
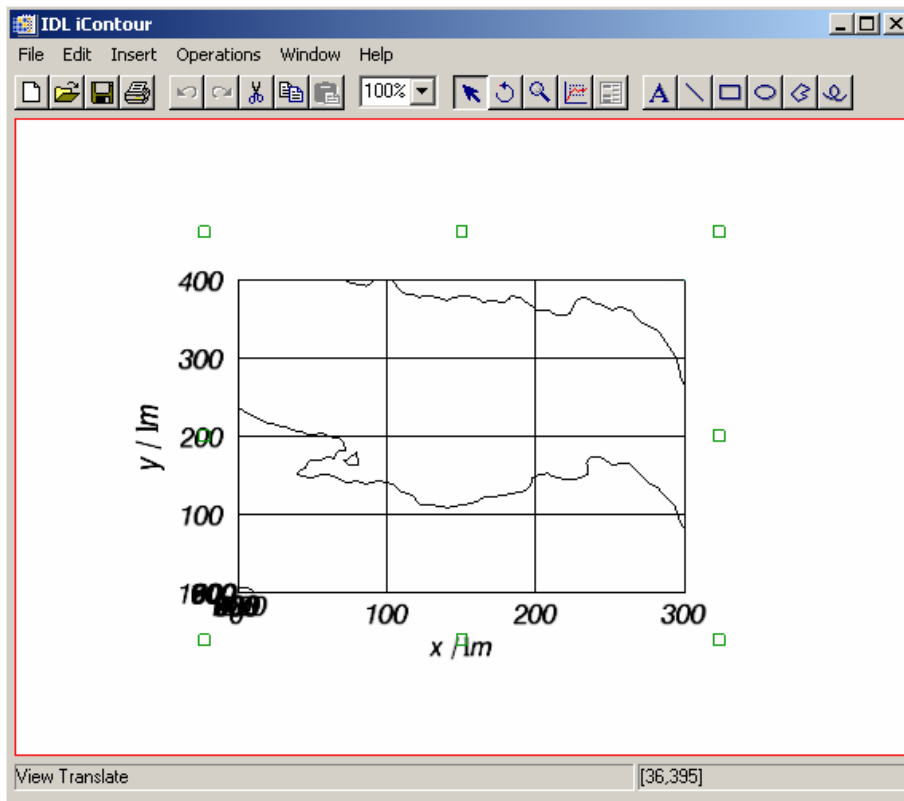

Fig. 23: This is a *iSurface (Shaded)* plot with the rotation tools in action. To get a smooth surface, click on the surface (right) select *Properties* and change *Fill shading* to Gouraud.

### 3.2.6 iContour

For a description see iSurface above.



Screenshot of iContour after startup.

### 3.2.7 ilmage

For a description see iSurface above.

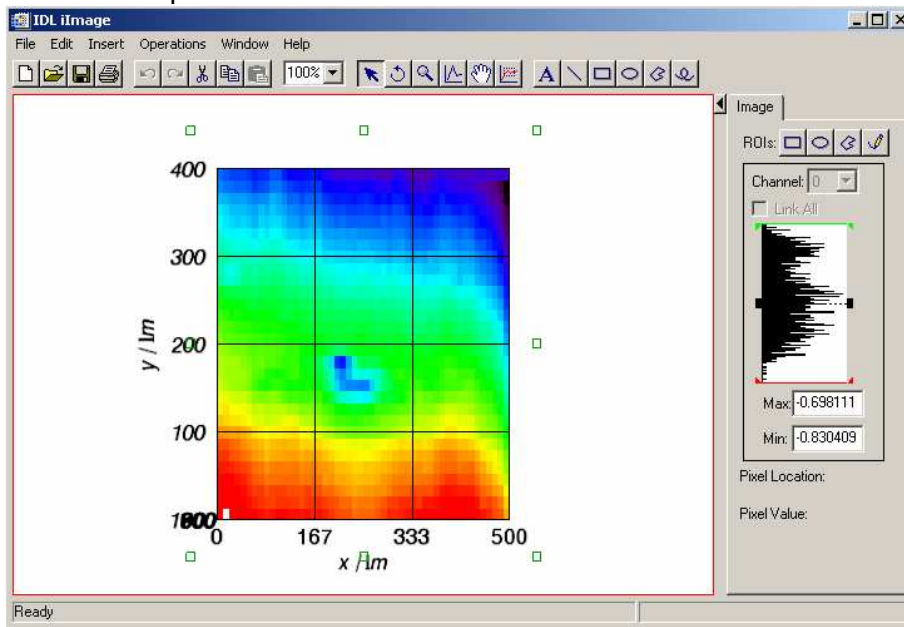

Fig. 25: Screenshot of ilmage after startup.

### 3.2.8 iPlot

This plot is started with a data set only if a 2D data set is active in *Single Plot* or *Multiplot*. The operation is generally the same as described for iSurface.

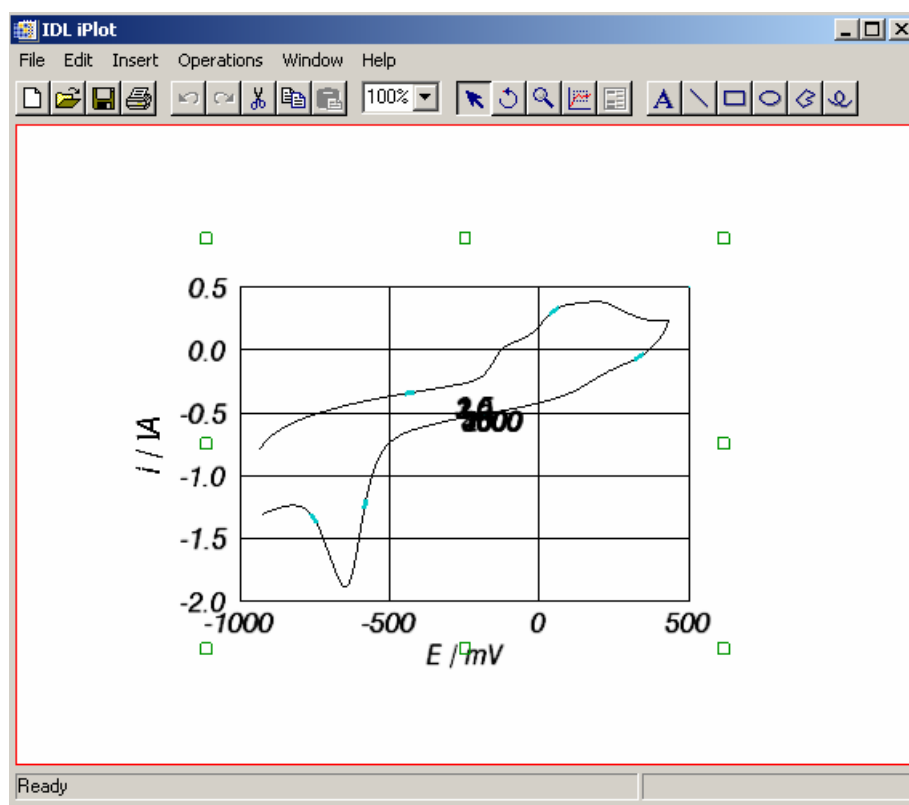

Fig. 26: Screenshot of iPlot after startup.

### 3.3 Data

#### 3.3.1 Subsets

##### Subset for Image data

Select the range between the given borders for X- and Y-Axis. Acknowledge by a changed made by the mouse pointer by pressing **<Update-1>** to transfer the selcted range into the text field. Press **<Update-2>** to make the entries in the text fields the setting for further processing

You can go back to the start-up values or close the window.

Example:

The complete data set is shown in the upper right graph of the form. You can select a subset for closer inspection (Fig. 27). You can either give the index in the text field and press **<Update-2>** below. Alternatively, you can simply draw left-click on the lower left corner, hold the mouse button, drag to the upper right corner and release. The selected section will appear in the lower window. You can repeat this process many times. Press **<Update-1>** the coordinates will be updated in the text windows and on the main program. For changing the axis or legend format use options of *Axis Format*.

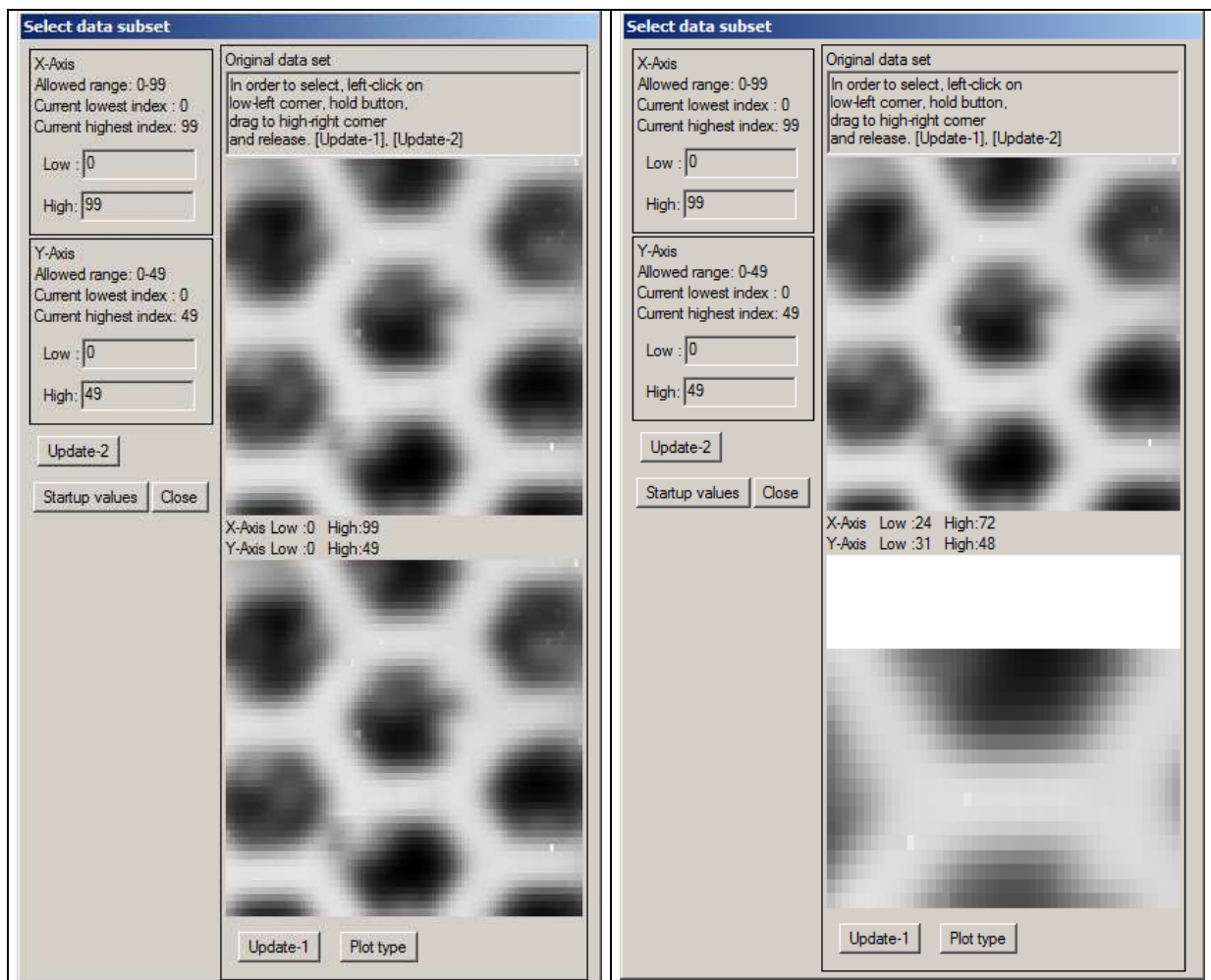

Fig. 27: Subsets: Plot before and after selecting a region of interest.

### Subset for 2D data sets

The window in Fig. 28 appears. It shows in the left column the complete data set. In the top axis the data sets are shown versus the original abscissa, e.g. potential in a cyclic voltammogram. Below the same data set is plotted vs. time. A multi-cycle CV is than shown in a way that each x value occurs only once. For a chronoamperogram, both plots provide the same plot. The subset is selected by left click (lower boarder) and right click in the **lower left image**. If the lower limit is below the upper limit the subset is immediately shown on the right (otherwise no action is taken). The plot show in the top the y values vs. the original abscissa. The low plot shows the selected y-values vs. time. The selected range can be fin-adjusted by the text field below the right plots. The current selection is highlighted in blue in the left plots,

Use **<Startup>** to get the original date set.

Use **<Cancel>** to leave the window and maintain the previous selection.

Use **<Ok + Close>** to accept the current selection and to close the window.

Use **<Update-3>** to transfer the index range selected in the graph to the text field.

This can be used to extract one by one all individual chronoamperograms from the plot and export them from MIRA to ASCII before selecting the next pulse for export.

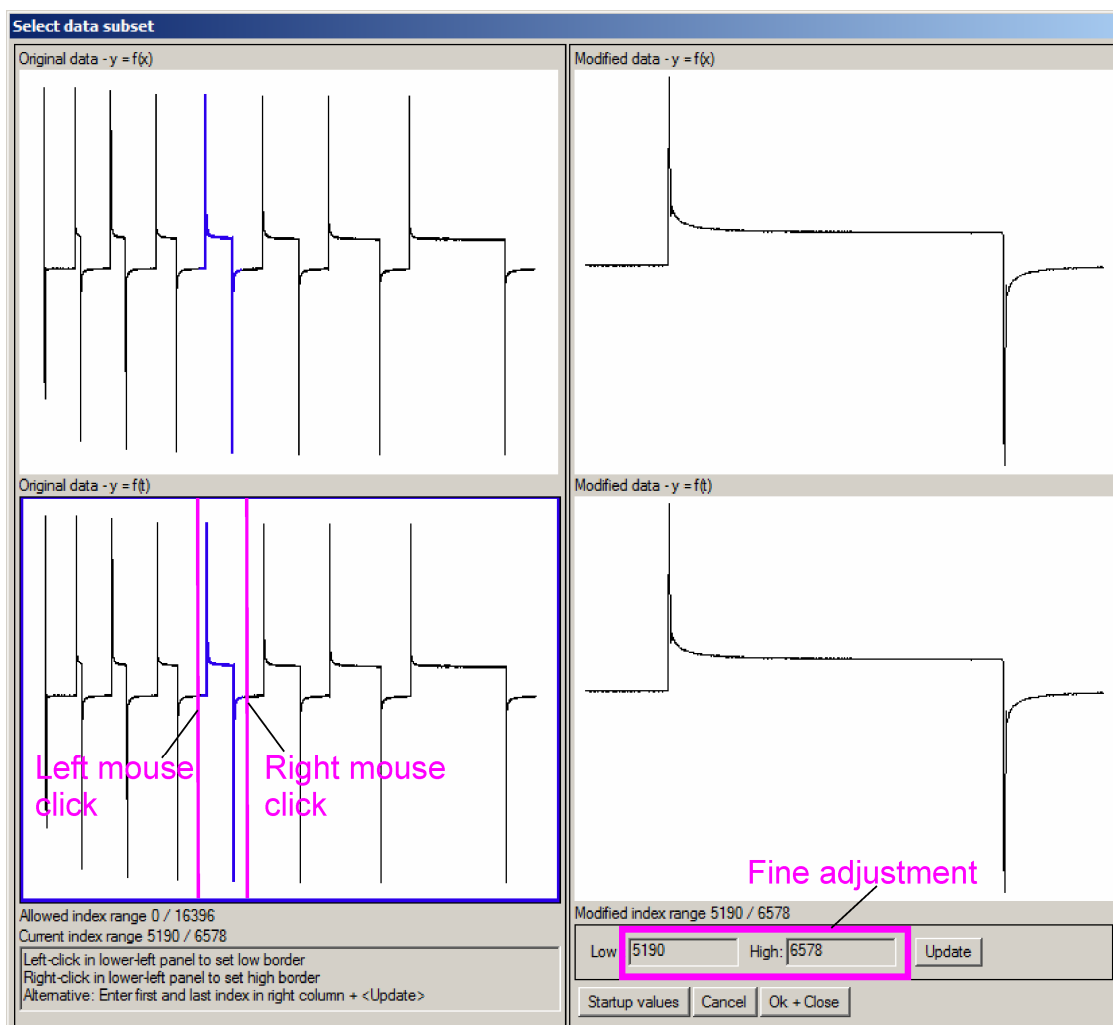

Fig 28: Window for selecting subsets from a x,y-data set.

**Subset for 4D data sets**

For 4D data sets subsets can be selected with respect to the two spatial coordinates similar as for 3D data sets in Fig. 27. In addition, the index range of the third independent variable can be selected similar to Fig. 28. In the field with the full image range you select the range of x,y-coordinates by left-click. Use right-click to select the dependent dataset for display in the graph for the 2D data sets. The index range for the 2D datasets is selected by left- and right- click in the graph of the 2D data set, similar to Fig. 28.

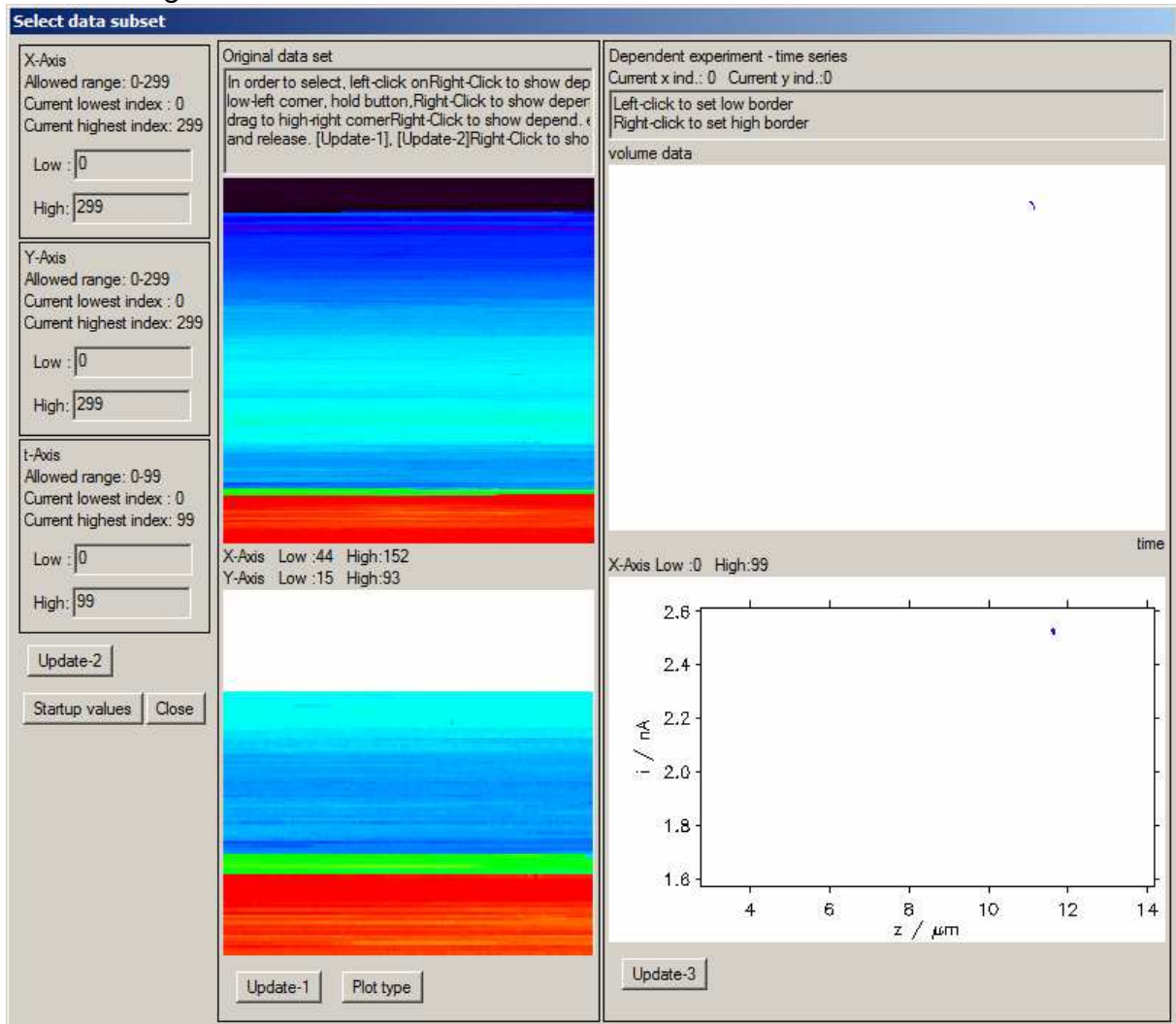

Fig 28: Window for selecting subsets from a x,y,z,t-data set.

**3.3.2 Resize array**

Change the array dimensions. Enter the favored factor to increase the pixel number in each direction. The new number of points is calculated by new pixel number = old pixel number \* FX or pixel number = old pixel number \* FY.

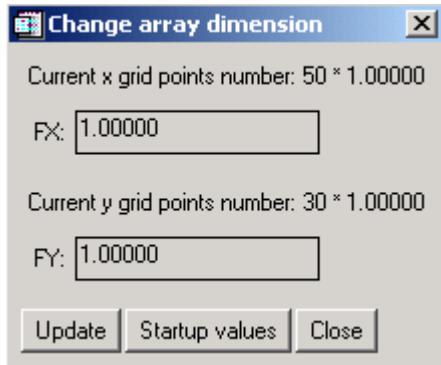

Fig. 30: Resize Array

### 3.3.3 Arithmetic

This function gives the chance to perform arithmetic transformation of the x, y or z data sets.

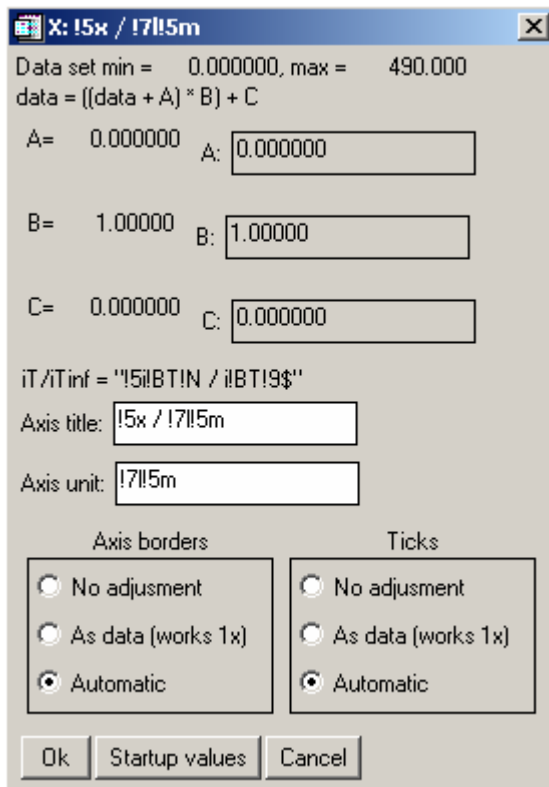

Fig. 31: Arithmetic, main screen

To normalize your data it is possible to multiply with constant value. You can also add a constant. Axis borders can be adjusted with the data set. **Data cutoff**

According to the smallest and the highest value for z you can cut off a part of your data range by changing the high or low border.

Figure 32 shows an area of a plot in which there are many spikes.



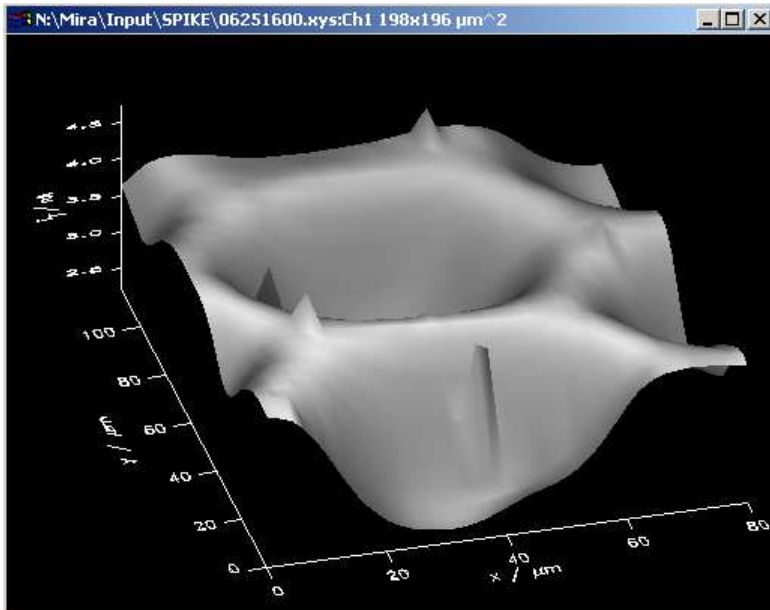

Fig. 32: Data cutoff: Spike area before flattening

To give an idea about the amplitude of the spikes another plot seems more practical:

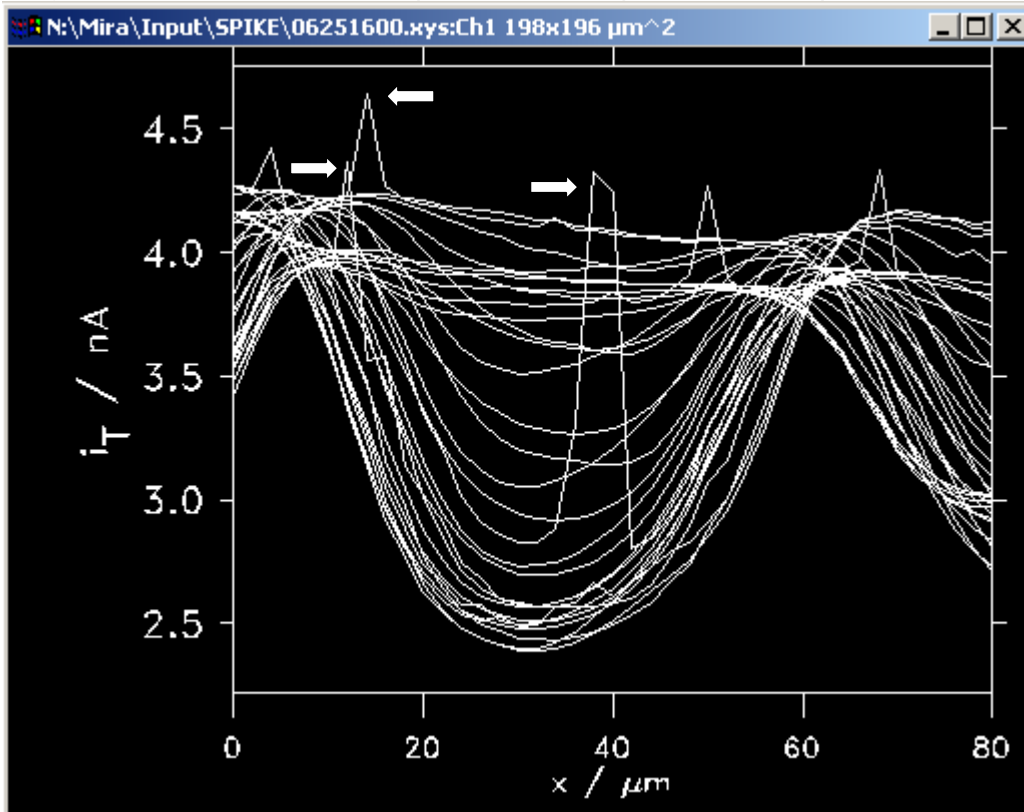

Fig. 34: Data cutoff: Spike area, shown in a two-dimensional plot

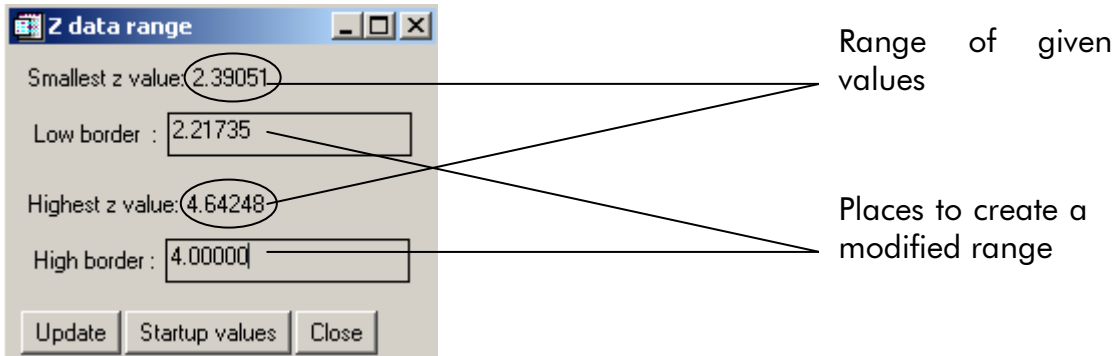

Fig. 35: Data cutoff, main screen.

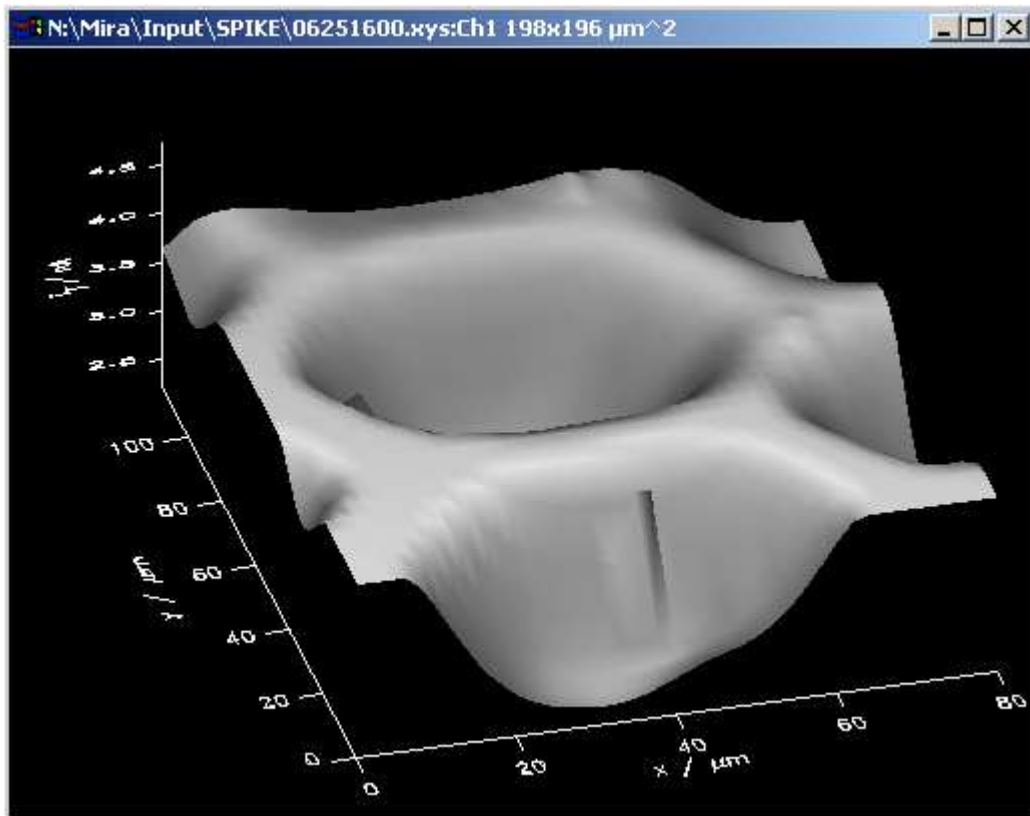

Fig. 36: Data cutoff: Plot after cutting the z data range.

The 2D plot will show the effect much more obvious:

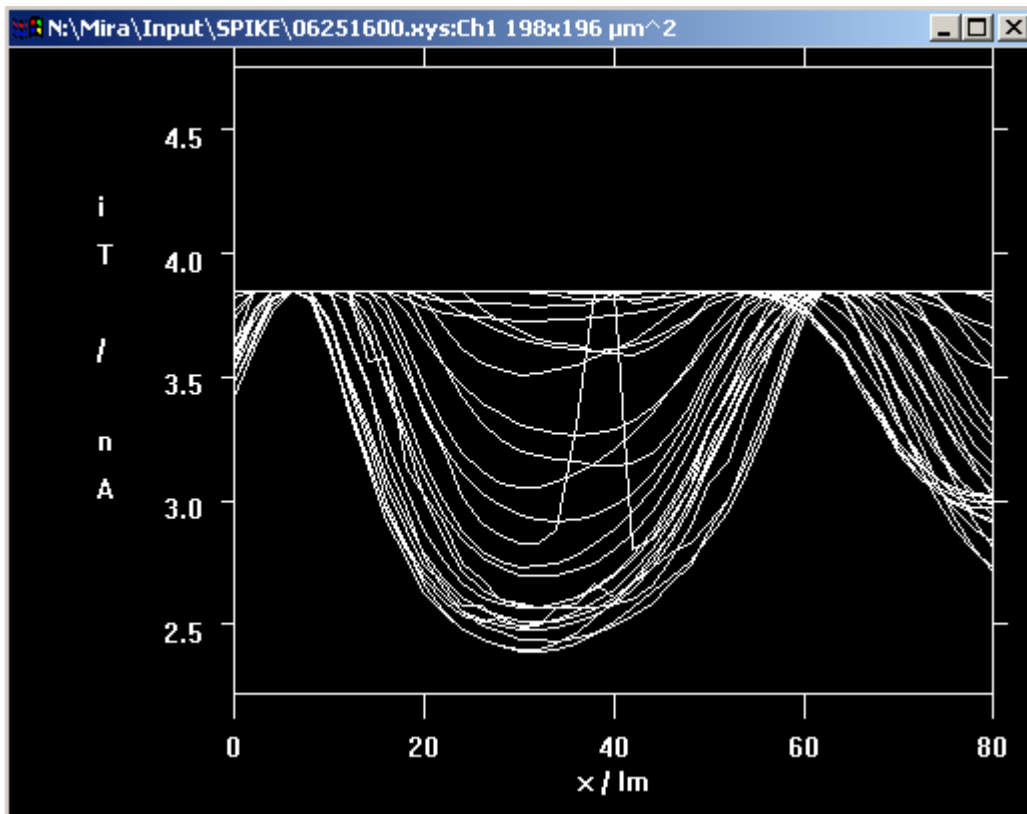

Fig. 37: Data cutoff: This setting of data cutoff value clips a considerable portion of the data points to the maximum value.

### 3.3.5 Rotate array

If you want to rotate your data set within the fixed coordinate system mark the choice of transformation. The program is able to rotate and transpose on 90°, 180°, 270°.

### 3.4 Plot format

#### 3.4.1 Handle volume data (old SECMx data files)

Volume data are data in which the probe performs the same mechanical movement as in imaging. However, at each grid point a complete 2D experiment (e.g. cyclic voltammetry or chronoamperometry) is performed. This experiment is called dependent experiment. These data can only be plotted on a 2D paper by a projection. The Handle Volume data window provides access to automatize these functions. It shows an image (upper part) of the projected data and a time trace of the selected grid point in the image. In the example the lowest left point is selected and marked by a white rectangle around the point. If the projection method is *Slice number*, the slice to display can be selected by the cursor in the time trace (vide infra).

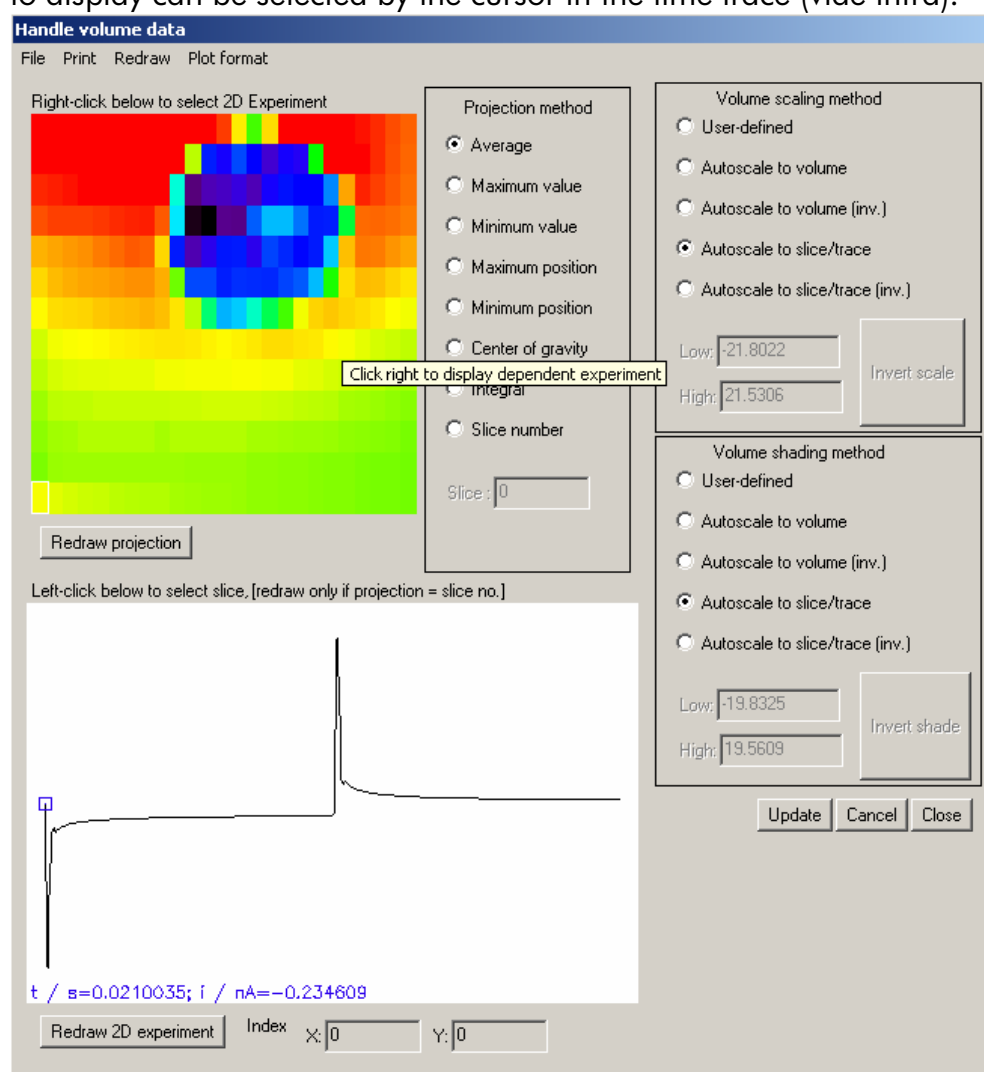

Fig. 38. Handling of volume data (old version).

In order to obtain an image, the data at each grid point must be compressed to one data value. The method is selection by the radio buttons right of the image.

Average	The image is composed of the average y values of each of the dependent 2D experiments.
Maximum value	The image is composed of the maximum y values of each of the dependent 2D experiments.

Minimum value	The image is composed of the minimum $y$ values of each of the dependent 2D experiments.
Maximum position	The image is composed of the $x$ value of each of the dependent 2D experiments at which the maximum signal was recorded.
Minimum position	The image is composed of the $x$ value of each of the dependent 2D experiments at which the minimum signal was recorded.
Center of gravity	The image is composed of center of gravity $r$ of the dependent 2D experiments at which the maximum signal was recorded. $r = \frac{1}{n} \sum_{i=0}^{n-1} x_i y_i$ (x and $y$ are the data pairs of the dependent experiment)
Integral	The image is composed of the integral of each 2D experiment.
Slice number	The image is composed of the $y$ value of slice $n$ of each 2D experiments.

The button *Redraw* projection causes the current projection to be redrawn in a separate graph window using the plot type selected in the main SPM window.

The *Redraw 2D experiment* causes a the currently selected time trace to be redrawn in a separate window as  $x,y$ -plot. Note there is a difference between time trace and  $x,y$ -plot, especially for cyclic voltammograms. The time trace in Fig. 38 shows the data a  $y = f(t)$ . The plot  $y = f(x)$  can also give a loop if  $x$  is a triangle voltage ramp.

The radio button *Volume shading method* and *Volume scaling method* works in connection with the menu option *Print/Print all slices*. This option exports a  $n$  images, one from each slice. The  $z$  axis is scaled according to the selection of the scaling method and the shading is made with the selection specified with *Volume shading* option. The  $n$  images can be combined to a movie that reflects the change of the signal in space and time.

The menu options are similar to other menus.

File/Return trace (2D) + Close	Returns the current trace as new 2D data set. The information on the 4D volume data is lost in SPM window, closes the window
File/Return projection (3D) Close	Returns the current projection as new 3D data set. The information on the 4D volume data is lost in SPM window, closes the window
Close	Closes the window
Cancel	Closes the window
Print/Selection of graphic format	Selects the graphic format for later output
Print/System printer	Selects the printer for later printing
Print/Print current projection	Prints the current projection to file or printer
Print/Print all slices (img)	Prints a series of all slices to file (for making a movie)
Print/Print current trace (2D)	Prints the current $x,y$ experiment to file
Print/Print all traces (2D)	Prints all $x,y$ experiments to file
Redraw/Redraw current projection	Redraws the current projection to a graph window

Redraw/Redraw all slices (img)	Redraws a series of all slices to a graph window (for inspecting a movie)
Redraw/Redraw current trace (2D)	Redraws the current x,y experiment to a graph window
Redraw/Redraw all traces (2D)	Prints all x,y experiments to a graph window
Plot format/Axis format	Allows to explicitly set axis format of x,y,z, time and x variable of the dependent experiment
Plot format/Scale user shade	Allows to set all the options for the user scale to plot the projections

### 3.4.2 Handle volume data (new SECMx data files)

Volume data of newer SECMx data files are treated in an updated volume handler with more options. In volume experiments the probe performs the same mechanical movement as in imaging. However, at each grid point a complete 2D experiment (e.g. cyclic voltammetry or chronoamperometry) is performed. This experiment is called dependent experiment. These data can only be plotted on a 2D paper by a projection.

The Handle Volume data window provides access to automatize these functions. It shows an image (upper left part) of the projected data and a time traces of the selected grid point in the image (right column). The time trace is shown vs. time (top) and vs. the dependent x-data (bottom). Hier the dependent x-data are a the potential ov a CV and therefore both plots are different. In case ov a chonoamperogram as dependent experiment, both plot would look identical. A point of the right 'hot' region is selected and marked by a white rectangle around the point. If the projection method is *Slice number*, the slice to display can be selected by the cursor in the time trace (vide infra) or by an edit field below the image.

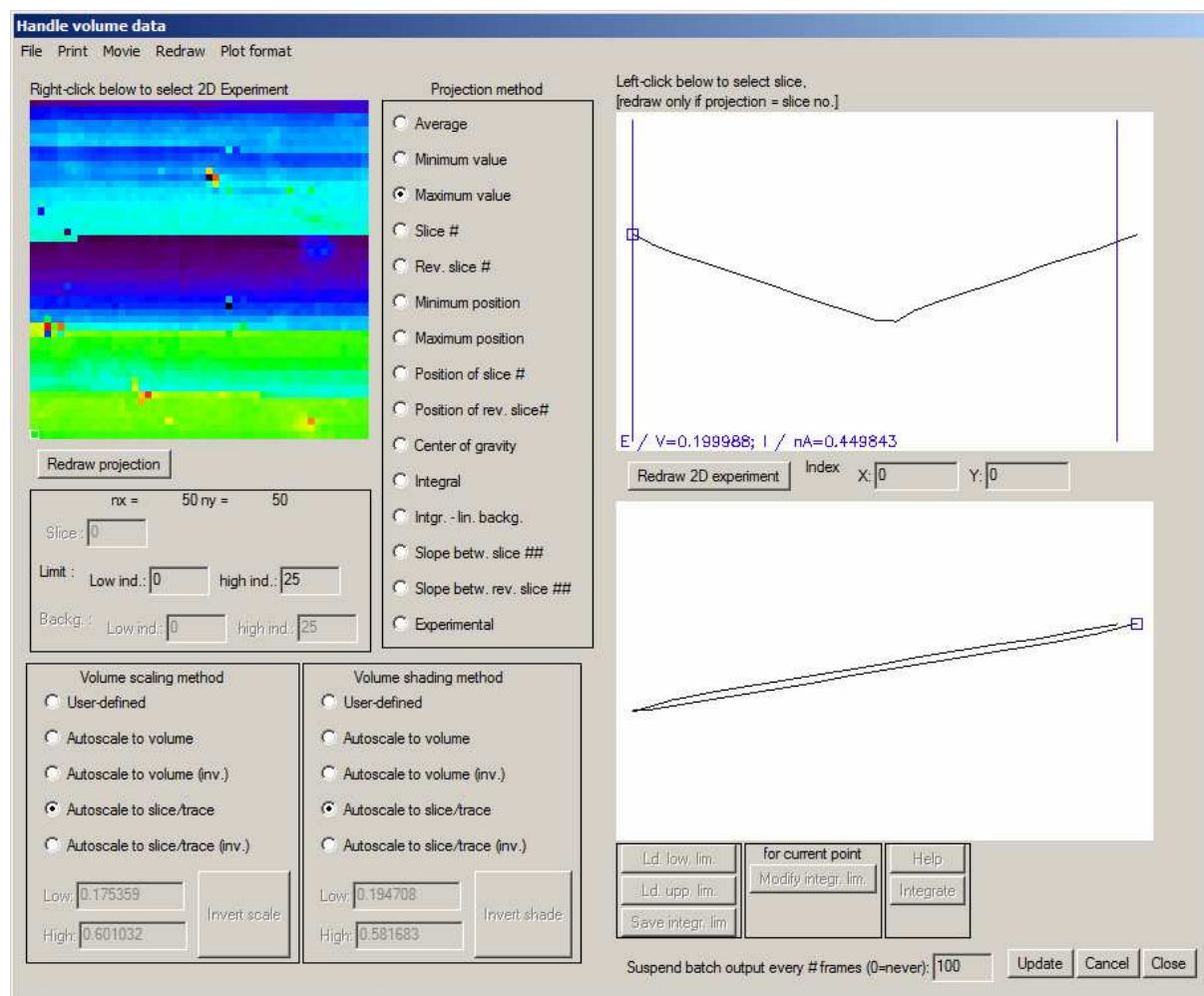

Fig. 39. Handling of volume data (new version). The projection method is slice.

In order to obtain an image, the data at each grid point must be compressed to one data value. The method is selection by the radio buttons right of the image.

Average	The image is composed of the average $y$ values of each of the dependent 2D experiments.
Maximum value	The image is composed of the maximum $y$ values of each of the dependent 2D experiments within the limit (low ind./high ind.).
Minimum value	The image is composed of the minimum $y$ values of each of the dependent 2D experiments within the limit (low ind./high ind.).
Slice #	The image is composed of the $y$ value of slice $n$ of each 2D experiments.
Rev. slice #	The image is composed of the $y$ value of slice $n$ counted from the end of this experiment. In some cases experiments can have different numbers of data points (if a scan is interrupted when reaching the surface). The count is from the last point in the data set.
Minimum position	The image is composed of the $x$ value of each of the dependent 2D experiments at which the minimum signal was recorded within the limit (low ind./high ind.).
Maximum position	The image is composed of the $x$ value of each of the dependent 2D experiments at which the maximum signal was recorded within the limit (low ind./high ind.).

Position of Slice #	The image is composed of the $x$ value of slice $n$ of each 2D experiments.
Position of rev. slice #	The image is composed of the $x$ value of slice $n$ counted from the end of this experiment. In some cases experiments can have different numbers of data points (if a scan is interrupted when reaching the surface). The count is from the last point in the data set.
Center of gravity	The image is composed of center of gravity $r$ of the dependent 2D experiments at which the maximum signal was recorded. $r = \frac{1}{n} \sum_{i=0}^{n-1} x_i y_i$ (x and $y$ are the data pairs of the dependent experiment)
Integral	The image is composed of the integral of each 2D experiment within the limit (low ind./high ind.).
Integral - linear background	The image is composed of the integral of each 2D experiment within the limit (low ind./high ind.). versus a linear background formed by a line between the points indicated by data point with indices "Backg low ind./high ind." .
Slope betw. slice ##	The image is composed of slope of a linear regression between the points (low ind./high ind.).
Slope between rev. slice ##	The image is composed of slope of a linear regression between the points (low ind./high ind.) counted from the end of each 2D experiment.
Experimental	This is an option for the internal testing purposes. Currently this allows image extraction with flexible integration limits that can be loaded from *.csv data sets using the command buttons in the lower right part of the screen. Separates files are used for lower and upper integration limits. The limits are given as the index of the first data point. The index is also used to construct a linear background between the two data points.



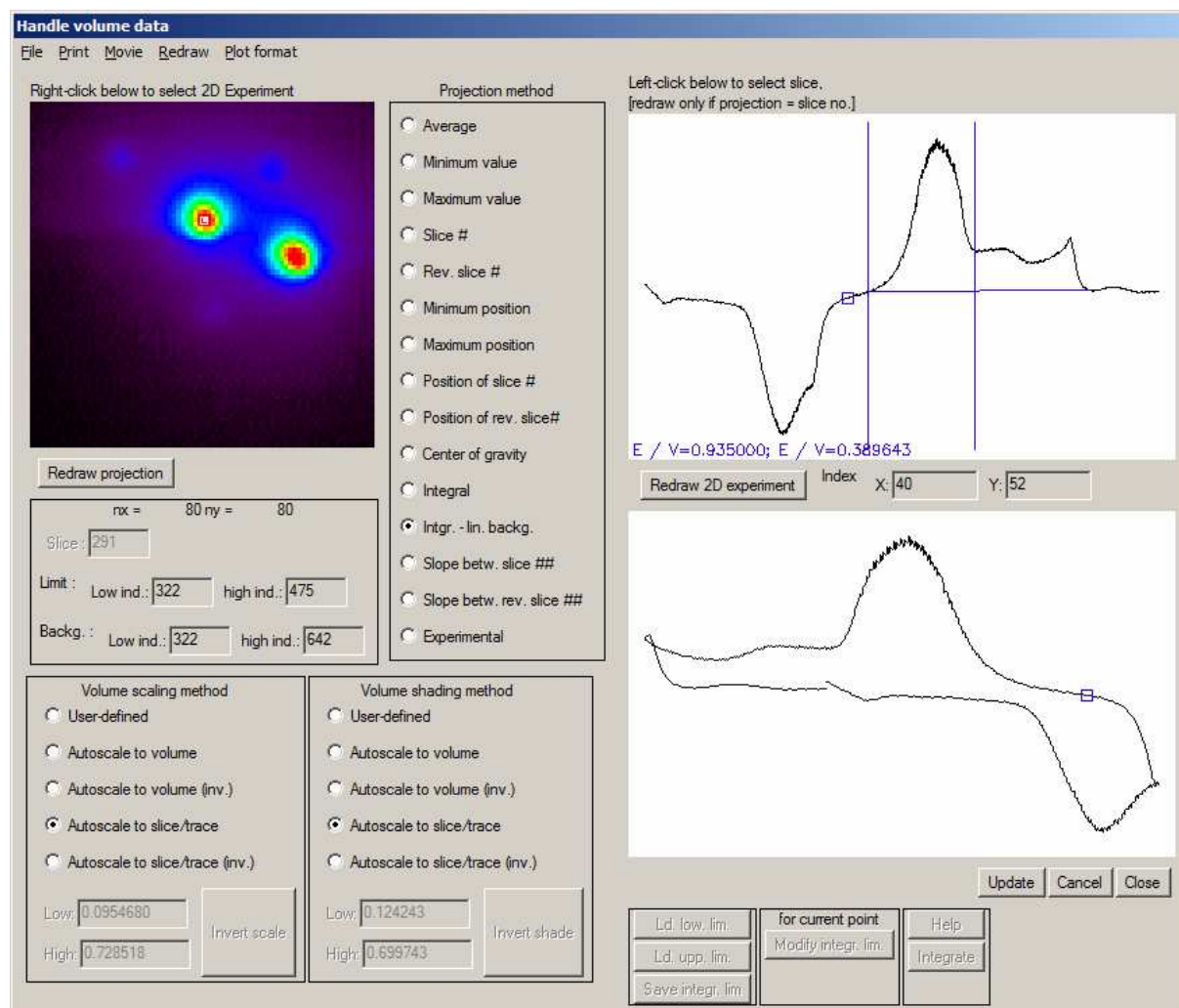

Fig. 40. Handling of volume data (new version). The projection method is integral - background.

The button *Redraw projection* causes the current projection to be redrawn in a separate graph window using the plot type selected in the main SPM window.

The *Redraw 2D experiment* causes a the currently selected time trace to be redrawn in a separate window as x,y-plot. Note, there is a difference between time trace (top) and x,y-plot (below), especially for cyclic voltammograms.

The radio button *Volume shading method* and *Volume scaling method* works in connection with the menu option *Print/Print all slices*. This option exports *n* images, one from each slice. The z axis is scaled according to the selection of the scaling method and the shading is made with the selection specified with Volume shading option. The *n* images can be combined to a movie that reflects the change of the signal in space and time.

The menu options are similar to other menus.

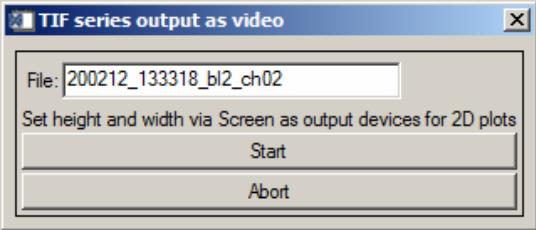
File/Return trace (2D) + Close	Returns the current trace as new 2D data set. The information on the 4D volume data is lost in SPM window, closes the window
File/Return projection (3D) Close	Returns the current projection as new 3D data set. The information on the 4D volume data is lost in SPM window, closes the window
Close	Closes the window
Cancel	Closes the window
Print/Selection of graphic format	Selects the graphic format for later output
Print/System printer	Selects the printer for later printing
Print/Print current projection	Prints the current projection to file or printer
Print/Print all slices (img)	Prints a series of all slices to file (for making a movie)
Print/Print current trace (2D)	Prints the current x,y experiment to file
Print/Print all traces (2D)	Prints all x,y experiments to file
Make/Test movie on screen	outputs a sequence of evenly scaled images to a screen window. If option trace is used, the 2D plot (usually CV or approach curve) with a moving cursor is added.
Movie/Make movie from slices and traces  Movie/Make movie from slices	<p>Creates a sequence of TIF files and save them to the output path. The width and height is determined under <i>Print/Graphic selection</i> <a href="#">under the item Screen for 2D plots!!!</a> For presentation purpose, it is recommended to make the export in exactly the same size as needed for a screen presentation.</p> <p>Before output is started user should confirm the stem of the file names for the output files. The number of slice is appended. THE TIF fiels must be merged by an external program.</p> 
Redraw/Redraw current projection	Redraws the current projection to a graph window
Redraw/Redraw all slices (img)	Redraws a series of all slices to a graph window (for inspecting a movie)
Redraw/Redraw current trace (2D)	Redraws the current x,y experiment to a graph window
Redraw/Redraw all traces (2D)	Prints all x,y experiments to a graph window
Plot format/Axis format	Allows to explicitly set axis format of x,y,z, time and x variable of the dependent experiment
Plot format/Scale user shade	Allows to set all the options for the user scale to plot the projections

For routines like 'Print all slices' and 'Make video from slices', the routines stops after n images frames and request a conformation to continue. This give the option interrupt length procedures that do not produce the desired result. The window appears in the far left corner of the screen regardless of the position of the L4D2 window.

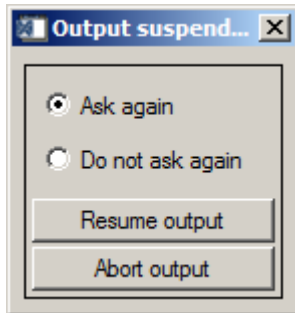

### 3.4.3 Create view

Change the values for the graphic axis.

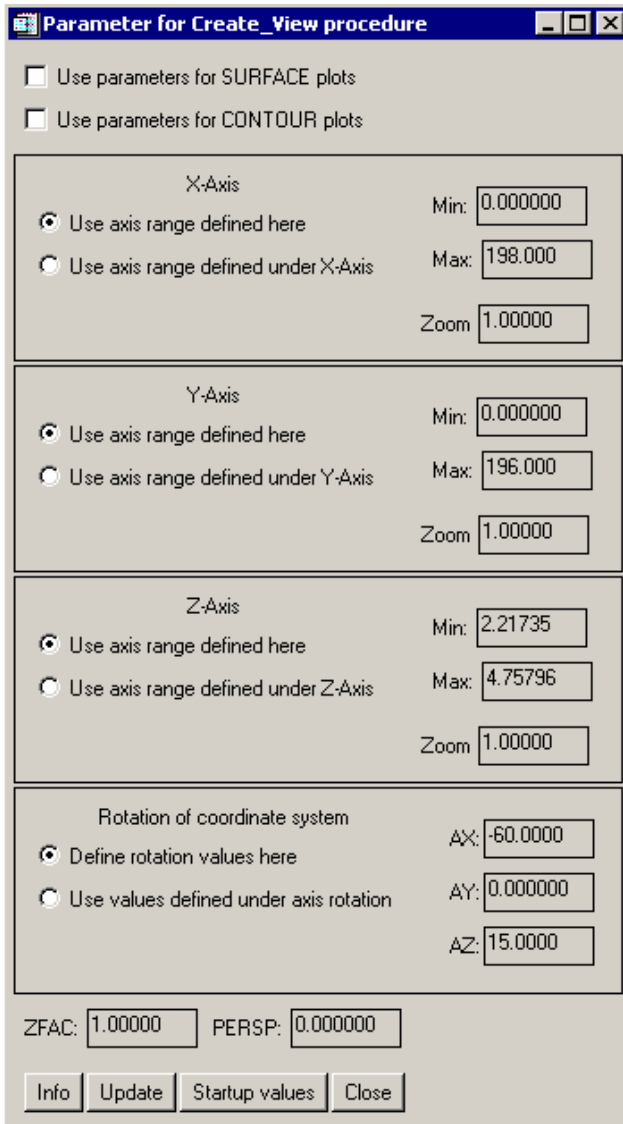

Fig. 41: Create view.

If you want to create a plot with a 3D coordinate system whose length is proportional to the real length in each direction you can define the viewing options here. This is good if the imaged areas deviates much from a square.

### 3.4.4 Plot-dep. margin

By choosing this function you will be able to change the plot-depending margin parameters. Startup values are given to which you can go back.

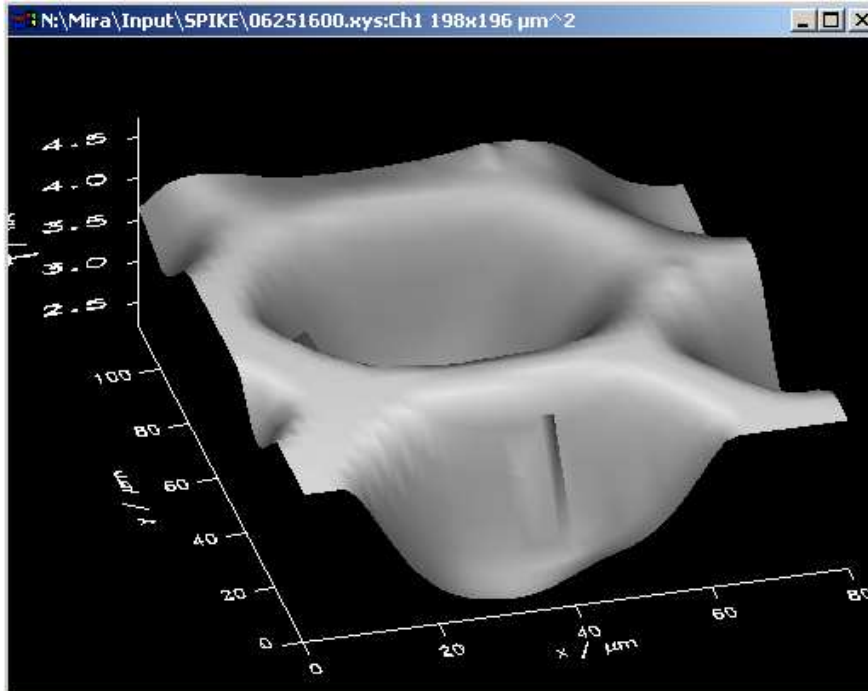
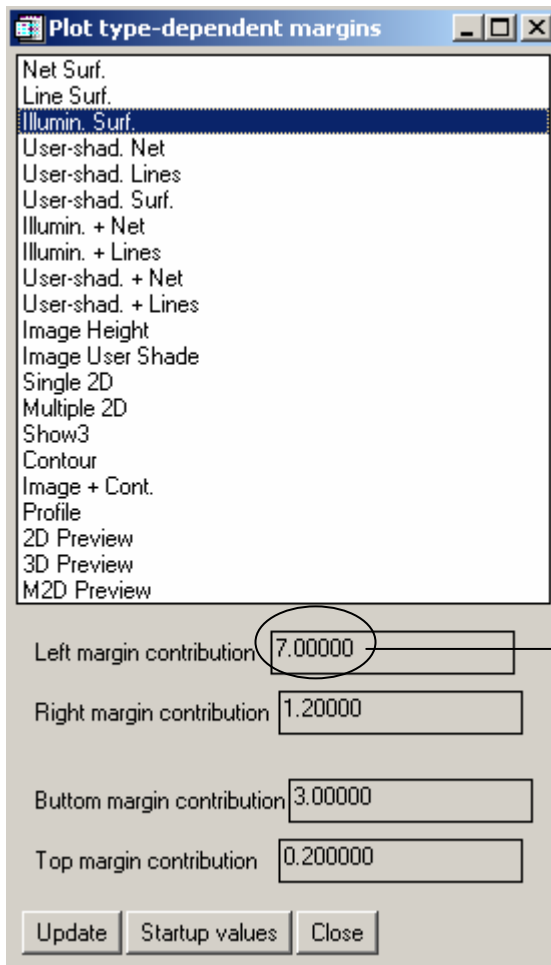

Fig. 42: Plot-dep, margin: Before changing margin.

As you can see in this plot (Fig. 42) the left margin should be set higher to make the axis label of the z axis readable. Choosing *Plot-dep, margin* the following window will appear:



Value which should be corrected

Fig. 43: Plot-dep. margin, main screen.

Standard values are given for every margin.

Changing the marked value into 10.00000 the result look like this:

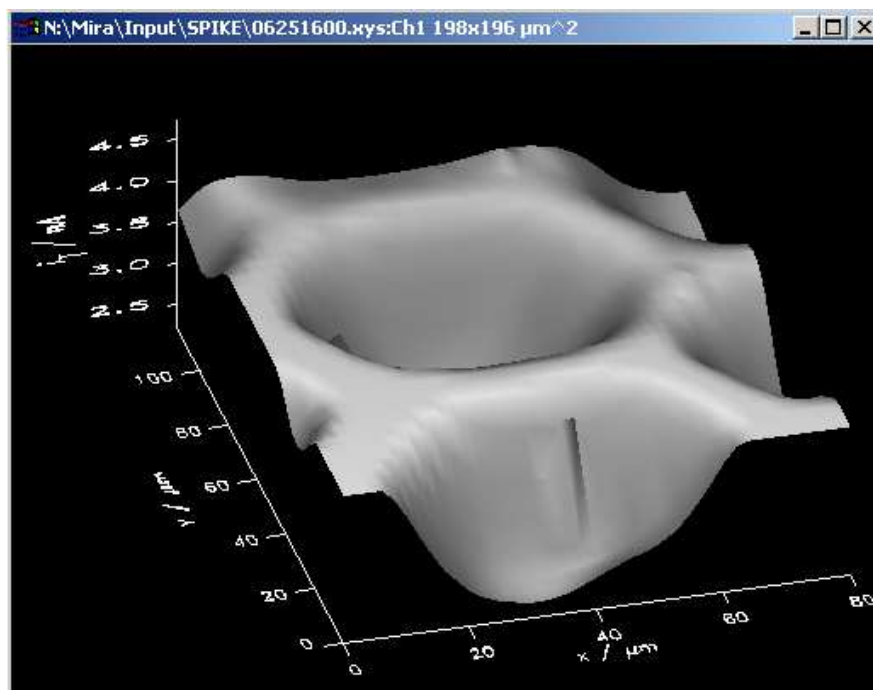

Fig. 44: Plot-dep. margin: Plot after correcting the margin contributions.

As you can see in Figure 44 the axis title fits into the plot window.

Note: The appearance of margins may vary between screen output and different graphic formats and between different plot types. There are two contributions to the margin: one contribution depending on the output format (Screen, eps, tif, ...) and one depending on the plot type (surface, image, 2D line graph). Here adjustment should be made print all parts of the plot in the draw area (independent of the plot type). Sometimes graphs require a change of the margins (e.g. if the tick labels at the vertical axis have different numbers of significant digits ("1.5" vs. "1.558"). This would affect all possible output formats and therefore the change should be made here. Another problem with margin is that they may be o.k. on screen output but not when printed to TIF. This adjustment should be made under [File/Selection of graphic formats](#) and the settings there (section 3.1.7).

### 3.4.5 Plot region

Sets the limits of the plot region. This can be set here but will only affect Combined Plots. The position of the Single Plot is controlled only with the Plot-depending and hardware depending margins.

→ *Combined Plot: Example 2 - Create a Stacked Surface plot*

### 3.4.6 Skirt

Insert a skirt to your plot.

This option is only possible if you took a line- or net-structured plot. Every dot at the margin of the image is connected to the basis by a line.

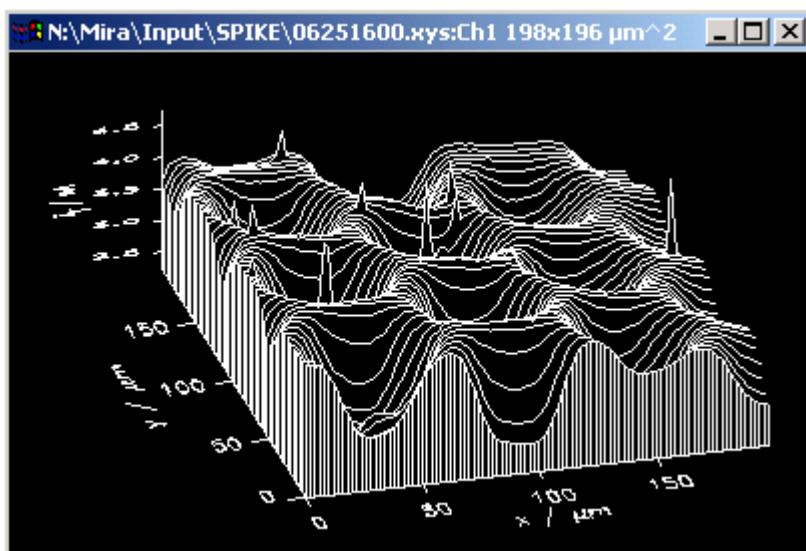

Fig. 45: Skirt: Plot including a skirt.

### 3.4.7 Axis rotation

Changing the rotation of the coordination system to get another view of the plot. Vertical and horizontal rotation is possible. For a rotation around the x axis the size of the labels for the z axis will be automatically adjusted. For high quality output a manual correction as described in Section 3.4.8 may be required.

### 3.4.8 Axis format

Here settings are made that are specific to one axis. This includes the number, position and labelling of tick marks. Additional tick marks may be introduced and labelled to make locations (e.g.  $x = 120$ , Label "A";  $y = 40$ , Label "A" to make the location of a feature "A" at (120, 40)).

A further common need is to adjust the relative size of the labels for the z axis in surface plots. Starting from August 2015, a rotation AX of a surface plot (section 3.4.7) will automatically lead to an internal adjustment of the letter size for the z axis. If the result is not satisfying or if special affects are required, the character size and character thickness relative to the other axes can be adjusted here as illustrated in Figure 46 to 48.

Note on character size. The size of a particular label will be determined by the combined action of three settings:

Char. size as Width and Height (in arbitrary units) given in the Font system settings (section 3.4.13)

Character size (section 3.1.7) given separately for each graphic format to adjust the different appearance of the same plot in different graphic file formats.

Character size factor (section 3.4.8) that adjusts the relative size between the labelling of the x, y and z axes.

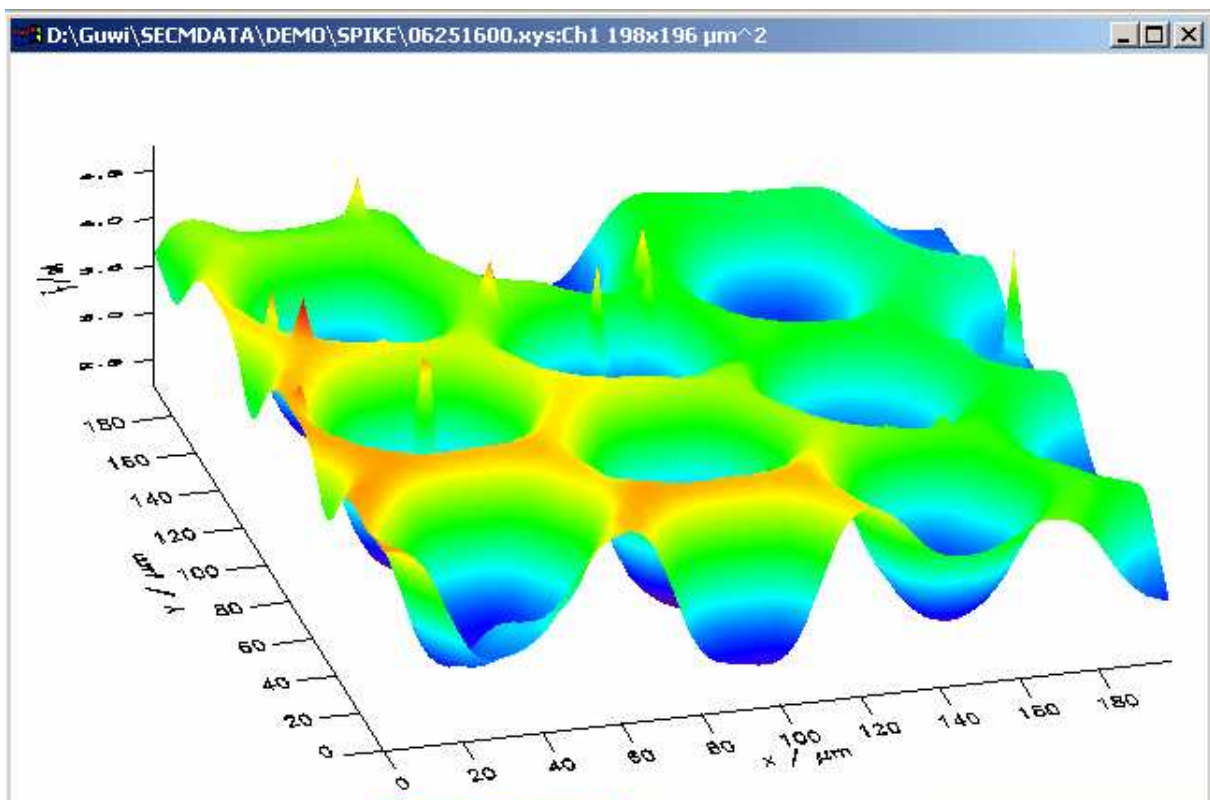

Fig. 46: Axis format: Plot before enlarging the values of z-axis.

As you can see in Figure 46 the legend of the vertical axis is too small and not readable.

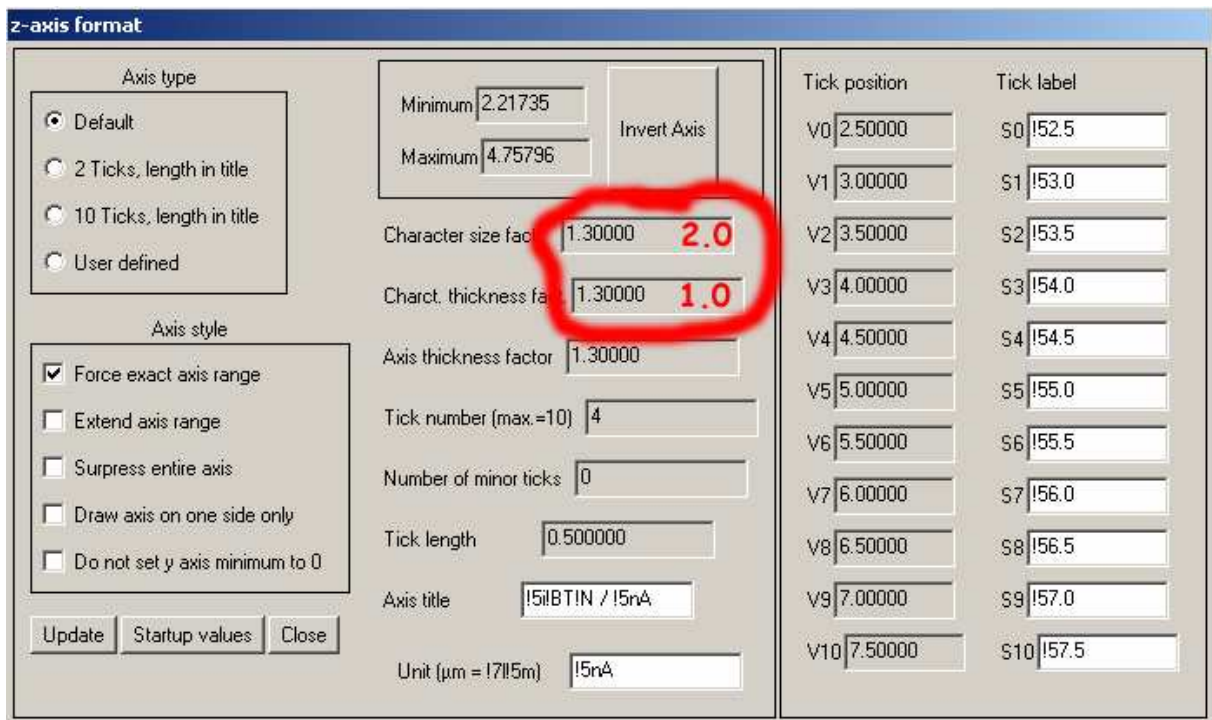

Fig. 47: Axis format - correction of character size and thickness of an individual axis.

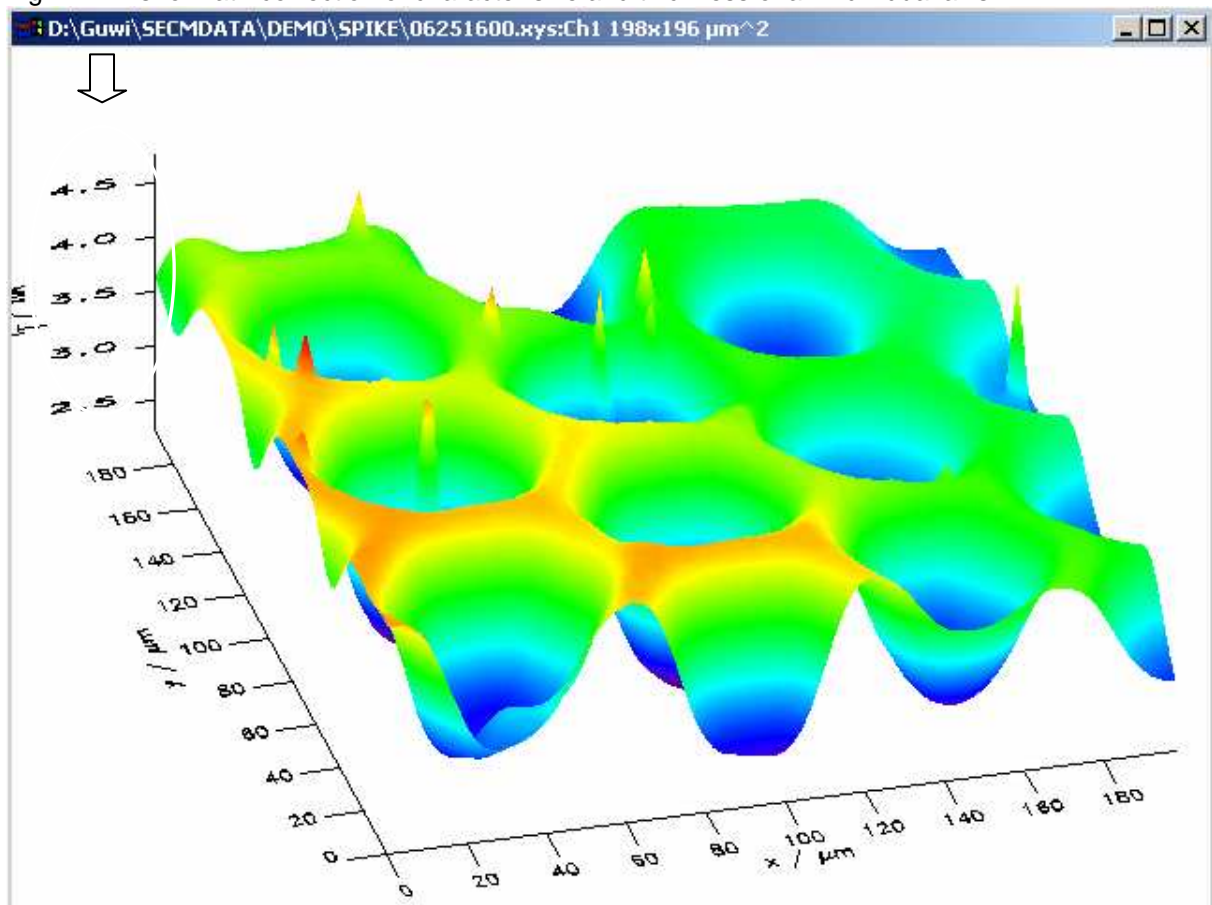

Fig. 48: Axis format: After enlarging the values beside the axis.

To change the margin contribution to complete the view of the axis information → *Plot-dep. Margin.*



### 3.4.9 Scale user shade

The form user scale can be used for two main purposes. The first one is to highlight small features on a rising background. Consider the following image. A small increase in the reduction current is present in the center of the image. In a standard 3D plot there are two problems (Fig. 49, right) i) the peak in reduction current points "downwards" ii) the shade does not highlight the feature because the slopy background cover a wider data range than the peak. This situation is quite common in SECM imaging with signals of small magnitude (e.g. from enzymatically active surfaces). One can enhance the image without altering the data itself, by inverting the content of the *Minimum* and *Maximum* text fields in the *Axis format* window. For this purpose, call *Plot format/Axis/Z* and invert minimum and maximum of the axis. Click *user defined* for axis type (Fig. 49, left).

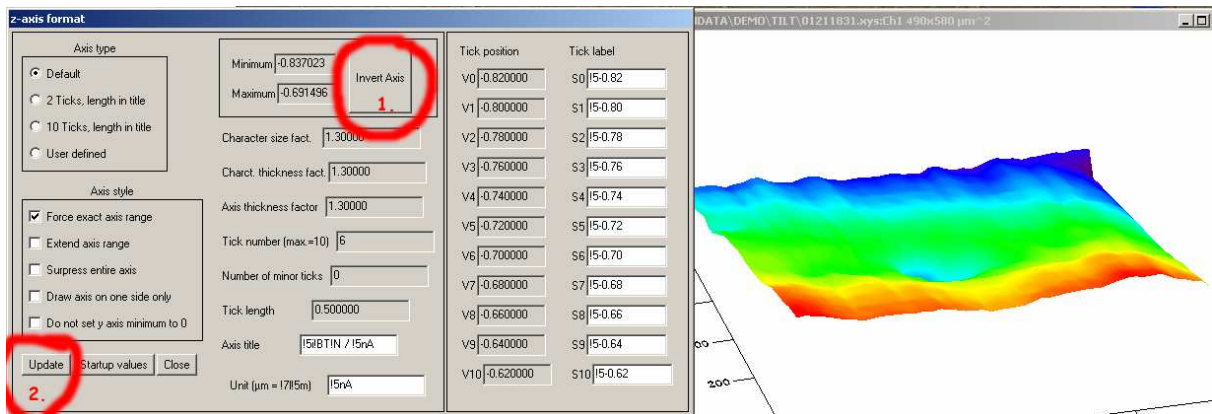

Fig. 49: Scale user shade: Only a part of the shade palette is used. The peak points "downwards".

Press **<Update>** in the *Plot format/Axis/Z* window and **<Redraw>** on the Single plot window. You should obtain the following graph.

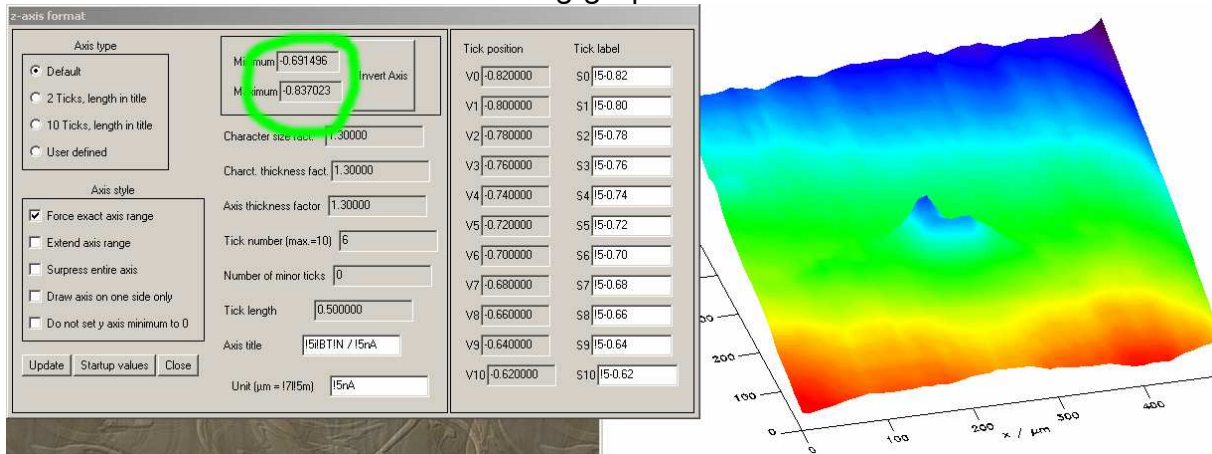

Fig. 50: Scale user shade: The peak points "upwards" now. The color shading is still not highlighting the feature in the center.

In order to use the scale of shades more effective than in Fig. 50, there are some options in the form *Plot format/Scale user shade*: The have in common, that a background is subtracted before converting the current values to a color scale. After subtracting the background, the resulting z array was scaled to the 0...254 (indicated in the left side of the image). This scales was used to color the surface plot. Gouraud interpolation was automatically used for the shading.

Furthermore, the color scale was inverted (option box in the lower left part of Fig. 51) and scaled to minimum and maximum values to make best use of the entire color scale. You can make any setting by selecting user-controlled shading. The inverted color scale emphasize that the feature is a maximum (in reduction currents) although arithmetically it is a minimum (reduction currents have a negative sign by IUPAC convention).

Please note, that in all cases the actual position of the z values is still the original. If you want to correct the z values itself and not just the shading (for tilt correction in a topographical AFM picture, use *Modify/Polynom flatten*, *Modify/Line by line flatten* and *Modify/Rolling sphere flatten*.

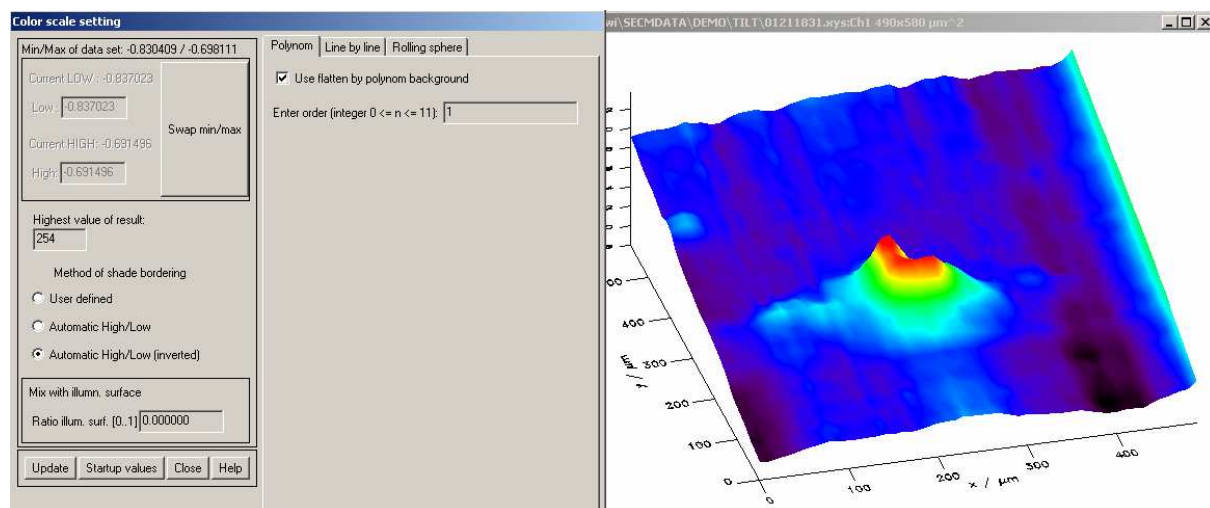

Fig. 51: Scale user shade with polynom background subtraction (order = 1, i.e. a plane) and the resulting plot.

Option a), see Fig. 51:

A polynom was fitted to the data set. this polynom was subtracted. The remaining variation in current was converted to a color scale. The order of the polynom can be between (0 = subtraction of a constant, 1 = subtraction of a tilted plane, ... 11). Experience shows that high polynom orders usually do not give good results. Try first 1 than 2 and so on. You also have to indicate in the Check Box "Use ..." that the polynom should be used.

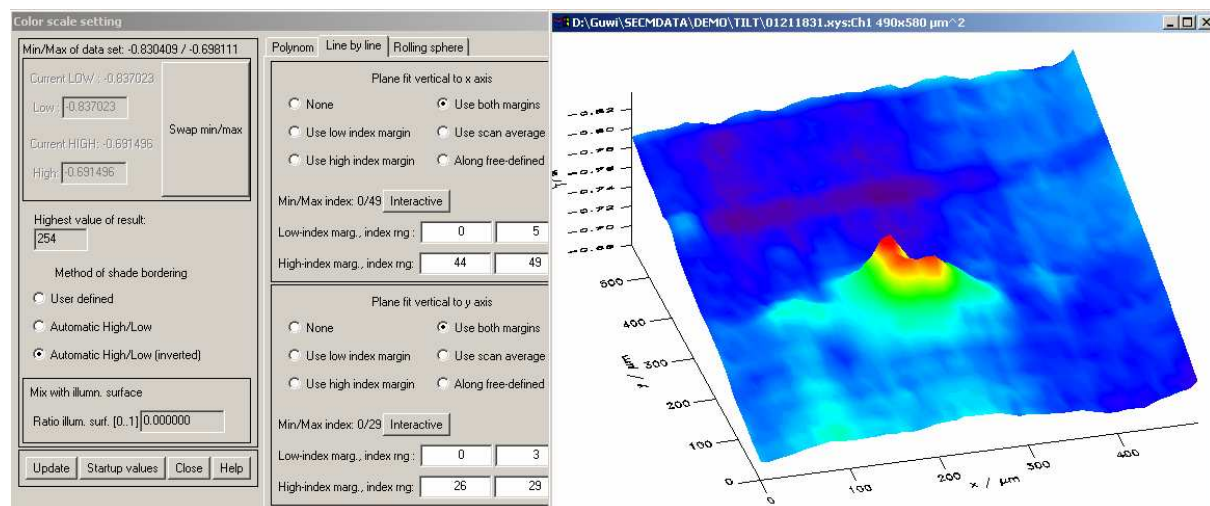

Fig. 52: Scale user shade with Line-by-Line background adjustment and the resulting plot.

Option b), see Fig. 52:

From z data at both margins of each line scan in x-direction and y-direction an average value of the currents for each scan was calculated. A temporary array for the z data was created. The mean values of each scan were subtracted from the measured z values. After subtracting the means of each line in x and y the resulting z array was scaled to the 0...254. The width of the margins used to calculate the mean of each line scan can be set by the white text boxes. For calculations of the mean you can use only one of the two margins, both margins or the entire line.

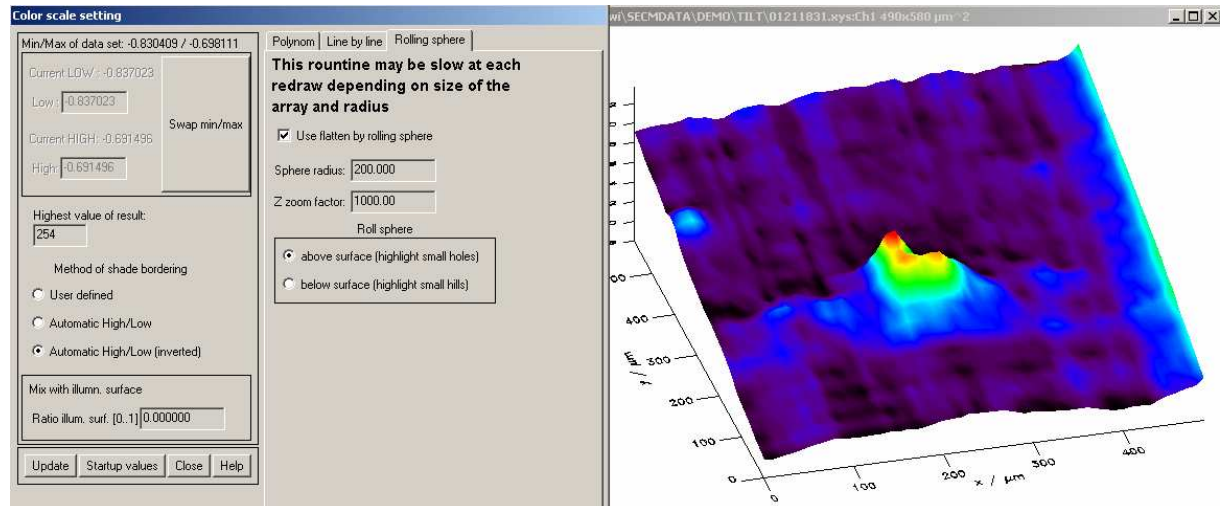

Fig. 53: Scale user shade with background adjustment by a rolling sphere above the data, followed by an inversion of the axis and the color scale and the resulting plot.

Option c), see Fig. 53:

The background calculation is done by calculating the path a sphere would roll above or below the data. If it rolls above, it highlights small depression, if it rolls below it highlights small elevation. Features of larger dimensions are removed. Important parameters are the size of the sphere and the z-zoom-factor that controls a stretching of the features during calculation.

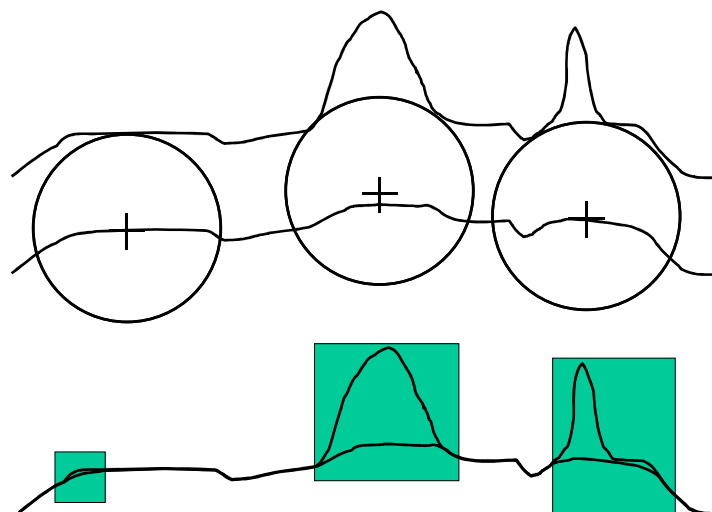

Fig. 54: Principle of the background removal by a rolling sphere. The path of the midpoint of the virtual sphere is taken as the background.

The second use of the *Plot format/Scale user shade* window is the creation of the hight proportional shading mixed with an illumination. Pure height-shaded images tend to hide small differences in data (the texture). An image that resembles how our eye receives texture is computed as an image  $d(i, j)$  that would arise from diffuse reflection of light. The incident light is described by a vector  $L$  (set by *Plot format/Light source*) and the surface normal  $N$ .  $N$  is computed for each image point  $z(i, j)$  from its four neighbors  $z(i-1, j-1)$ ,  $z(i-1, j+1)$ ,  $z(i+1, j-1)$ ,  $z(i+1, j+1)$ . The gray or false color value is then computed from the scalar product of  $L$  and  $N$  ( $|L| |N| \cos(\langle L, N \rangle)$ ). This algorithm together with Gouraud interpolation and consideration of ambient light and depth cueing is implemented in MIRA as well as in other image processing packages. The image computed for diffuse reflection and height scale can be mixed by a linear combination in different ratios. Set the contribution [0...1] of the illuminated surface in the text field right above the **<Update>**-button.

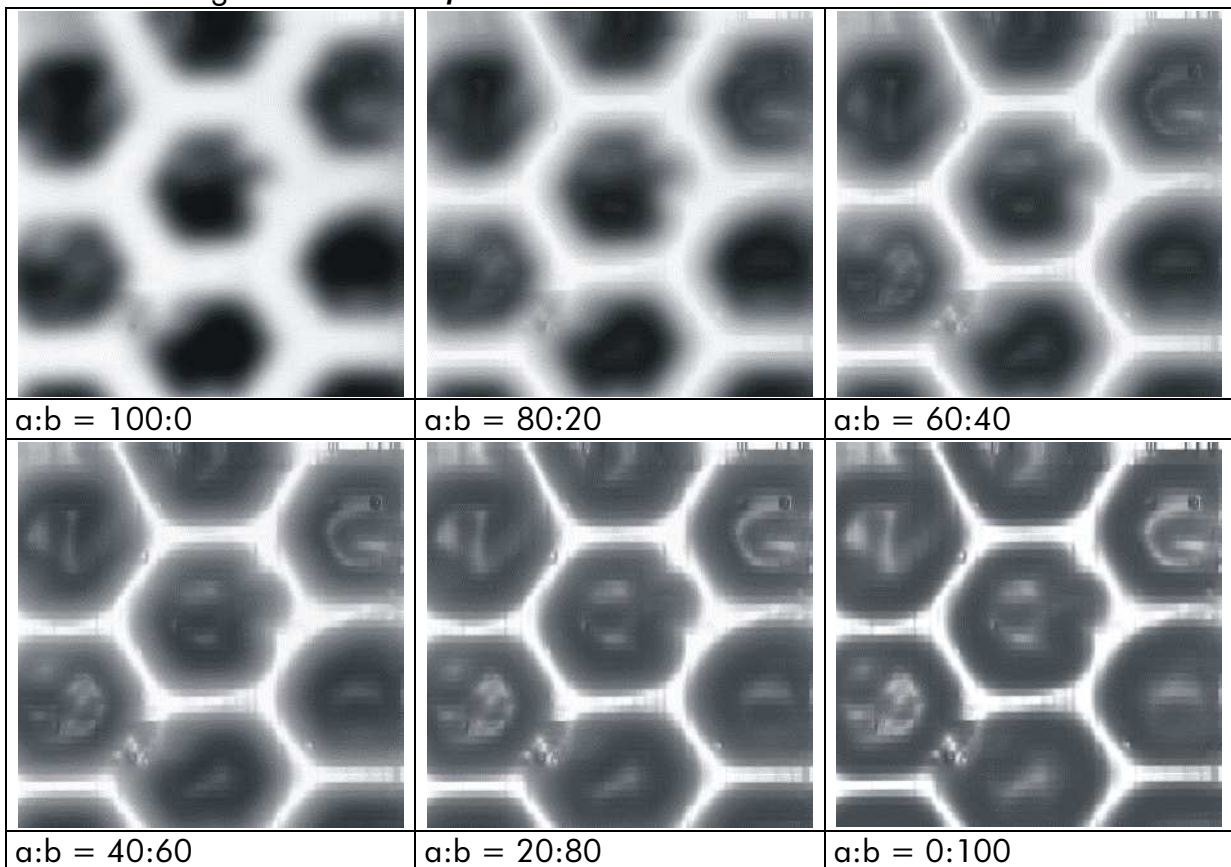

Fig. 55: Results of mixing height scale and diffuse reflection in different ratios a:b. a is the height-proportional shading, b in the image computed for diffuse reflection. Incident light comes from z direction.

### 3.4.10 Light source

Choose the direction of the light. Direction is given in  $(x, y, z)$  coordinates of the binary system. The example in the window indicates the light coming from the z direction (default). Incident light from the side tends to produce shades that highlight small features.

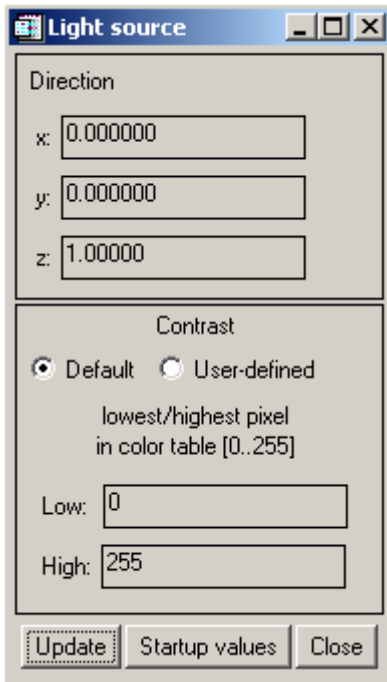

Fig. 56: Light source.

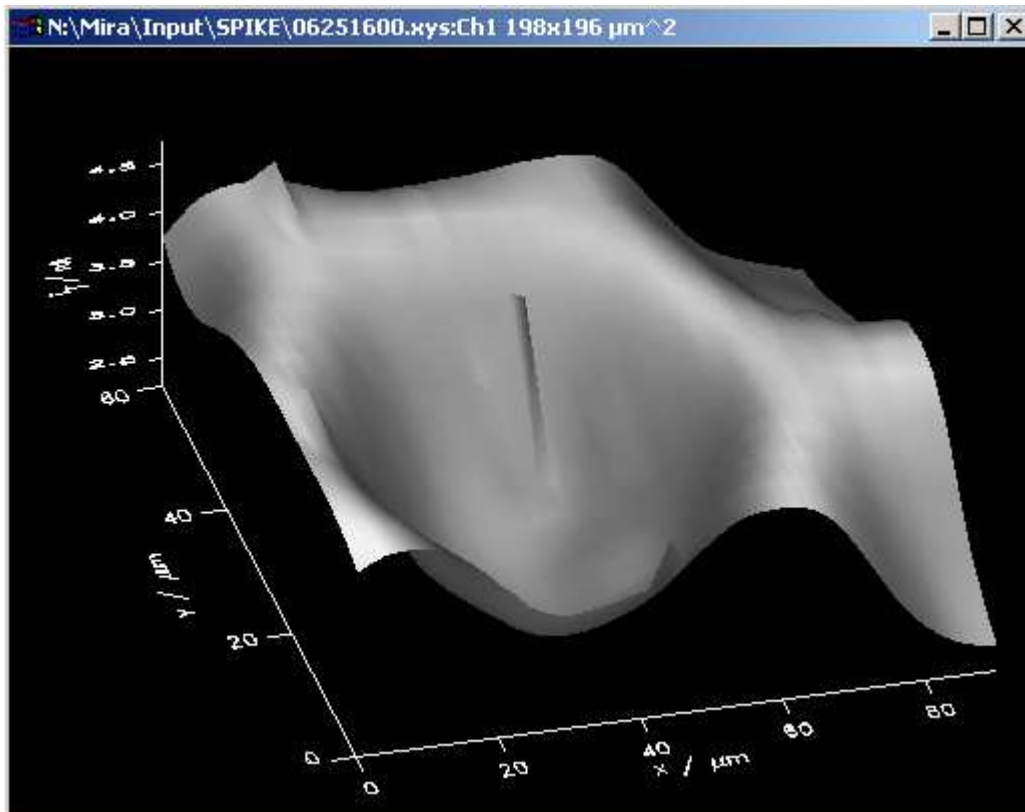

Fig. 57: Light source: Before changing the direction.

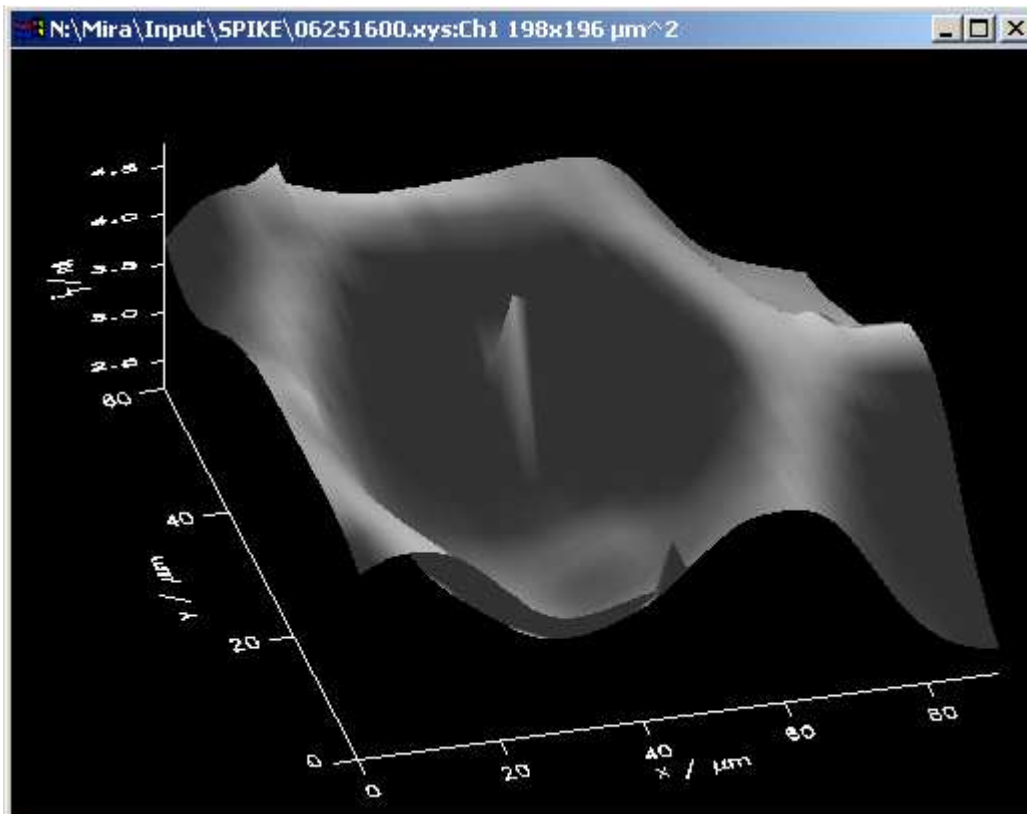

Fig. 58: Light source: After changing the direction off the vertical direction.

Figure 57 and figure 58 show the same plot. The only difference is the direction the light comes from. To point out a detail this functions allows to enlarge the contrast of an ambit without changing plot-internal parameters.

### 3.4.11 Symbol

If 2D plots are generated you can control the appearance of the individual data points in the window *Plot format/Symbol*. The current setting would draw a thin line only (default). In order to draw symbols select *Line and symbols* or *Symbols only* on the left side. The symbol itself is selected on the right side.

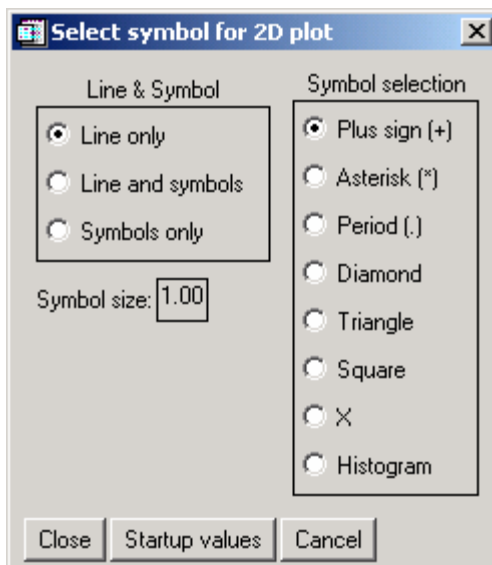

Fig. 59: Symbol.

### 3.4.12 2D Line Color

Sets the color for lines and symbols in 2D Plots. Than can be used to distinguish data sets in Combined Plots. A graphical selection tool opens with the color palette of the currently selected palette (Fig. 60). Working with line colors requires a fundamental understanding of the color system. MIRA works with the color tables provided by IDL. Each color tables consists of 256 color. The may be viewed with the tool XLOADCT (→*Single Plot: Tools/XLoadct*) In one plotting comand only colors from one color table ca be used. The color selection tool selects a color index within this table. The actual color may be different depending on the selected color table. (Using the same index with different color tables will usually produce different colors!) In addition white and black are inverted on some output devices or graphic file types. In order to avoid the difficulties with that., MIRA has predefined standard foreground and background colors that typically produce black liens on white background. **If you intend to use colors by index from a specific color table, you have to indicate that by checking the option below the color display!** Otherwise the selected color will be stored but not used.

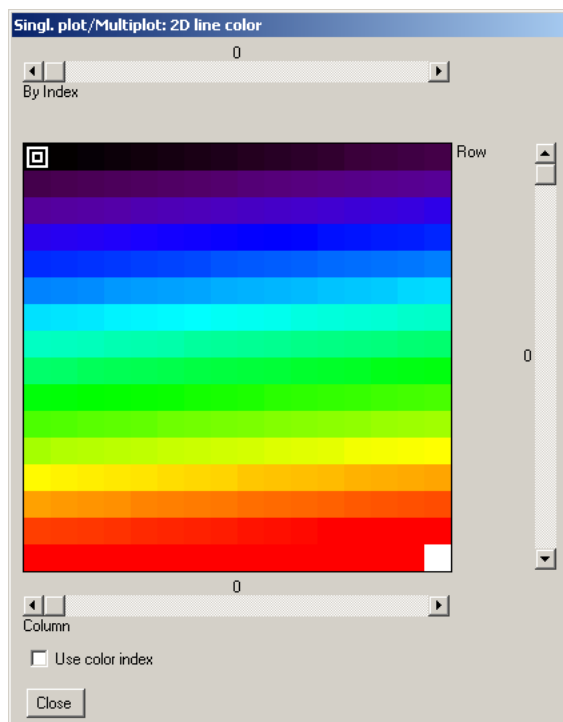

Fig. 60: Selection tool for line color.

### 3.4.13 Font System

Overview font system

There are three font system: i) **vector** fonts (the default), ii) **hardware** fonts (not recommended), and iii) **TrueType** fonts. Vector fonts give excellent quality when printed to PostScript files. Displays on the screen and in TIF and BMP files may leave wishes open. In this case you may either wish to increase the font size or change to TrueType fonts. TrueType fonts shall appear approximately equal on different file types. Hardware fonts are specific to certain output devices. It can not predicted how output

will appear on different devices. In particular formatting codes will not work in hardware fonts as well rotation of text lines.

The font system will be switched using the window under *Plot format/Font system*.

### Overview over font size

At several places of the program you may use to change the font size in the output. Although they all influence the final size of characters on the screen and on the printout, they should be used for a specific purpose.

### Menu Plot format/Font system in Single Plot

Here you should set the overall size of the characters and the distance between text lines. This will apply to all subsequent outputs of all graphic formats.

From *Multiplot* this menu is accessed via *Single Plot/Plot format/Font system*.

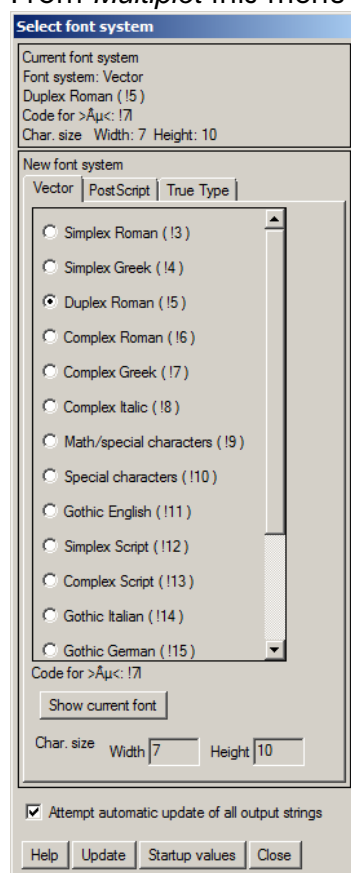

Fig. 61: Dialog for selection of the default font system.

You make all your selection on the right part of the form. The left part only gives information about the current status.

With the tab controls you select the font system (vector, hardware, TrueType). By the radio button you select a specific font within the above group as the default font (for instance Helvetica). The command button allows you to view the font of the currently selected radio button of the vector and TrueType tab. The following fonts are currently available.

Tab. 1: Available fonts



Command string	Vector font	Post Script font, i.e. example for hardware fonts	TruteType fonts
!3	Simplex Roman (default)	Helvetica	Helvetica
!4	Simplex Greek	Helvetica Bold	Helvetica Bold
!5	Duplex Roman	Helvetica Narrow	Helvetica Italic
!6	Complex Roman	Helvetica Narrow Bold Oblique	Helvetica Bold Italic
!7	Complex Greek	Times Roman	Times
!8	Complex Italic	Times Bold Italic	Times Italic
!9	Math/special characters	Symbol	Symbol
!M	Math/special characters (change effective for one character only)	Symbol	Symbol
!10	Special characters	Zapf Dingbats	Symbol *
!11	Gothic English	Courier	Courier
!12	Simplex Script	Courier Oblique	Courier Italic
!13	Complex Script	Palatino	Courier Bold
!14	Gothic Italian	Palatino Italic	Courier Bold Italic
!15	Gothic German	Palatino Bold	Times Bold
!16	Cyrillic	Palatino Bold Italic	Times Bold Italic
!17	Triplex Roman	Avant Garde Book	
!18	Triplex Italic	New Century Schoolbook	
!19		New Century Schoolbook Bold	
!20	Miscellaneous	Undefined User Font	
!X	Revert to the entry font	Revert to the entry font	Revert to the entry font

Known problems: No meaningful display is generated for the vector fonts Simplex Roman, Simplex Greek, Duplex Roman.

You can select the default font size and the line distance.

All your selection become only active if you press the command button *Update*. If the check box *Attempt automatic update of all output strings* is selected, MIRA will replace the the font selection switches (e.g. !5) in all output strings. The program will also search for all string segments that code for the substring "μ" in outputs. In the future more special characters can be replaced on demand. Meanwhile all other special character may require manually coding them with command strings. If the check box is not selected, only the font system will be changed but all switching codes will be untouched. You have to change them manually.

Note on character size. The size of a particular label will be determined by the combined action of three settings:

Char. size as Width and Height (in arbitrary units) given in the Font system settings (section 3.4.13)

Character size (section 3.1.7) given separately for each graphic format to adjust the different appearance of the same plot in different graphic file formats.

Character size factor (section 3.4.8) that adjusts the relative size between the labelling of the x, y and z axes.

### 3.4.14 Window size

Choose the size of the screen by changing the number of bits of x- and y-dimension of the screen window. The number of pixels of your screen is given to let you which portion of the screen would be covered by the window. If you are not satisfied with your selection you can go back to the startup values.

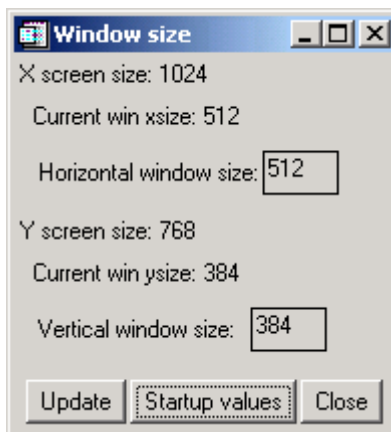

Fig. 62: Window size

### 3.4.15 Window title

To change the title of the graph window which appears after clicking the **<Redraw>** button. This function is useful if there is no high quality printer available and you want to make a copy of the screen to the clipboard to generate a BMP image.

For example:

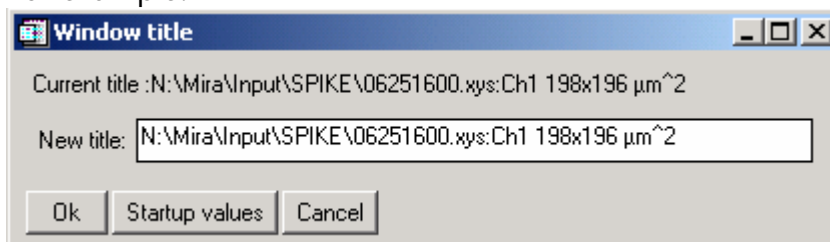

Fig. 63: Window title.

The standard title is the full file name of the data set and the dimensions. Changing the standard value may be helpful if you want to copy/paste a graphic window into another document (electronic lab journal). To copy the active graph window select the graph window and press *Alt + [Druck]* or *Alt + [Print]*. The particular key combination may depend on your Windows operating system settings (country, keyboard etc.)

### 3.5 Options +?

#### 3.5.1 Extended widget, Minimal Widget, Extended widget + infobox, Minimal widget + infobox

The general meaning of this term is explained in the introduction of *Single plot*. You can change the appearance of an existing Single plot widget with the menu options. The

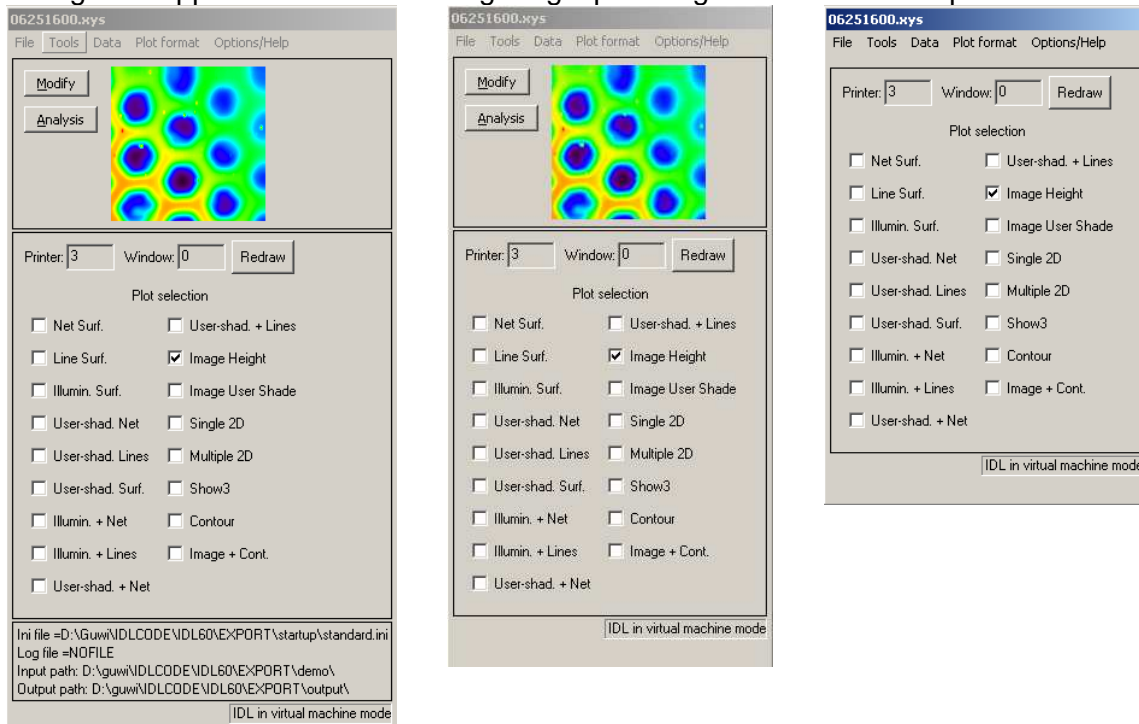

Fig. 64: Different layout of the Single plot widget from left to right: Extended + info box, Extended, Minimal (Minimal + info box is not shown).

#### 3.5.2 Load INI file

Usually you will select the desired initialization file in the main screen of the program (Fig. 10). If you want change the initialization file later, this option gives you the chance to do so. This may be useful if you have predefined settings for a certain filetype (such as color tables or different input path).

#### 3.5.3 Save INI file

A number of defaults can be set during the saving of an initialization file:

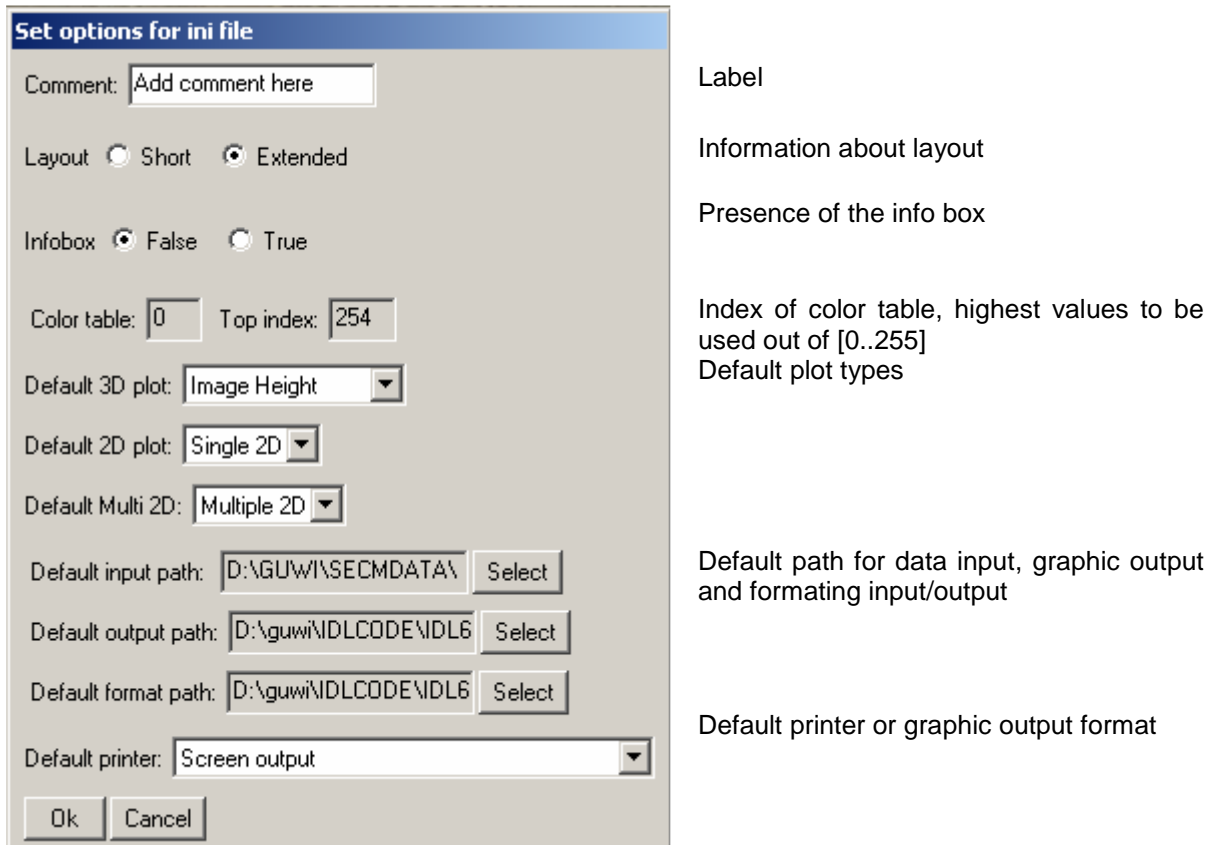

Fig. 65: Default options

### 3.5.4 Information about MIRA

This displays information about MIRA

### 3.5.5 What's new in MIRA VM xx

This displays recent changes to the MIRA software to direct experienced users to the things that might be different from the behavior of MIRA in the past,

### 3.5.6 Manual about MIRA

Displays this manual in Acrobat Reader.

### 3.5.7 RSI manual about iTools

This displays a manual about the iTools. This manual comes from RSI and Gunther Wittstock is not the author nor was the content checked for agreement with the program. Usually I found the RSI manuals quite helpful.

## 3.6 Plot selection

Select a plot out of the choices given in the main window of *Single Plot*. The following plot types are there by default. Most plots require a 3D data set. The color of line and background can be changed. Current default for all devices is black lines on white background.

### 3.6.1 Net Surf.

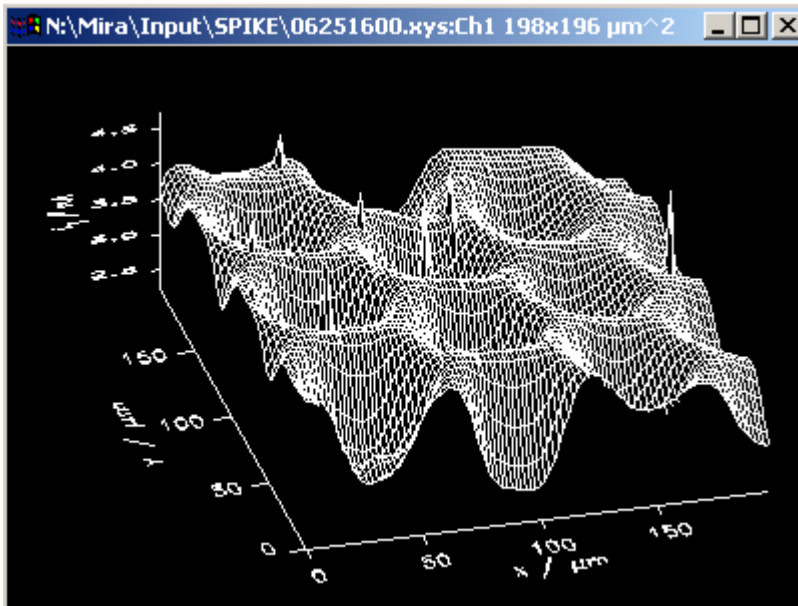

Net constructed surface

Fig. 66: Net surface

### 3.6.2 Line Surf.

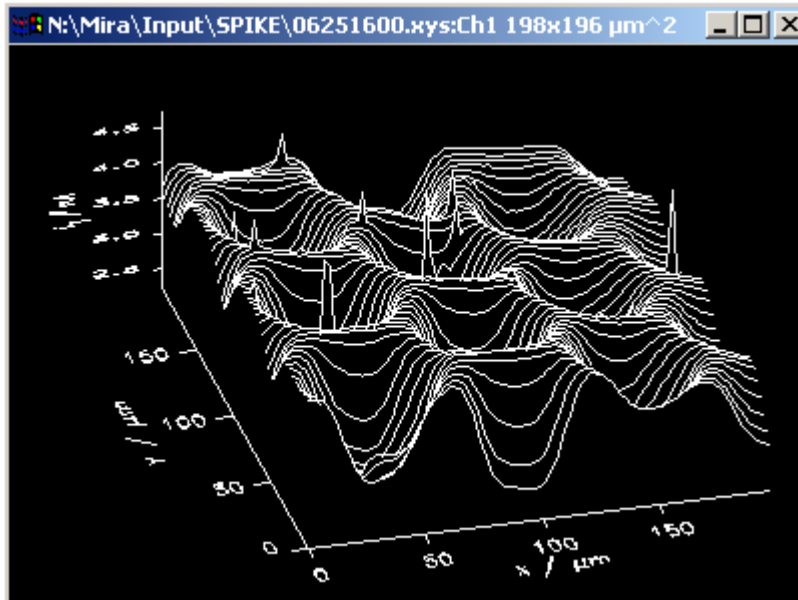

Line constructed surface

Fig. 67: Line surface

### 3.6.3 Illumin. Surf.

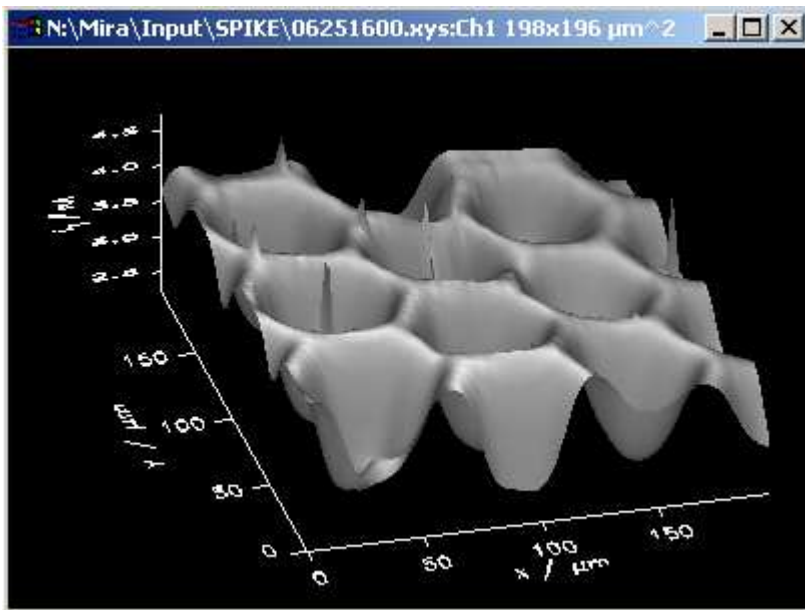

Fig. 68: Illuminated surface

This plot gets a pseudo 3D outlook because of being illuminated by one light source. The light direction can be set using *Plot format/Light source*

### 3.6.4 User-shad. Net

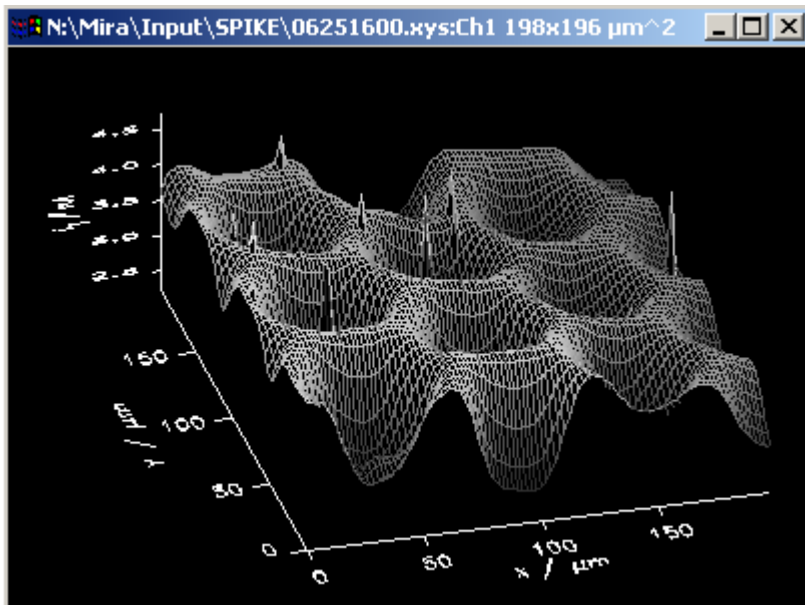

Fig. 69: User-shaded net

Net constructed surface, color of the net is given by the value of z-axis. It can be modified in the window *Plot Format/Scale user scale*. Colors are mapped in the user-selected color scale.

### 3.6.5 User-shad. Lines

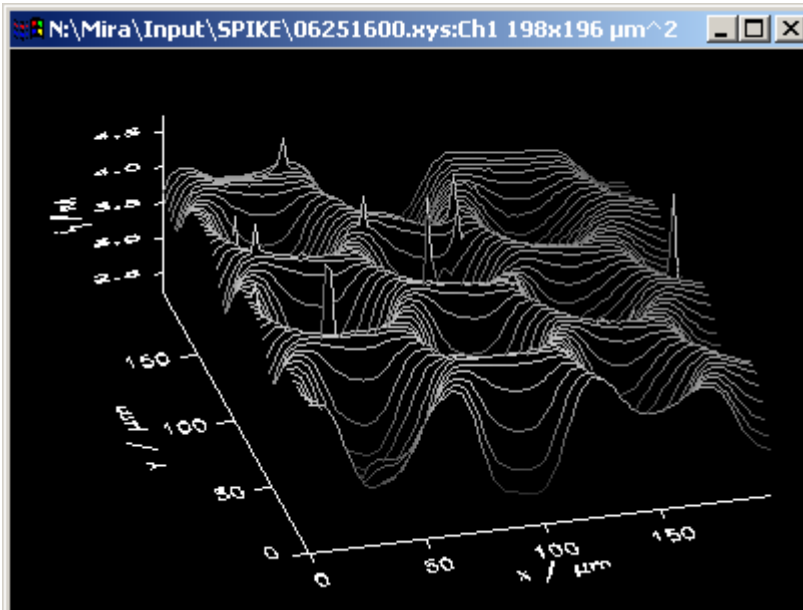

Fig. 70: User-shaded lines

Line constructed surface, color of the line is given by the value of z-axis. It can be modified in the window *Plot Format/Scale user scale*. Colors are mapped in the user-selected color scale.

### 3.6.6 User-shad. Surf.

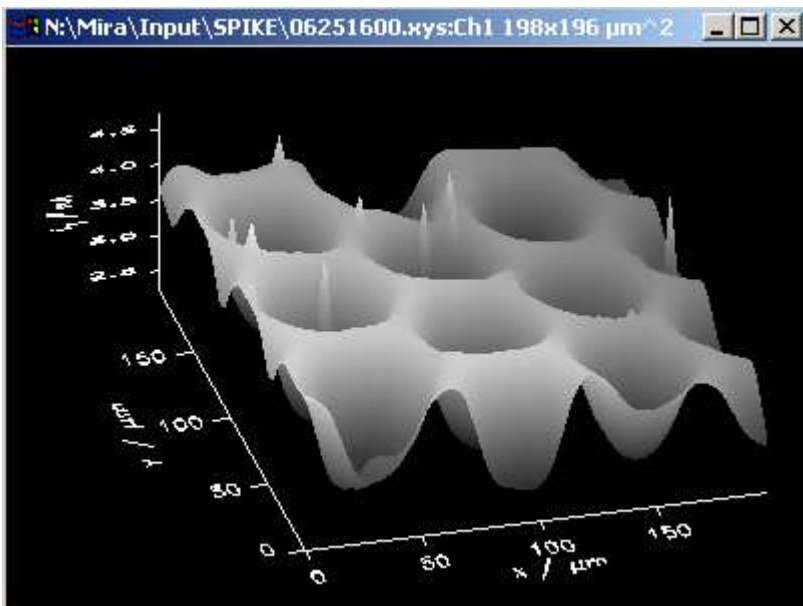

Fig. 71: User-shaded surface

Color of every pixel is given by the value of z-axis. It can be modified in the window *Plot Format/Scale user scale*. Colors are mapped in the user-selected color scale.

### 3.6.7 Illumin. + Net

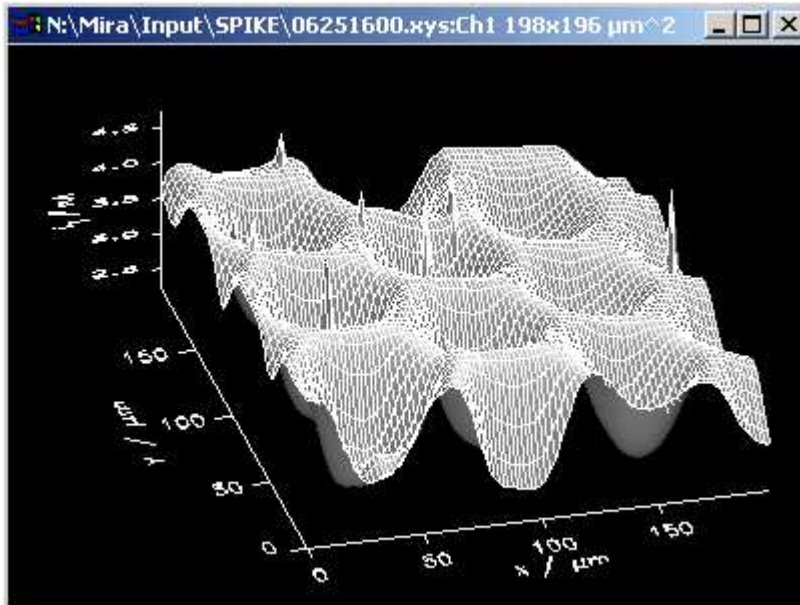

Fig. 72: Illuminated and net

Overlay of monochrome net on an illuminated surface.

### 3.6.8 Illumin. + Lines

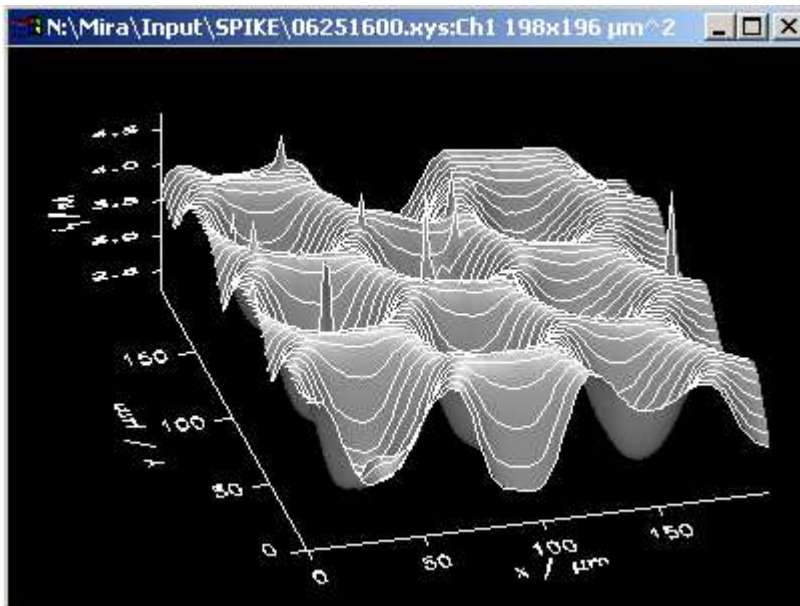

Fig. 73: Illuminated and lines

Overlay of monochrome net on illuminated surface.



### 3.6.9 User-shad. + Net

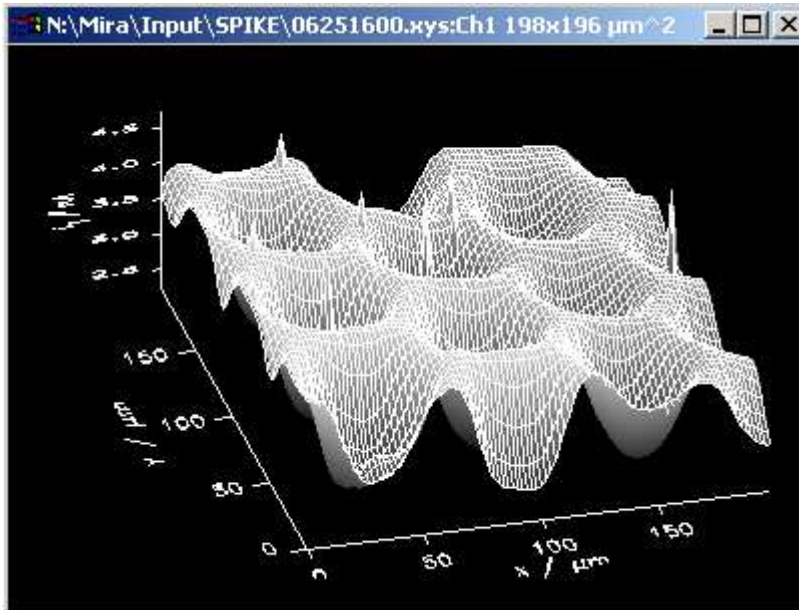

Fig. 74: User-shaded and net

Overlay of a net construction (monochrome) on a surface for which every pixel is given by the value of z-axis. The shading can be modified in the window *Plot Format /Scale user scale*.

### 3.6.10 User-shad. + Lines

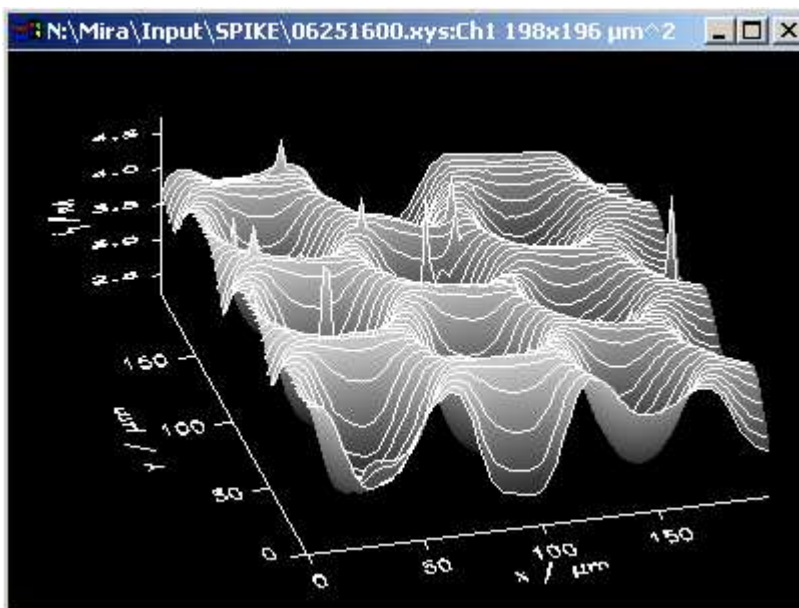
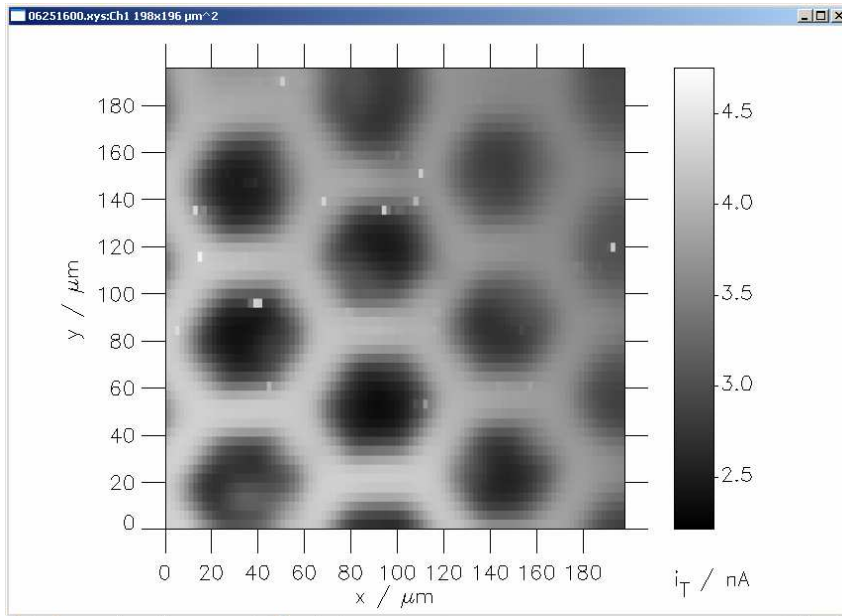

Fig. 75: User-shaded and lines

Overlay of a line construction (monochrome) on a surface for which every pixel is given by the value of z-axis. It can be modified in the window *Plot Format/Scale user scale*.

### 3.6.11 Image Height



2D graphic, current differences are pointed out by using different shades out of the color table. On the right there is a false color scale to indicate the value for which the shade stands for.

The current values look pixelated because they are not interpolated-

Fig. 76 Image Height (not interpolated)

### 3.6.12 Interpolated Image Height

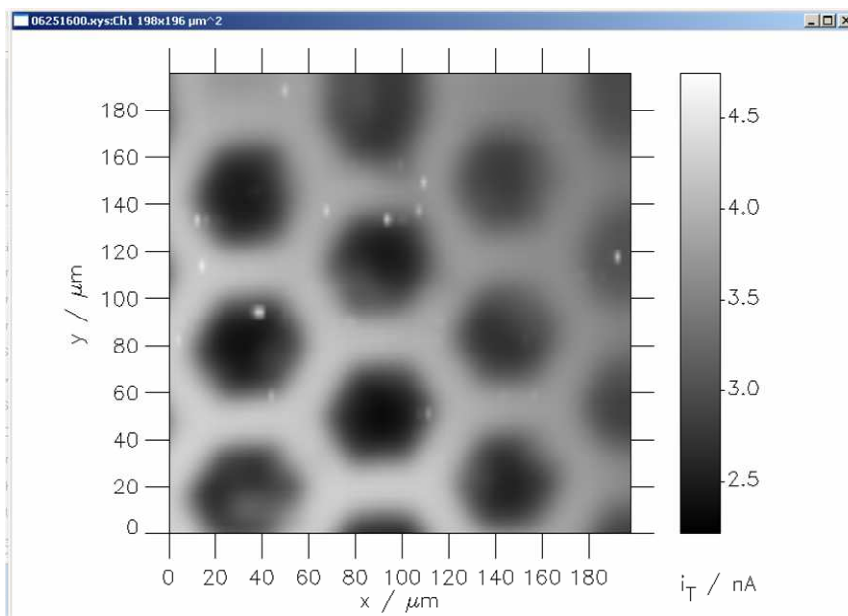

2D graphic, current differences are pointed out by using different shades out of the color table. On the right there is a false color scale to indicate the value for which the shade stands for.

The dataset looks smooth because the gray scale values are interpolated.

Fig.: 77 Interpolated Image height

### 3.6.13 Image User Shade

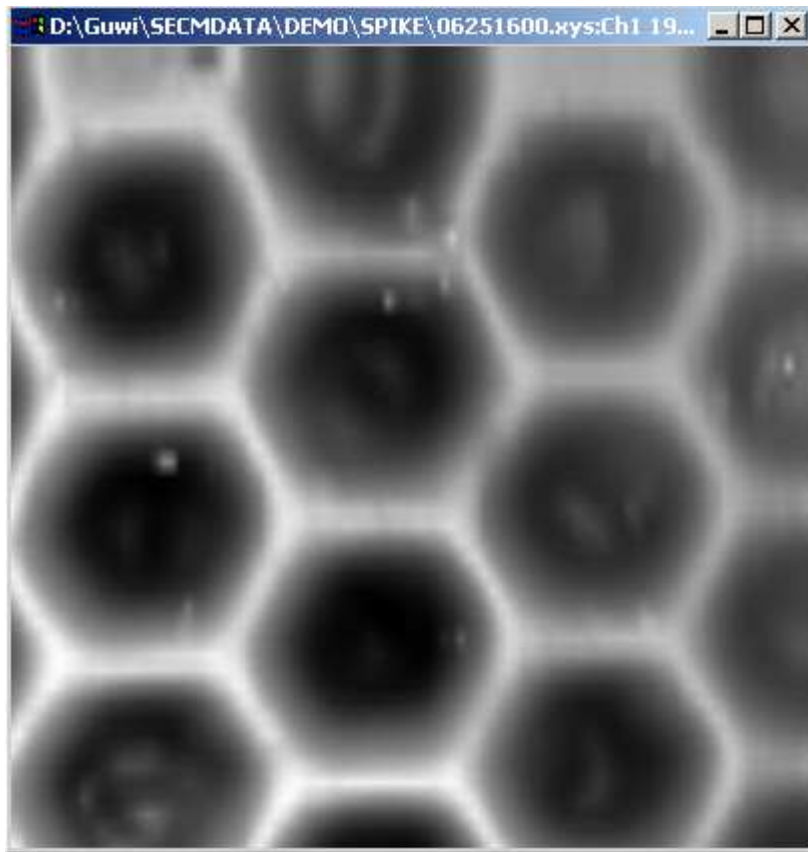

2D graphic, altitude differences are pointed out by using different shades out of the color table. In contrast to *Image Height*, it can be modified in the window *Plot Format/Scale user scale*.

Fig. 78: Image user shade

### 3.6.14 Single 2D

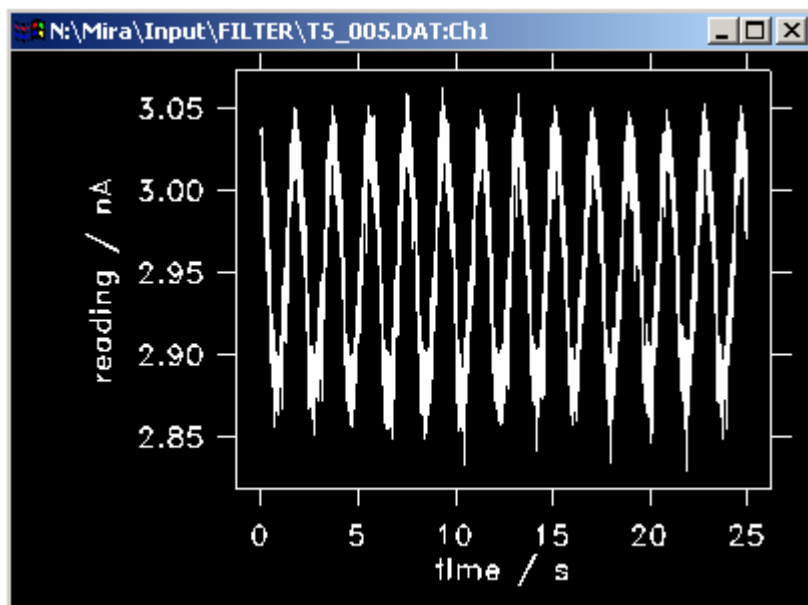

2D axis plot is possible only for (x,y) data sets like time series, cyclic voltammograms etc.

Fig. 79: Single 2D

### 3.6.15 Multiple 3D

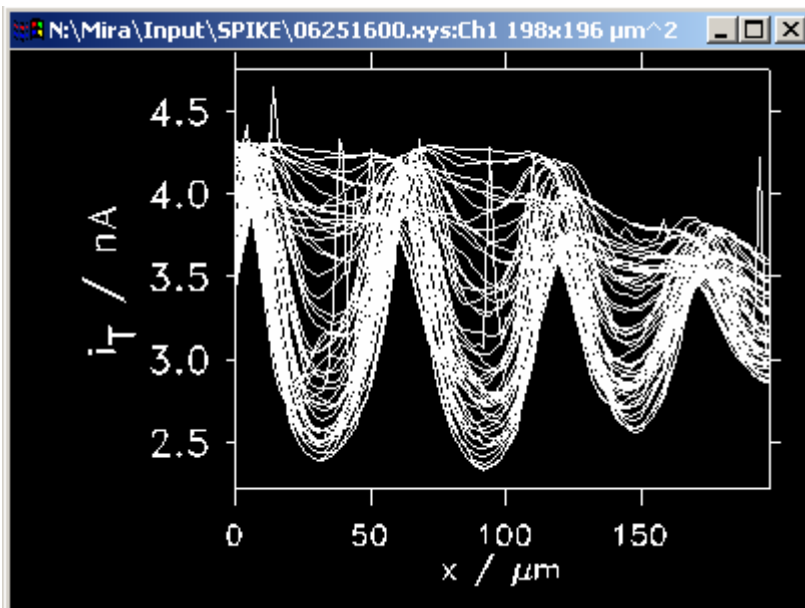

Fig. 80: Multiple 3D

This plot is usable for data sets containing two or three variables.

If there is a third variable the plot will be a stacked and overlaid plot of (x,z) data sets. For each value of y there will be one 2D plot. As a result you get as many curves as there are different y values.

### 3.6.16 Show3

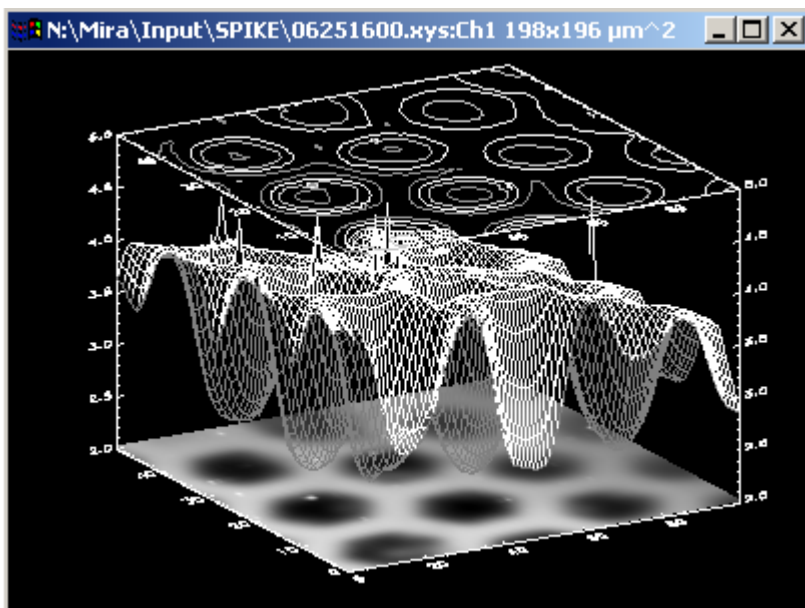

Fig. 81: Show3

Plot which is composed of three different data representation in one axis system.

On the bottom there is a 2D graphic in which a false color height-proportional image.

Additionally a 3D monochrome net is given and on the top there is a contour plot.

### 3.6.17 Contour

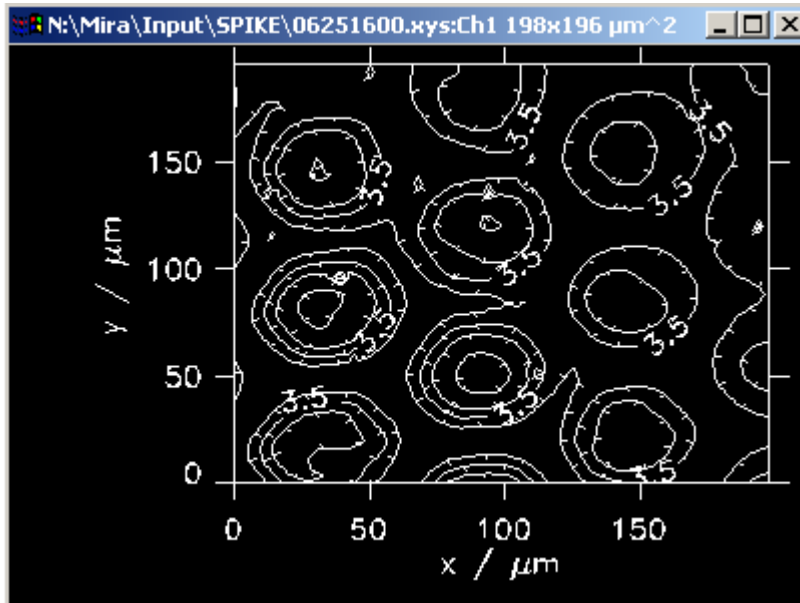

2D plot in which data values are indicated by contour lines of the plot connecting image points with the same height. Ticks show direction of increasing altitude.

Fig. 82: Contour

### 3.6.18 Image + Cont.

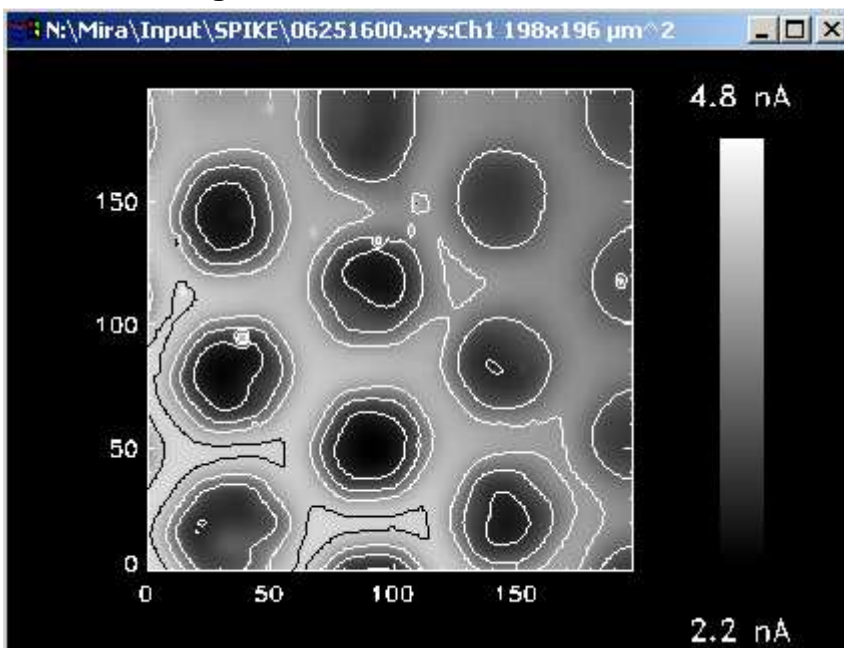

Overlay of a height scale image and a contour plot.

Fig. 83: Image and contour

#### Redraw

Each selected type of diagram will be presented in a separate graph window. If several graphs are selected, they will be placed in separate graph windows. If you want to compare different data sets plot the first data set in window 0. Change the entry into the window field to 1. Load the next data set and press redraw. Both data sets are now in different graph windows. However, the plot for the first data set cannot be changed. Alternatively you can load both data sets to *Multiplot* and switch between manipulating both data sets (recommended).

The following options are only available if you choose extended layout.

## 3.7 Modify

All these routines will make changes to the data itself rather than to format the corresponding graphs. Therefore a warning will appear before going to the actual windows. There is no undo function. In order to undo, you have to re-load the data set.

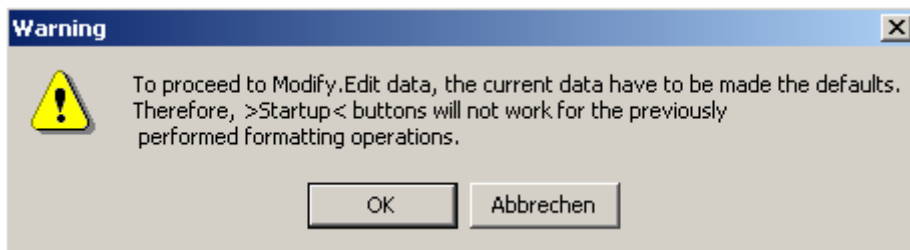

Fig. 84: Warning of flattening.

### 3.7.1 Linear flatten

If your plot plane has a tilt, you can subtract it from the data set itself. See the difference to

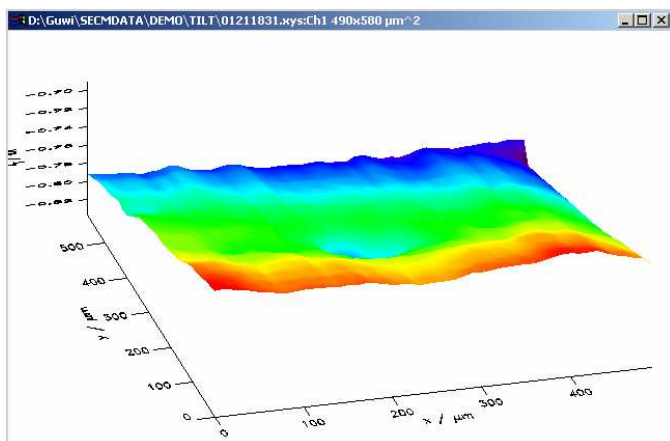

Fig. 85: Plot with tilted background.

As you can see in this graphic, the complete area looks inclined. In order to focus the view on the feature in the middle, you can subtract from each image line a value to align the image in one plane but to preserve height variations. In contrast to *Plot format/Scale user shade*, the changes is done on the data set itself. This is a common practice in AFM height measurements.

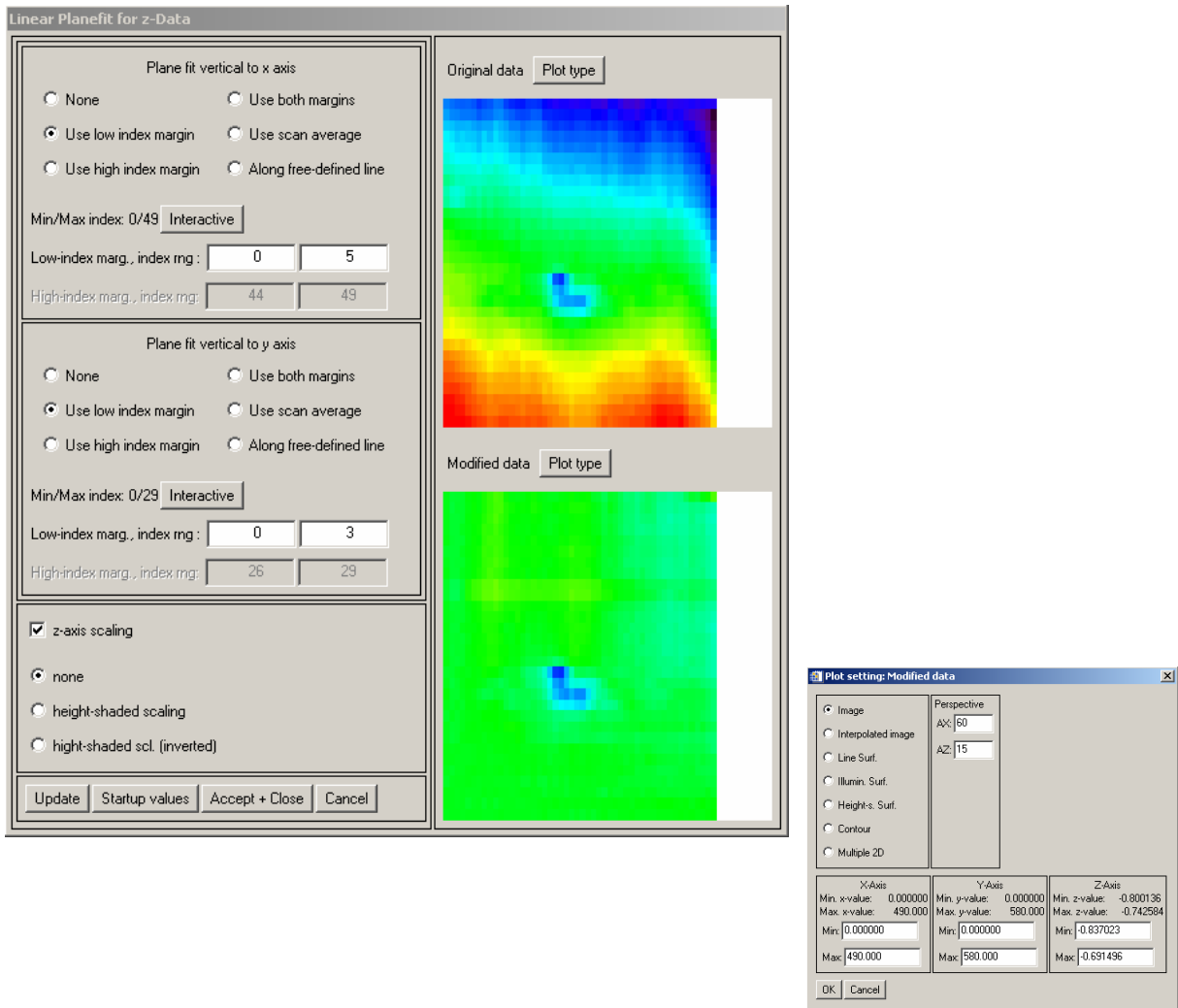

Fig. 86: Linear flatten, main screen. The display of original and modified data can be selected in the right window.



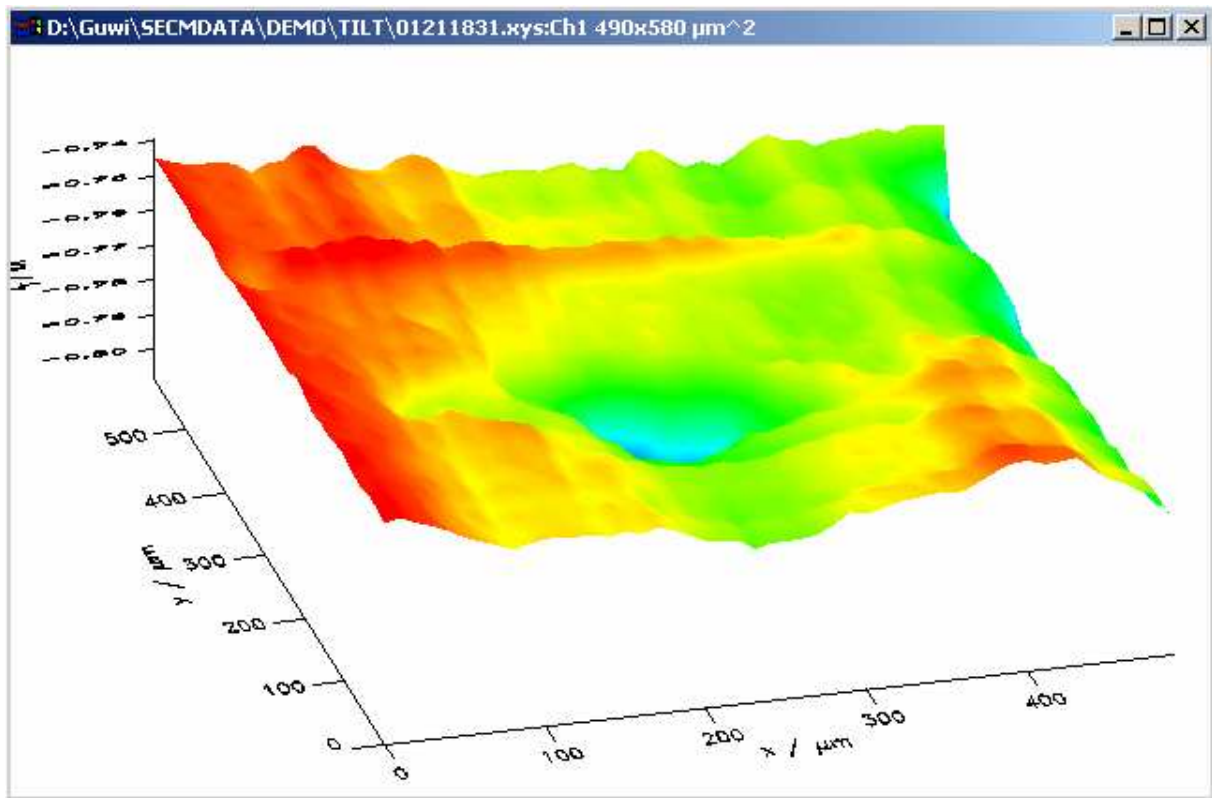

Fig. 87: Plot after leveling.

Figure 87 shows the plot after setting the line average as described in the Window of Fig. 86 to a unified value. The height differences within a scan are still o.k. The absolute current values have changed substantially.

### 3.7.2 Polynom flatten

Another algorithm to flatten your data than the one described in 3.7.1 is to subtract a polynom that was calculated as the best fit to your data. You can select the order of the polynom [0...11]. Zero order will subtract a constant, 1 will be a tilted plane and so forth. High polynom orders only seldom make sense. The form shows you the original data, the calculated background and the resulting data. You can select different plot representations under the *Plot* menu. To accept the changes to the data it self, select *Data/Accept changes* and then *File/Close*. To exit without changes select *File/Cancel*. The option button "Retain mean value" will ensure that not just the difference between background and data value will be returned but that the mean of the returned array is equal to the mean value of the input data.

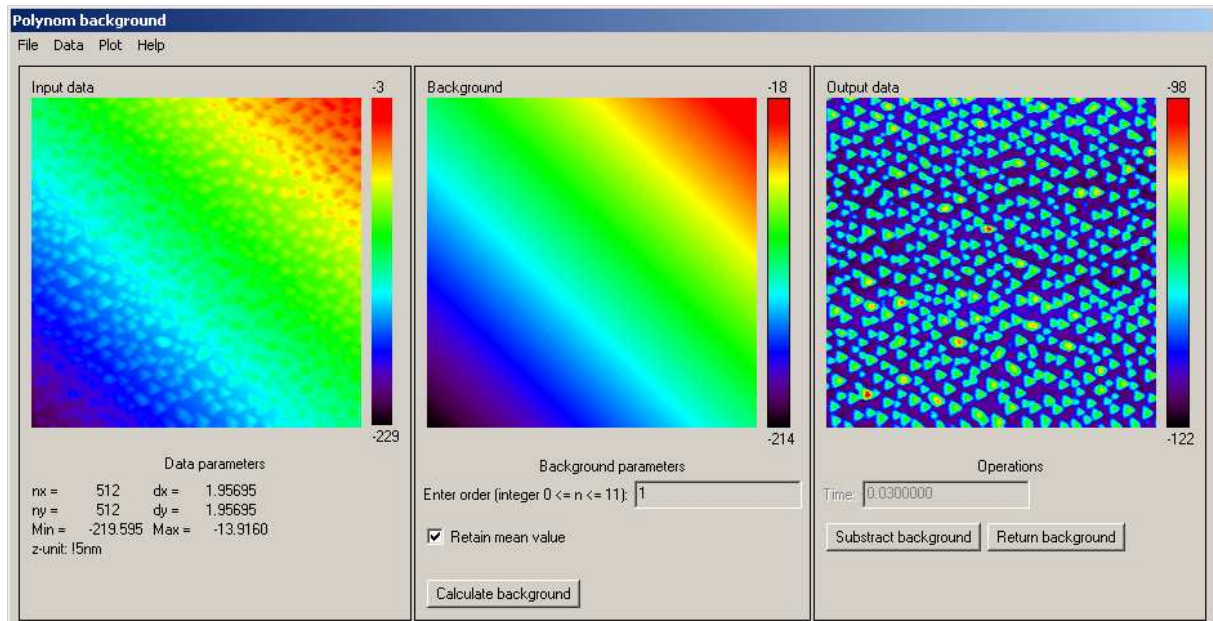

Fig 88: Window for polynom flatten. The operation is applied to the data itself.

### 3.7.3 Rolling sphere flatten

If the background cannot be described by a polynom or if line-by-line flatten does not yield the desired result (artifacts) the background can be calculated by the path a sphere of a defined radius would roll below or above the surface. This is illustrated in Fig. 89.

The window to start this option is similar to the other modify windows (Fig. 90). The filter radius determines from which change in z values is considered to be background. Only signals with considerable smaller radius than the calculated sphere will not be removed. The z-zoom-factor will be multiplied with the data. After the background subtraction the resulting array will be divided by the z-zoom factor. The option above/below determine whether small depressions or small elevations will be highlighted. If you want to highlight small depression you must roll the sphere above the data. If you want to emphasize small elevation you should roll the sphere below the data (as shown in Fig. 89). You can select different plot representations under the *Plot* menu. To accept the changes to the data itself, select *Data/Accept changes* and then *File/Close*. To exit without changes select *File/Cancel*. The option button "Retain mean value" will ensure that not just the difference between background and data value will be returned but that the mean of the returned array is equal to the mean value of the input data.

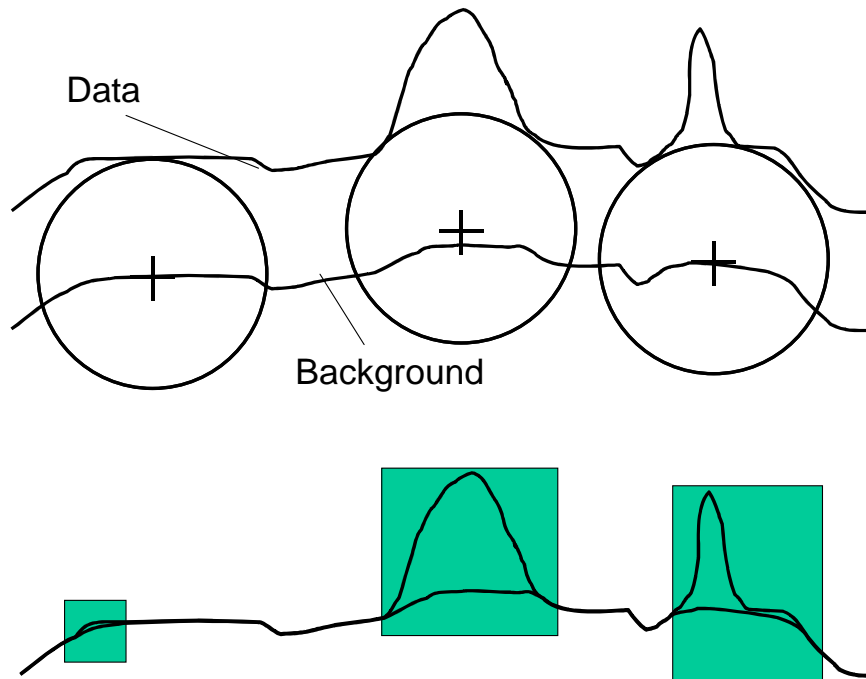

Fig. 89: Principle of the background calculation by the path of a rolling sphere.

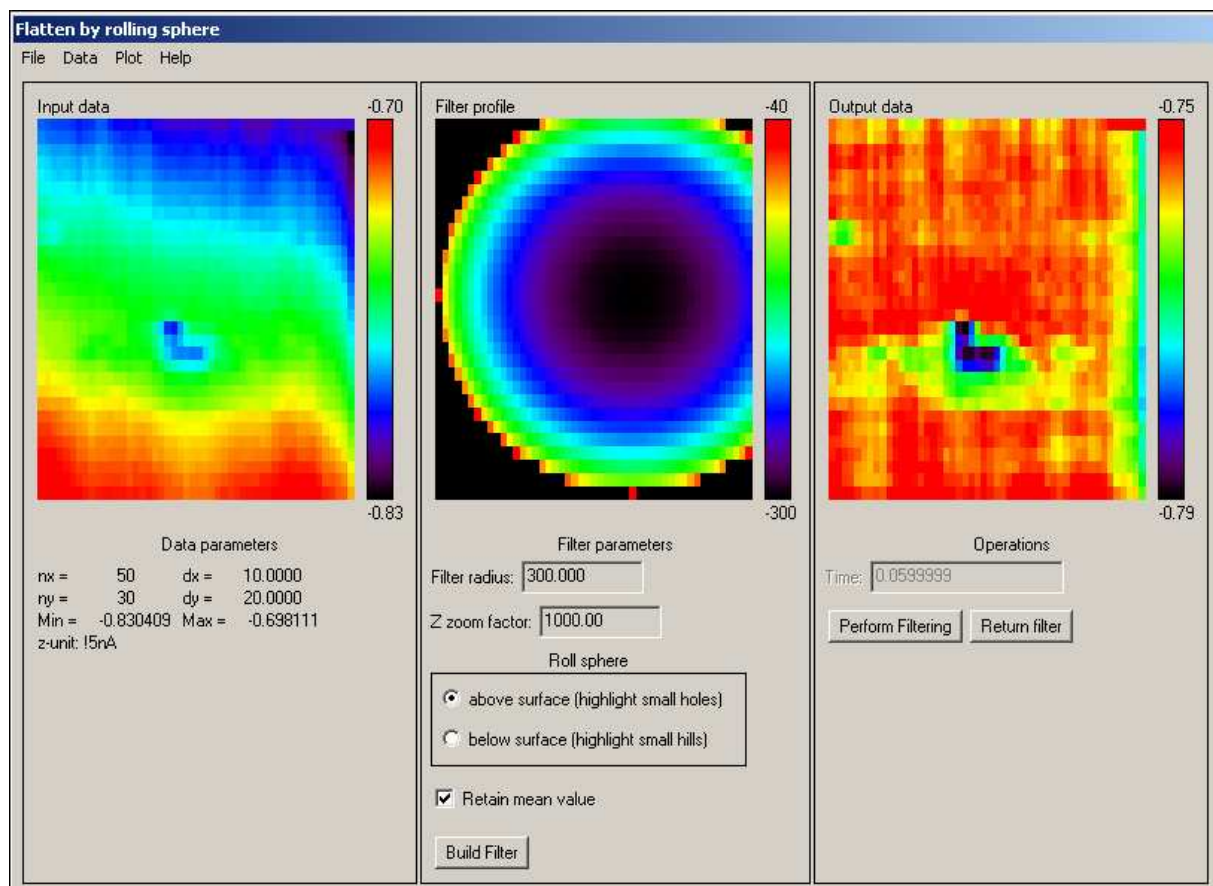

Fig. 90: Principle of the background calculation by the path of a rolling sphere.

### 3.7.4 Spike removal

Spike in SECM images may occur do to electromagnetic interferences or temporal mechanical collision of the probe and the sample. These signals usually are smaller

than a signal can be then imaged with a probe of finite size. This can be used to identify points that might be influenced by such phenomena.

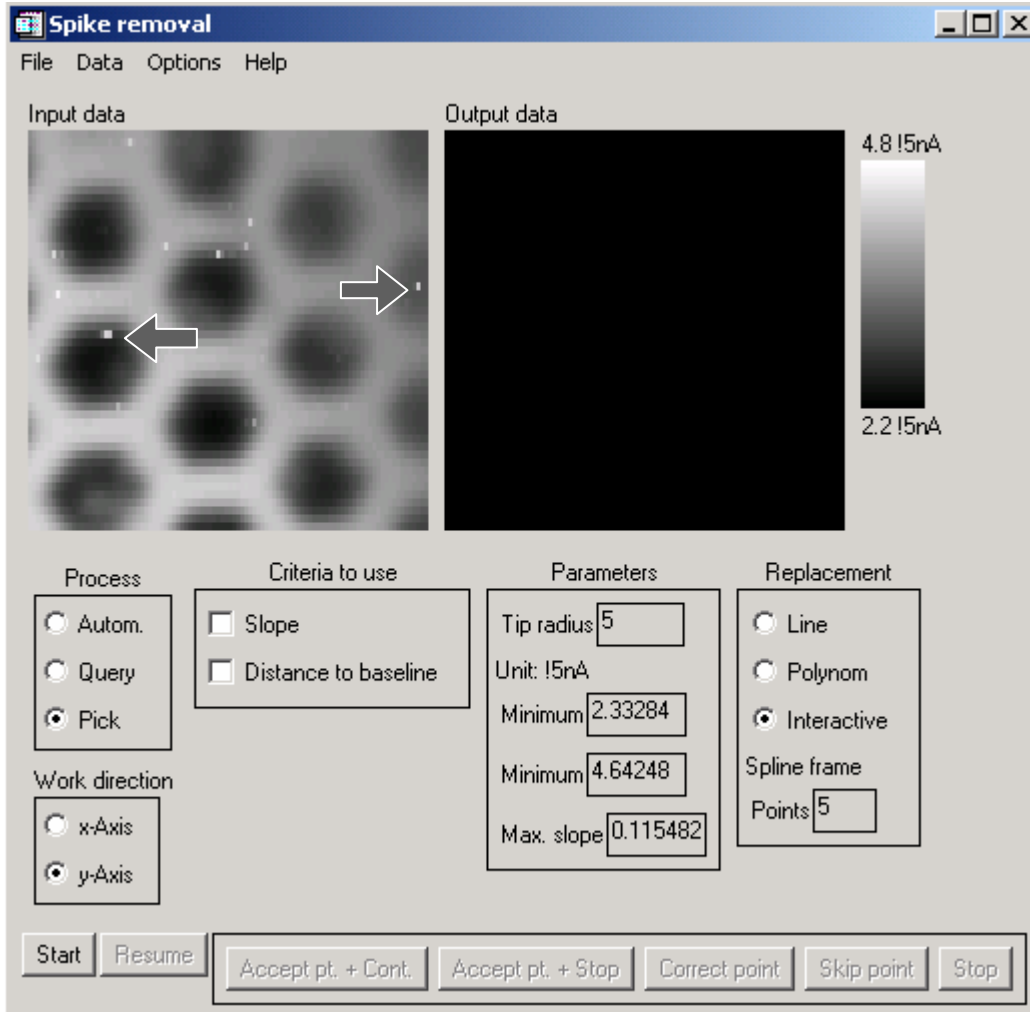

Fig. 91:Data set input.

As you can see in the Input data window (Fig. 91) there are some spikes (white). With help of the value for the tip radius as an input parameter, this function will identify data that might be a spike. You can also manually select them. After choosing the wanted configuration press **<start>**.

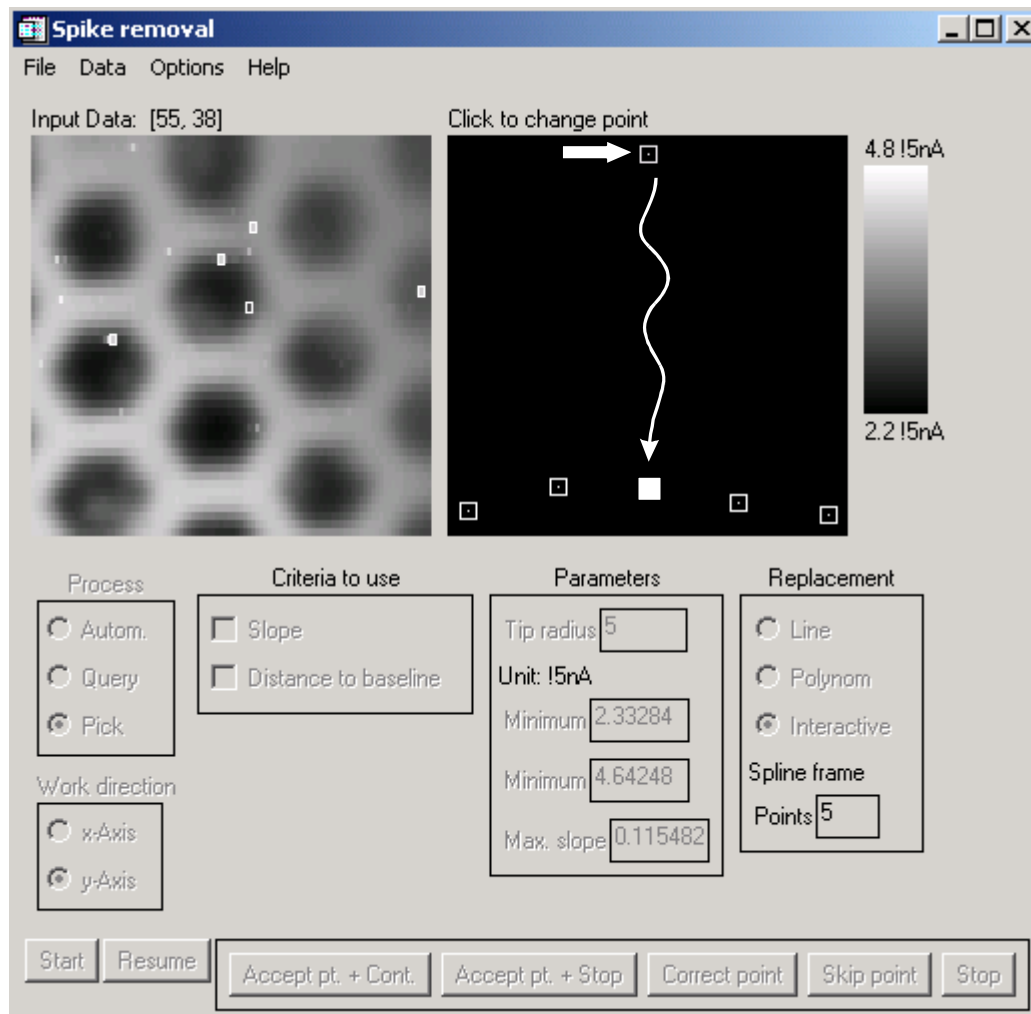

Fig. 92: Data set after marking.

Afterwards possible spikes are identified either manually or automatically. The point together with the neighboring data points are shown in the right. Select a position for the modified position of the suspected spike either by clicking on it or by linear or polynomial interpolation. For optimum performance use work directions (x, y) after another. After completing one work direction confirm changes *Data/Accept changes*.

This routine can be automatized in several steps. Instead of you selecting suspected points this can be made by the program (Options *Autom.* and *Query* under *Process*, left). The replacement can than be done either by hand or by fitting a line or a polynom through the neighboring data points.

The right image displays the modified data set. If you are satisfied, modify the working data set under *Data/Accept changes*. You may then consider to further working on the data set (e.g. along the y-Axis). After finishing with one setting you should used *Data/Accept changes*. To return to the *Single Plot* option use *Data/Accept changes* and *File/Exit* and confirm once again the changes.

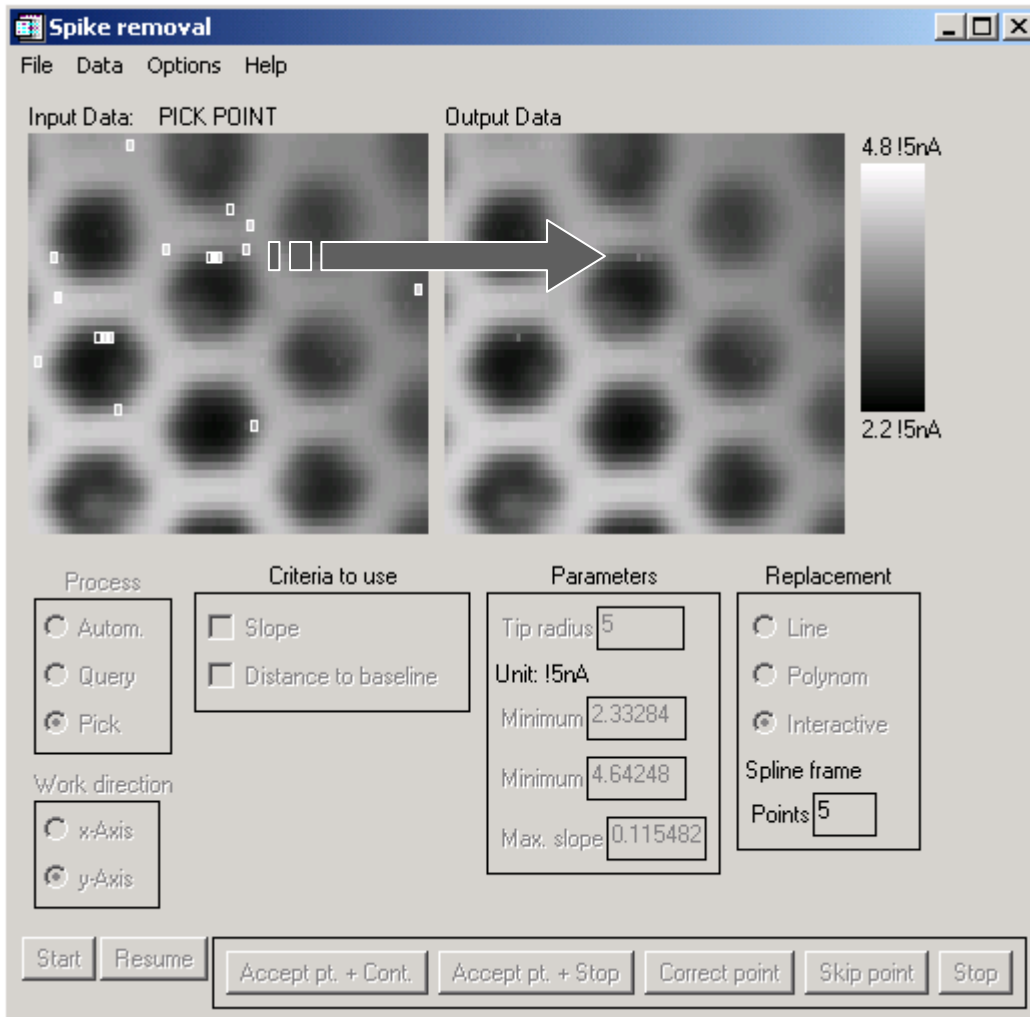

Fig. 93: Output data in comparison with Input data.

Figure 93 shows both data sets: The input set and the output set.

### 3.7.5 Advanced Spike Removal

Advanced spike removal works essentially the same way as Spike Removal (see previous section). It has an added feature to enlarge a subsection of the input data and show it in an additional display. This is helpful, if the image contains many data points and placing the cursor accurately may not be easy. In even larger images not all points may be on display. When points are picked manually, the selection must be made in the middle image.

Automatic selection work on the left display of input data (i.e. NOT only on the zoomed subsection).

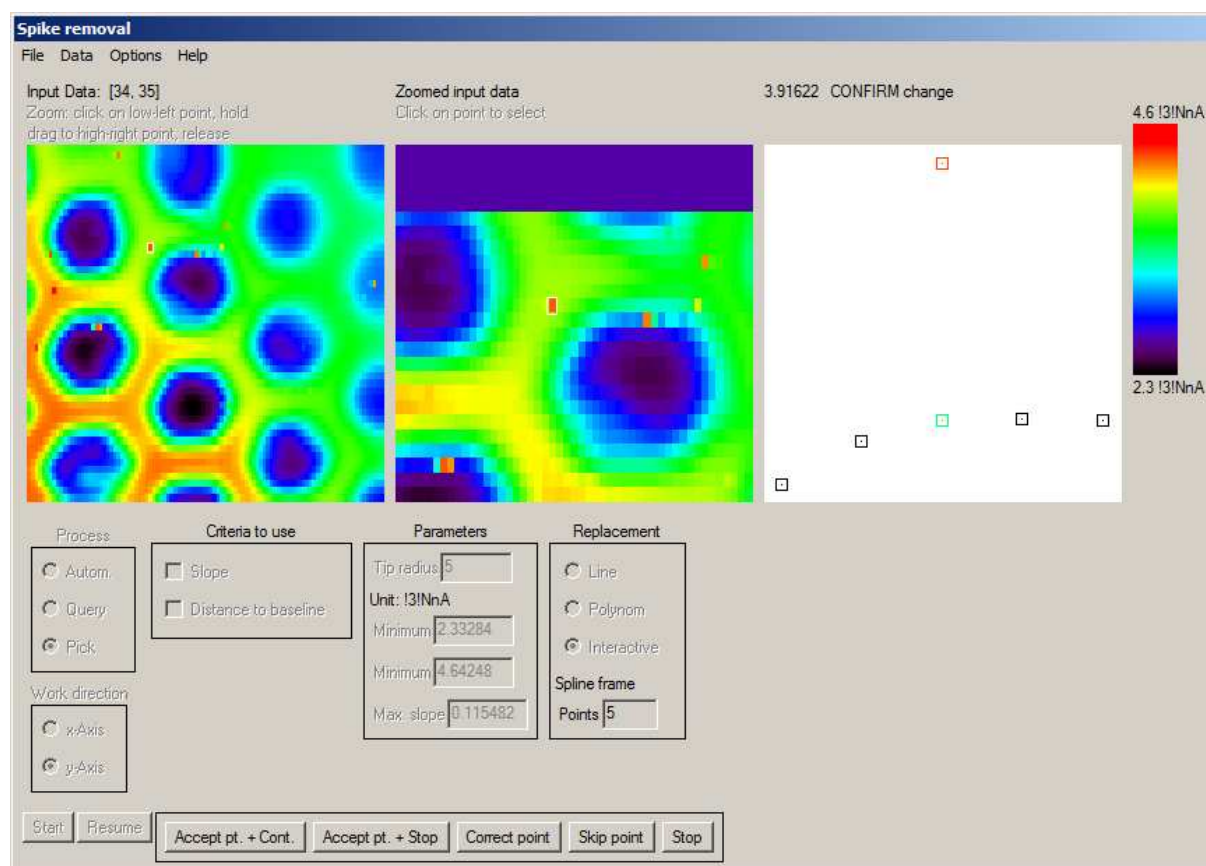

Fig. 94: Window for Advanced Spike Removal. The middle image shows an enlarged section of the input data.

### 3.7.6 SECM deblurring/edge enhancement

This filter restores the image by subtracting the diffusional blurring from the measured image. It is useful for SECM data. The filter is described in C. Lee, D.O. Wipf, A.J. Bard, K. Bartels, A.C. Bovik; *Anal. Chem.* **1991**, 63, 2442-2447. It has some serious disadvantages: i) the edge has to be discarded, depending on the size of the filter. ii) reasonable results are obtained only if the density of points in x and y direction is equal. While the parameter sigma of the filter is correlated to the radius,  $\tau$  can be set arbitrarily. We found that this routine extremely seldom gives acceptable results and a modification of the shading by mixing a height-shaded image and one calculated based on diffuse reflection as described under Plot Format/Scale user shade give often better results without the disadvantages of this procedure. Details are described in G. Wittstock, T. Asmus, T. Wilhelm; Investigation of Ion-Bombarded Conducting Polymer Films by Scanning Electrochemical Microscopy (SECM). *Fresenius J. Anal. Chem.* **2000**, 367, 346-351.

In order to operate the window, set the parameters for the filter based on the information shown under the input data on the left, press <**Build Filter**> and then <**Deblur**>. The filter is displayed in the middle and the result in the right window. The plot type for showing input data, filter and output data can be modified under *Plot/Input*, *Plot/Filter* and *Plot/Output* as described in Fig. 86, right.

Instead of the modified data set, the filter can be returned to single plot when using <**Return Filter**> and *File/Close*.

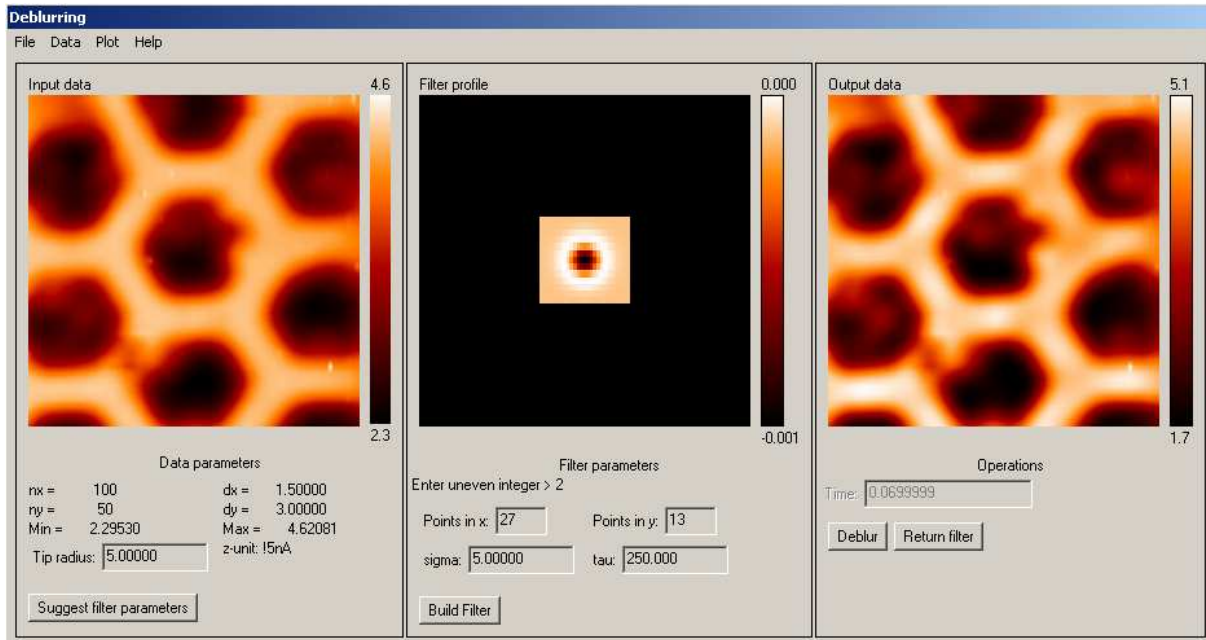

Fig. 95: Window for performing the deblur operation.

### 3.7.7 Adjust bundle setting

"Bundle" is the term used for electrodes (sensors) that are measured simultaneously by a multipotentiostat, typically in a multi-tip scanning probe microscope. The tips may not be of the same sensitivity (for instance due to slight variations in their size). They may also have a positional offset on the sample. MIRA reconstructs the image from the measured data and correction values. The following corrections are used

**x position offset** *xoffset*.  $xoffset[i] = 0$  means the *i*-th electrode has the same x coordinate as positioning system

**y position offset** *yoffset*.  $yoffset[i] = 0$  means that electrode *i* has the same y coordinate as the positioning system.

**z value offset** *zoffset*.  $zoffset[i] = 0$  means that no offset correction is applied to the values coming from sensor *i*.

**correction factor of the sensitivity scale factor**.  $scalefactor[i] = 1.0$  means no correction is applied for electrode *i*.

The *Adjust bundle setting* form allows editing the correction values and the measured values itself.

The corrected values are obtained as

$$x_{i,corr} = x_i + xoffset[i] \tag{1}$$

$$y_{i,corr} = y_i + yoffset[i] \tag{2}$$

$$z_{i,corr} = (z_i - zoffset[i]) * scalefactor[i] \tag{3}$$

The data are placed in three tables on a tab form. The tab *Conversion values* contains the *xoffset*, *yoffset*, *zoffset* and *scale factor* for each electrode (sensor) of the bundle. In order to allow more precise correction all data from a certain sensor or all data from a sensor and a spcified scan can be displayed in a different color (all scans from sensor #5 in Fig. 96)

The tab *Tab data* contains the tabulated data for x, y, and z data.

The tab *Use values* allows to exclude and include/exclude data from an individual sensor or a particular line scan from all sensors.



In order to edit the data, click on the cell, type the new value and press **[Enter]**. Without **[Enter]** the new value will not be copied into the table. Changing the value in the table, does not lead to an immediate change of the data itself. You have to press **<Update>** to make the change effective in the *Adjust bundle setting* form. The edited data will be displayed on the right side as multi 2D-plot showing the lines recorded for each sensor in an overlaid plot. If the data can be processed to an image, the image is displayed in the upper graph. The crosses which can be displayed under *Display/Show point location* mark the positions of the provided data (tabulated x and y data with corrections) from which the interpolation of all other points was performed. The color of the crosses is white if the false color on the scale 0...255 is below 205 and black if it equal or larger than 205. The current scales give the min-max values of the data set after applying the correction values.

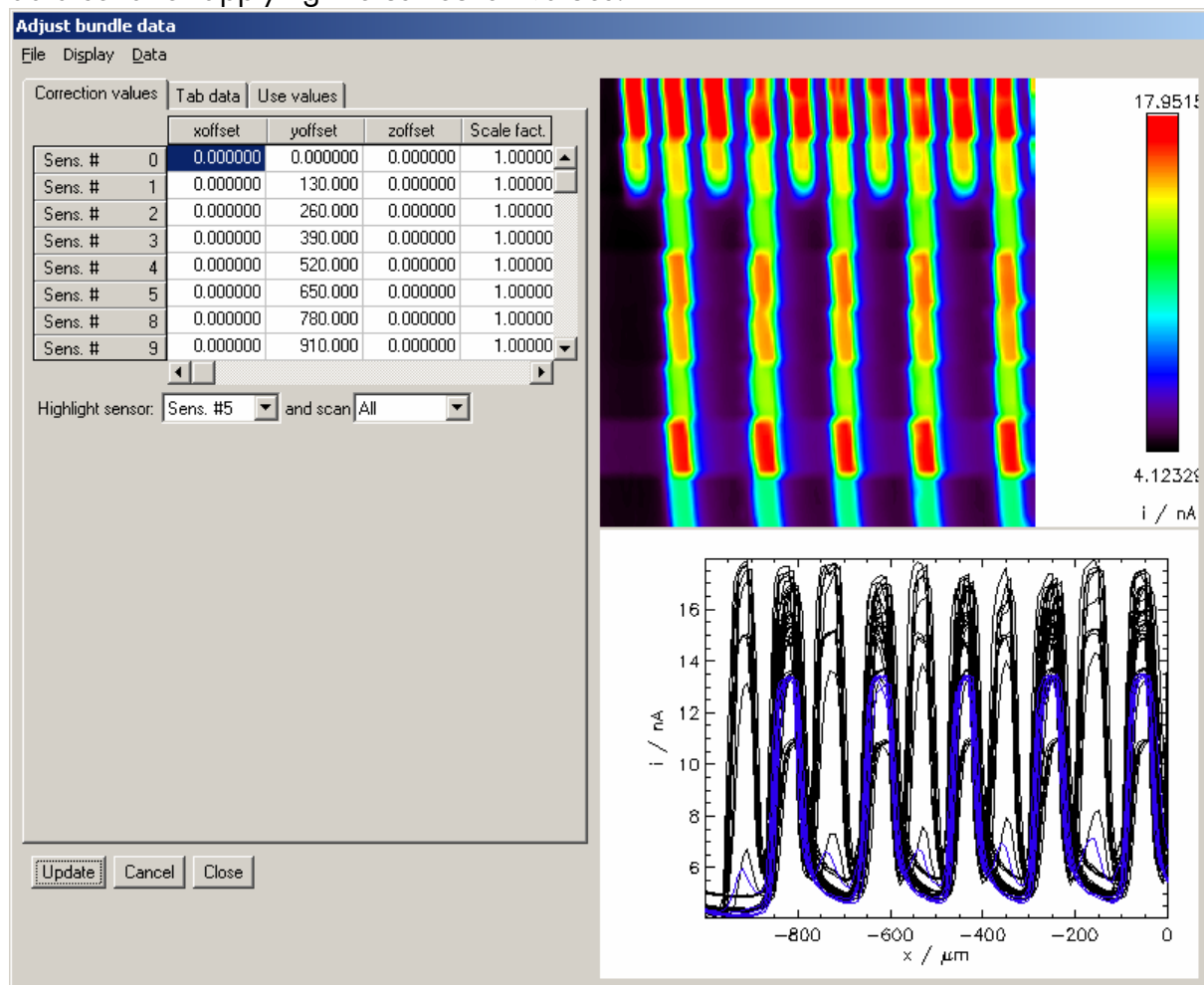

Fig. 96: Window for adjusting bundle data.

The tab *Use values* also allows using extrapolation for making an image by checking "Extrapolate to rectangle". The extrapolation is connected with a particular way of interpolating data from the neighbouring points. The effect becomes visible if different *xoffsets* for the sensors are entered. If extrapolation is not used, the edges of the image looks rugged because each sensor covers a different range of x coordinates in one scan. Extrapolation estimates the values from the neighbouring ones. This gives excellent results if there is not too much slope towards the edge of the image. However, situations can occur in which there is a slope and then the extrapolated points tends to be the largest/smallest of the image. Then extrapolation must be switched off. The situation can also occur if a certain region was imaged two times.

This means that the last scan of one sensor scanned the same area as the first scan of the next sensor. In this case, very high slopes may occur within an image because different values are measured at (almost) identical horizontal coordinates and the slope approaches infinity. Then the computed images usually contain a few very large and very small data and all the rest looks flat because the color scale is spoiled by the very large and very small values. Also in this situation extrapolation should be switched off.

If the box "Extrapolate to rectangle" is checked, the interpolation is made by IDL's routine using Akima's quintic polynomials from "A Method of Bivariate Interpolation and Smooth Surface Fitting for Irregularly Distributed Data Points" in *ACM Transactions on Mathematical Software*, 4, 148-159. If the extrapolation is not checked, linear interpolation will be used.

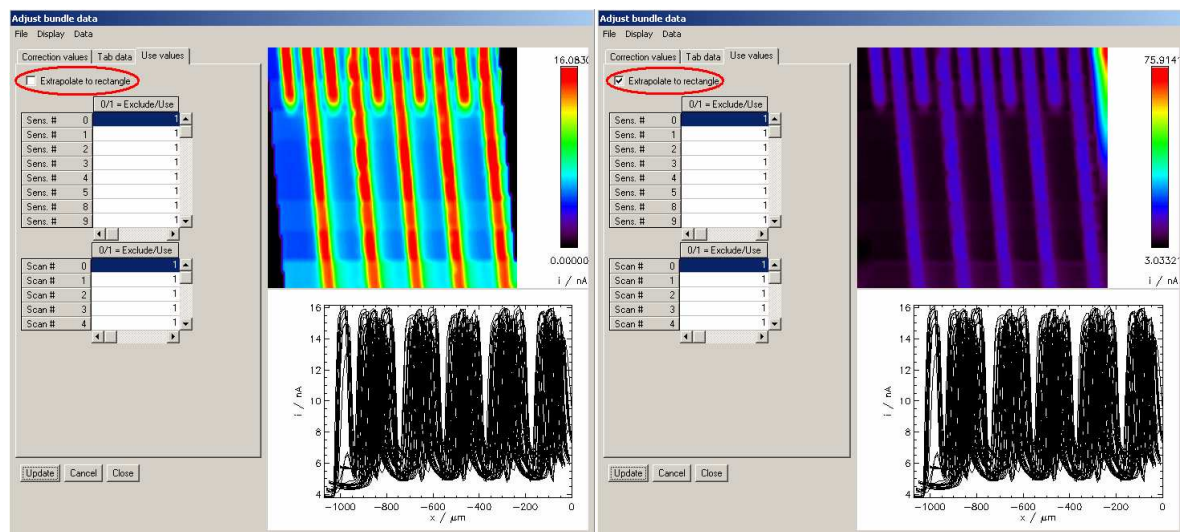

Fig. 97: *xoffsets*; without (left) and with (right) Extrapolation.

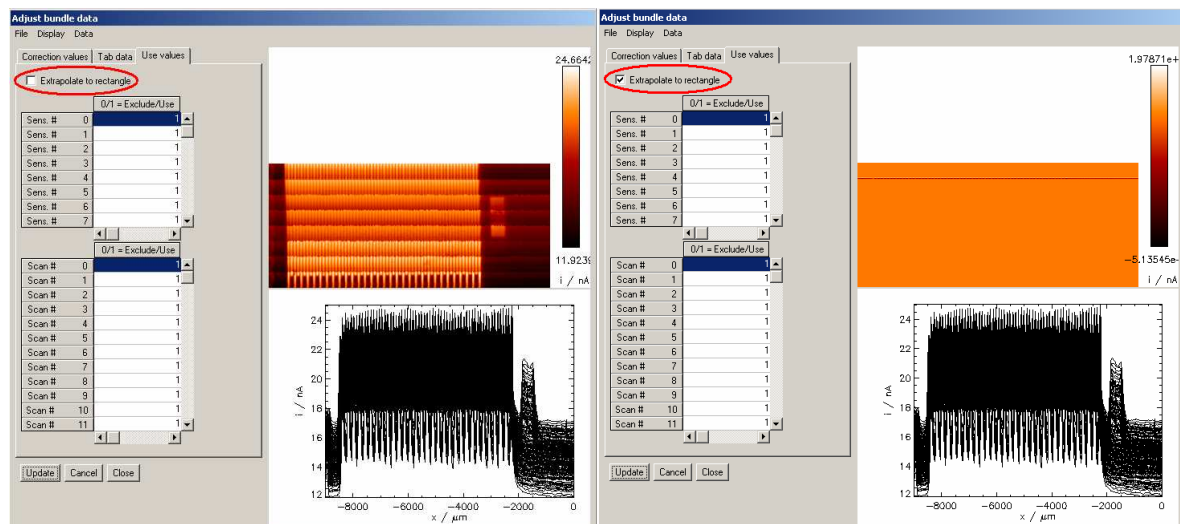

Fig. 98: Double scanned areas; without (left) and with (right) Extrapolation.

<Cancel> closes the window without transferring any changes to the original data set.  
 <Close> transfers the edited data to the data handling routines.

It is recommended to use *Adjust bundle data* first, and then perform further fine tuning of the image (subsets, rotations etc.)

### 3.7.8 Edit data

With this options individual values can be edited in a manner known from spreadsheets (spikes in 2D data sets). For a (x,y,z) data set, a table of all z values in matrix format will appear. For a 2D data set only a column or row of the dependent values (y) will appear.

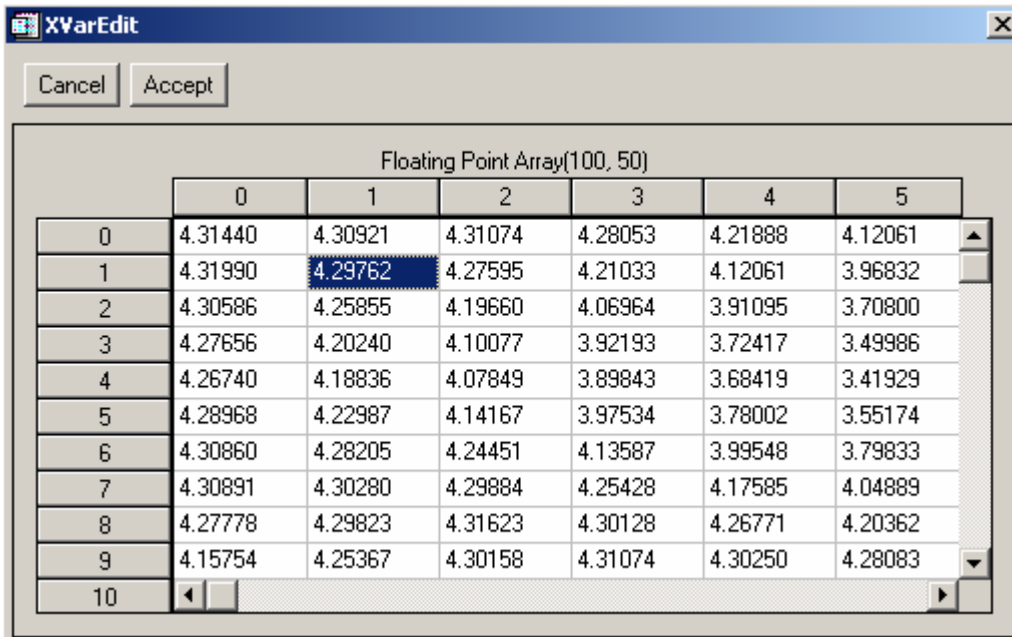

Fig. 99: Unchanged data sets.

In order to change a value, click on the cell and press **<Enter>**. The value becomes editable. After changing the value, press again **<Enter>**.

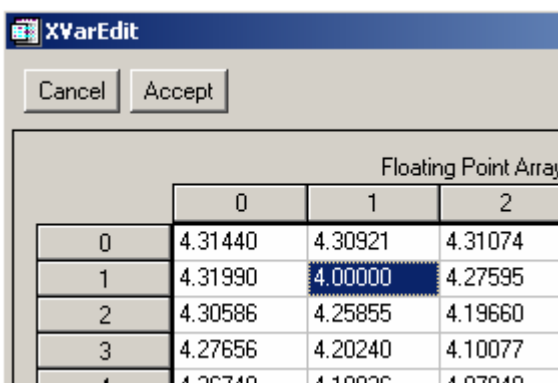

Fig. 100: After editing.

After pressing **<Accept>**, a window appears showing the input data and the result after editing individual values. You may change the plot type under Plot/.. (Fig. 86, right).

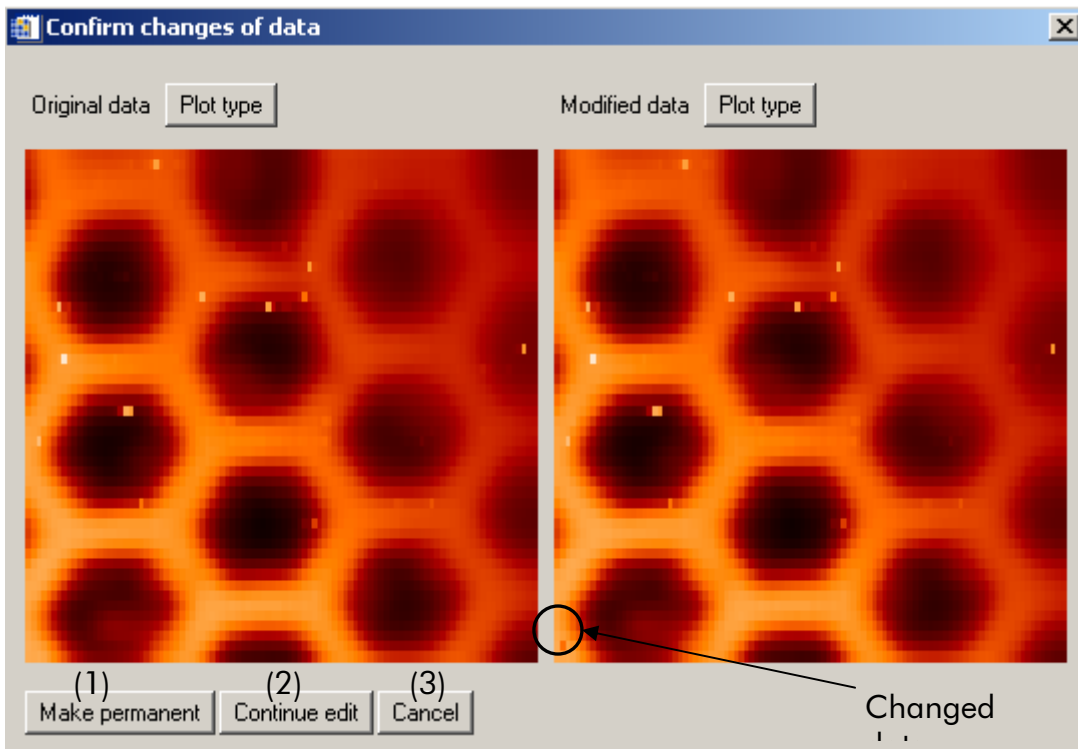

Fig. 101: Changed data in comparison with the unchanged version.

Three options are available now:

You get the last chance to cancel your changes (3).

You can make your changes permanent (1).

You can return to the table for editing (2).

## 3.8 Analysis

### 3.8.1 Profile

This option gives you the chance to analyze a profile along a freely defined line. In Fig. 102 the window is shown in which you can select the line for the profile. **NEW:** Place the cross-hair on the begin of the line. Click and hold the left mouse button. Move to the end of the line and release the mouse button. The profile is presented below the plot. Inputs for the printer/graphic format number and the thickness of the profile line in the upper plot are included, too. Results may be exported as table or graphs with options under *File/...* The menu options are analogous to the File menu options in *Single Plot*.

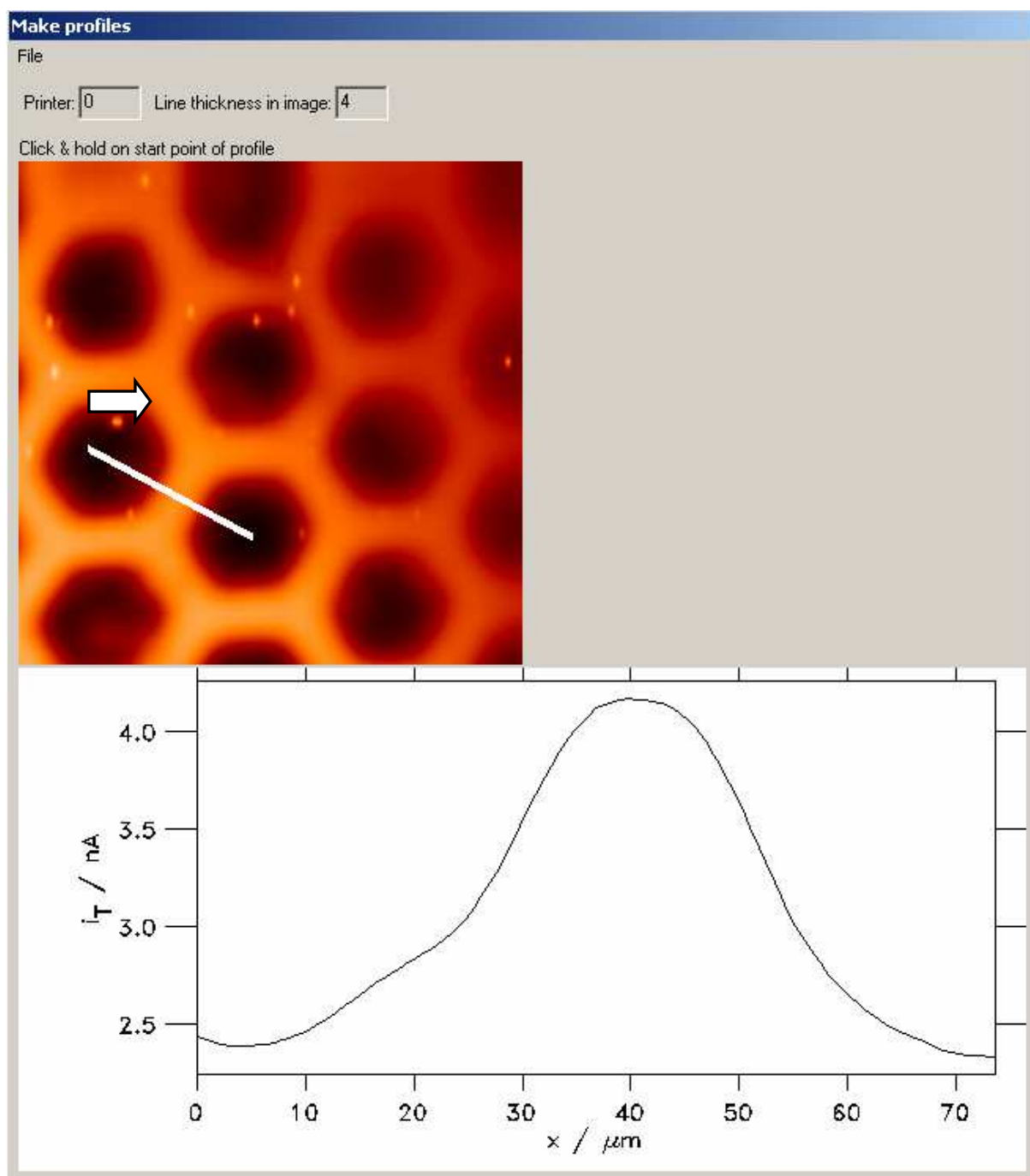

Fig. 102: Profile along the white line in the upper image.

### 3.8.2 Evaluate spot array

This tool facilitates the evaluation of spot arrays in combinatorial approaches. The description below is made with the file 16\_04\_27\_141515.img from the folder \COMBINAT\_CHEM of the demo data sets. A citable reference for the routines together with more explanation and examples can be found in:

D. Kimmich, D. H. Taffa, C. Dosche, M. Wark, G. Wittstock; Combinatorial screening of photoanode materials - uniform platform for compositional arrays and macroscopic electrodes. *Electrochim Acta* 2018, 259, 204-212.

The image is made of an array of spots. Each spot may have a different composition. The local signal is considered proportional to the activity of the material of the spot. The aim is to calculate the intensity for each spot and to produce a hit list. The program can deal with mis-alignment of the material array and the scanning direction of the readout-procedure and offers several routines for the calculation of intensity.

The routine does not work if between loading and processing Arithmetic transformation were applied to  $x$ ,  $y$  or intensity data.

An rectangular layout of the array is assumed.

It is further assumed that the data set from the readout procedure contains much more image points than there are materials spots in the library. In the example, there are  $120 \times 120$  data points for a material library with  $21 \times 19$  materials. While the program can handle mis-alignment (as in the example data set), it is recommended to avoid this. Further it is recommended to have the same grid spacing in horizontal and vertical direction. If this is not provided by the measurement, you can force it with *Data/Resize array*.

The general procedure is the following steps:

- 1) Loading data (Attention this may take a while as such images tend to be large!!)
- 2) Give the main features of the array (corner points, dimensions, radii of spot and background to be applied of each spot
- 3) Create and initialize a data set with material properties
- 4) Refine coordinates of spots center
- 5) Recalculate the spot radii
- 6) Refine the association of individual image point to spot, or to local background for each of the spots
- 7) Calculate the intensity and produce a hit list
- 8) Work with the hit list.

#### Step 1 and 2: Property of the material library

After loading the image from MIRA main menu, call *Evaluate spot* array from the button **Analysis**.

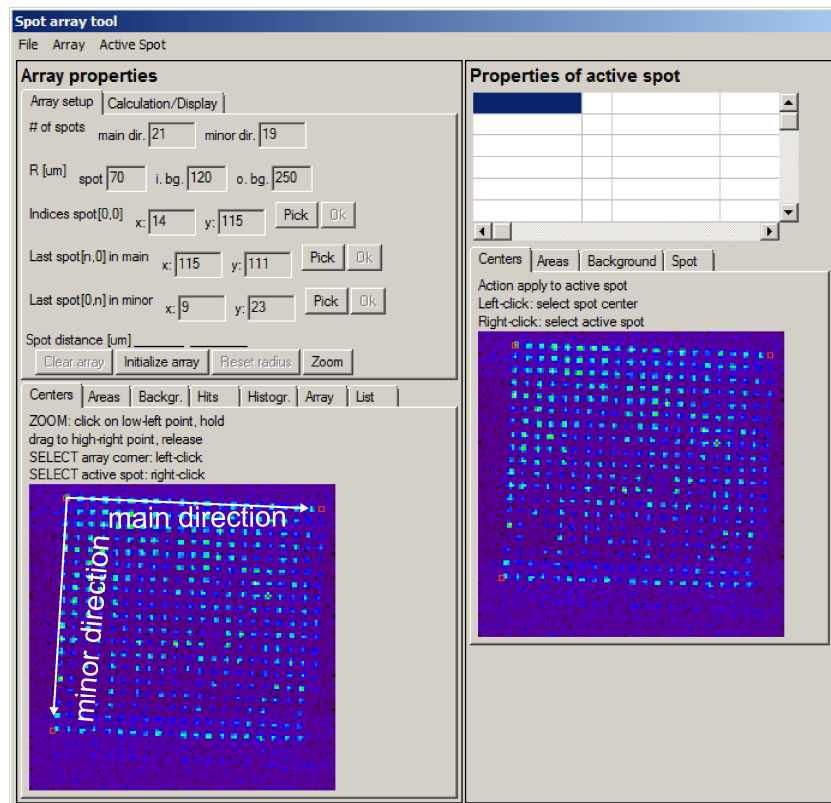

Fig. 103: Setting properties of the material library.

Enter the properties of the material library as shown in Fig. 103. One of the directions is called main direction, the other dimension is called minor direction. The assignment determines how MIRA assigns spot numbers to each material spot. Typically the composition is incremented along the main direction ([A]/% 1, 2, 3, ...). Larger steps are made in minor direction (e.g. first row 0-9 % A, second row 10 to 19 % A and so forth). However, this is not a requirement for MIRA. The user must keep the correlation between the composition of a particular spot and its position within the array. It is advised to apply markers in the library that allow easy relocation and help in detecting transformation (rotation, mirroring) during measurement and data treatment.

There are three radii required (Fig. 104). **All radii must be given in the length unit of the x and y axes. Please note that the unit of the x and y axes may be changed during loading the data set.** X and y axes must have the same unit. All data points of the image that have a distance smaller than the radius  $r_1$  from the center of the spot are considered to be part of the spot. Their intensity is used for the calculation of the spot signal.

All data points whose distance from the spot center is larger than  $r_2$  and smaller than  $r_3$  from the local background for background correction of each spot. Data points that have a distance larger than  $r_3$  (belong to the next spot) or larger than  $r_1$  and smaller than  $r_2$  (transition zone between spot and background) are not considered for intensity calculation. The decision is made based on the distance to the spot center.

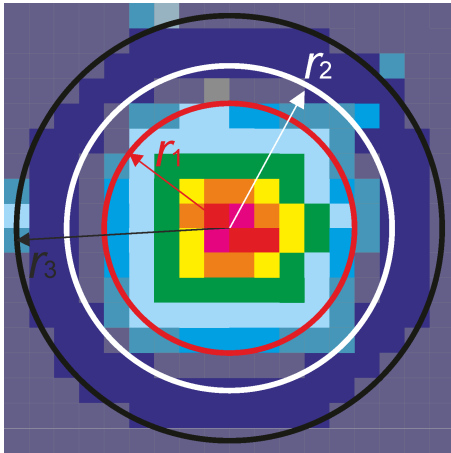

Fig. 104: Definition of the radii that determine if an image point is considered to be part of a particular spot or parts of his background or ignored for the calculation of the intensity of that spot.

In order to select the corner points, click on **<Pick>**, select with the mouse the point in the image and confirm. In case it becomes difficult to see the image points properly, use **<Zoom>**. The left-click on lower left corner, hold and release above upper right corner of the section you want to see. The area appears in the right image. The spot can be selected by left-click in the left or right image. If you need to correct the position just click again on another point. The selection will change. After that confirm the position of the particular point by selecting **<Ok>** next to the **<Pick>** button selected.

### Step 3: Create and initialize a data set with material properties

After selecting the basis material properties, the data set is initialized by clicking on **<Initialize array>**. That means, fields are created to hold data for each material spot to be determined in later calculation

To undo the initialisation (e.g. if the array dimensions were entered incorrectly) use the **<Clear array>** button and re-enter the data required in step 2. All previous calculation will be lost.

### Step 4: Refining e coordinates of spots center

The refinement is often necessary if the printing and subsequent processing caused small deviations from the perfect array layout.

First zoom into the interesting region. Click on **<Zoom>**. (If it is not available click on **<Pick>** and **<Ok>** buttons for one of the corner spot selection.)

In the overview select the active spot with a right-click (i.e. the spot for which corrections are made). The active spot is marked by a white rectangle, the other spots are marked by a black rectangles in the original and zoom image. The current data of the active spot are shown in the table on the top of the right column in Fig. 105. In the zoom image correct the spot center with a left click. The active spot may also be selected in the zoom with a right-click. After the entire array has been checked by sequentially loading section of the array in the zoom window, all spot centers are corrected. At this point the initial assignment of image pixels that are considered as spot or as local background has not been changed.



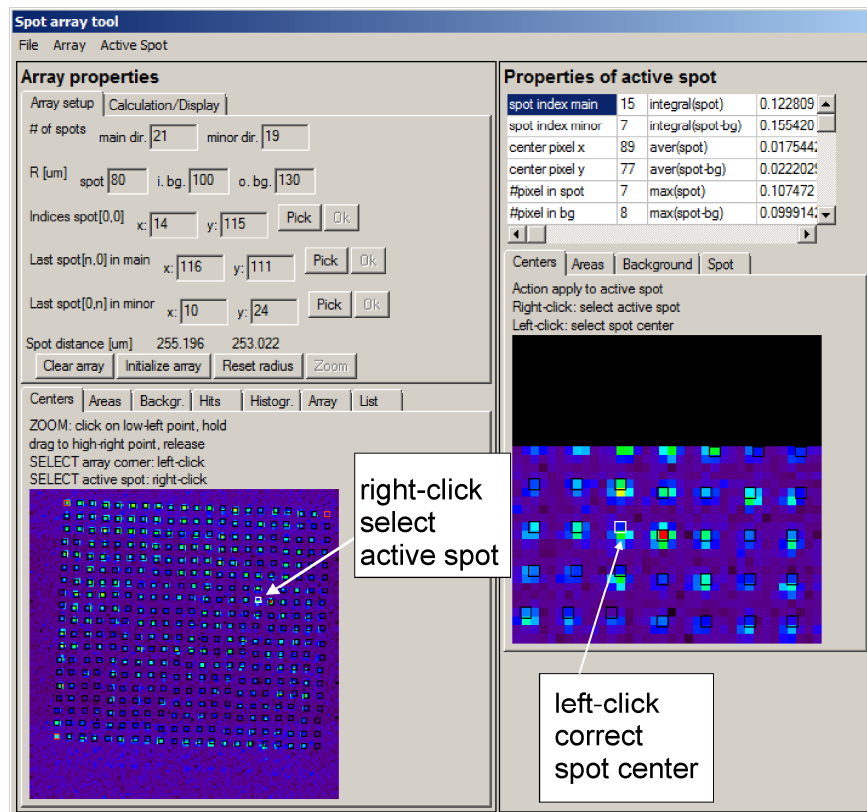

Fig. 105: Tool for refining the spot center. On the left half select the active spot, in the zoom image correct the spot center.

### Step 5: Recalculate the spot radii

After correcting the spot centers, the initial assignment of pixel to the spots of the local background must be changed. This can also be used to refine the values of  $r_1$ ,  $r_2$ , and  $r_3$  according to the layout of the array. In the model data set a suitable values could be  $80 \mu\text{m}$ ,  $100 \mu\text{m}$  and  $130$  or  $140 \mu\text{m}$ . After entering corrected values for the radii press **<Reset radius>** in the upper part of the left side of the tool in Fig. 105. This can also be used to recalculate the pixels for the spot and the local background even if no radius had been changed. The operation can be repeated until a reasonable representation has been achieved for pixels belonging to the background and the spot itself. most spots. This may not be possible for all spots with one radius setting. Therefore, this assignment can be refined in Step 6.

### Step 6: Refine the association of individual image point to spot, or to local background for each of the spots

The tabs *Area* and *Background* for the original image and the zoom can be used to check if the assignment is reasonable. If the radius must be changed for all spots, repeat step 5.

In many cases the radii will be appropriate for most spots but not for all. In those cases switch to tab *Centers* on the left side, select the active spot and correct individual assignments in the zoom window. Right click on the pixel unselects it for the background or area, left click selects the point.

**Note:** One particular pixel may be part of the background for two spots. However, it does not make sense if one pixel is part of the spot and at the same time part of any background or of another spot.

**Note:** all individual assignments are lost after using **<Reset radius>** or **<Initialize array>**.

The quality of the assignment for each spot can be checked in the tab *Spot* on the right side (Fig. 106). It shows the pixels forming the spot in red and the pixels forming the background in black. The calculated background is also shown in blue.

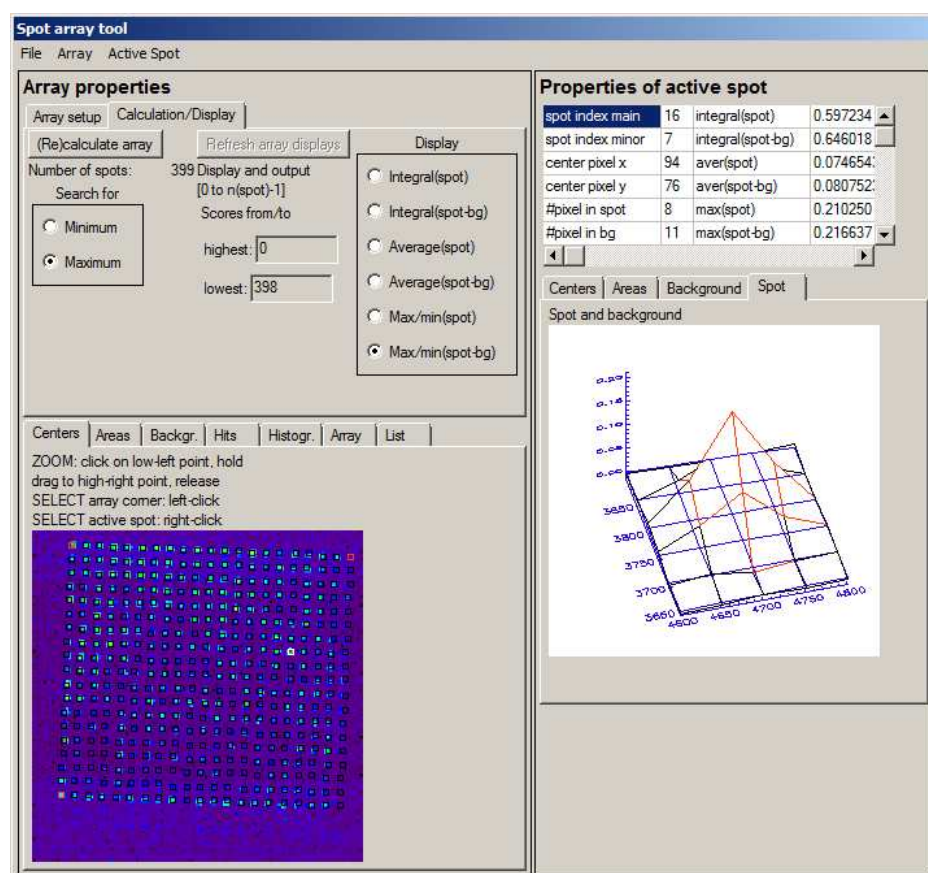

Fig. 106: Display of the active spot. Pixels that for the spot are in red, the calculated background is shown as blue grid.

### Step 7: Calculate the intensity and produce a hit list

After each point (or at least each relevant point of the array are set-up properly) switch to the tab *Calculation/Display* on the top-left of the Spot tool (Fig. 106). Select if a minimum signal (largest reduction current) or a maximum signal (largest oxidation current) indicates an active spot. After that use **<Recalculate array>**. For each spot the signal is calculated according the six options given by the radio button on the right.

**Note:** Depending on the computer resources and the size of the array, this step may take a while.

After completion the button **<Refresh array display>** becomes available.

### Step 8: Working with the hit list

Once all intensities have been calculated, one can work with the hit lists, mostly saving and displaying the results in various ways.

The results may be saved by *File/Save current status* to MIRA's own binary data format. Those data may be loaded later by *File/Load data and status, overwrites current status*.

For loading binary data, you must first open the Spot tool with any other image, e.g. one example from the demo data sets. It is not required to have an actual material library to be loaded first.

**Note:** MIRA's internal data format is intended for fast storing and retrieving data for example during an interruption of work. It is not intended for long-term archiving. Its

own format may change from version to version without notice. It is also not backward compatible!!

For long term storage the hit list may be saved as ASCII file containing the sorted intensities according to one of the algorithms for intensity calculation.

The storage of a spot list prints the results in the order of the spots in the array independently on their particular performance. This file may be used to combine data from different evaluation methods of the spot array outside of MIRA.

The results can be visualized in different ways. First select the calculation algorithm in the radio button list in the right part of the tab *Calculation/Display*. The results from this algorithm will be used to generate the displays. You may also restrict the display all spots or only the  $n$  most active spots that are considered to be hits. In the tab *Histogram*, one can see the fraction of spots that is covered by the current restriction (Fig. 107a).

The location of those hits can be seen in the tab *Hits* (Fig. 107b).

The tab *Array* shows the intensities of each spot and produces a new image in which each pixel corresponds to one material spot of the library (Fig. 107c). The origin is in the lower left corner. The main direction goes to the right. Any mis-alignment and all background data are removed.

Note the different orientation between the original image under tab *Center* or in Fig. 107b and the spot array (Fig. 107b).

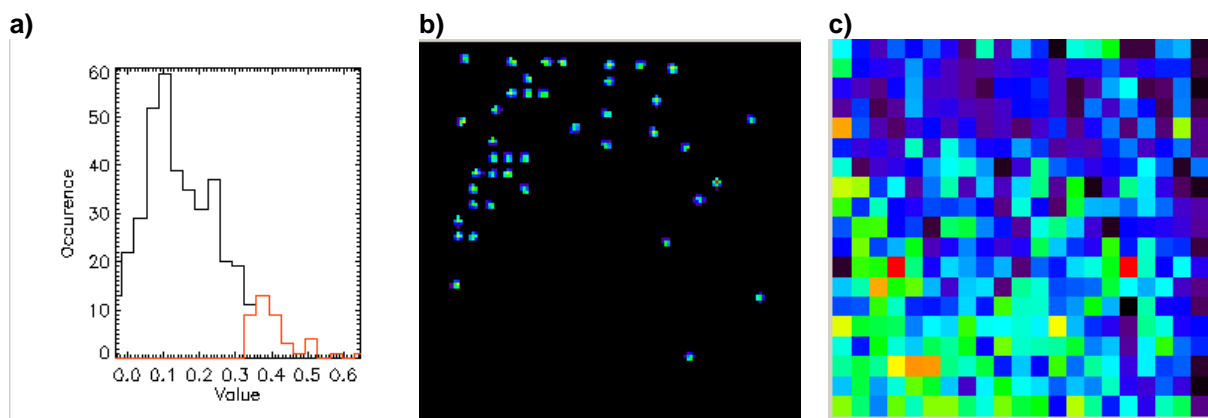

Fig. 107: a) Histogram with selected spots for the hit list in red, b) location of the hits within the spot array, c) the intensities for each spot are used to form a new data array that is shown without background.

### 3.8.3 Histogram

Histograms show the occurrence of values within a given interval. Such plots can be used to optimize color shadings to show the important details. If for instance, a few values are much larger or much smaller than the bulk of the data, it might be worth setting the upper and lower limit of the color scale such that it is spread only about the bulk of data points. Histograms are characterized by a minimum and maximum value considered and the interval (*binsize*) over which the occurrence is counted. The initial settings are min/max of the data set and 2 % of the data interval for *binsize*. They can be changed and new histogram plots are calculated after pressing **<Execute>**. The

result can be exported in all graph formats or as an ASCII data set. The menu functions in the histogram window are equivalent to the ones in *Single Plot*.

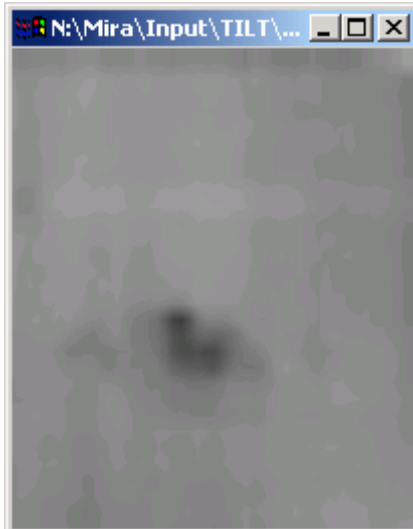

Fig. 108: Example plot.

The histogram of Fig. 108 will look like this:

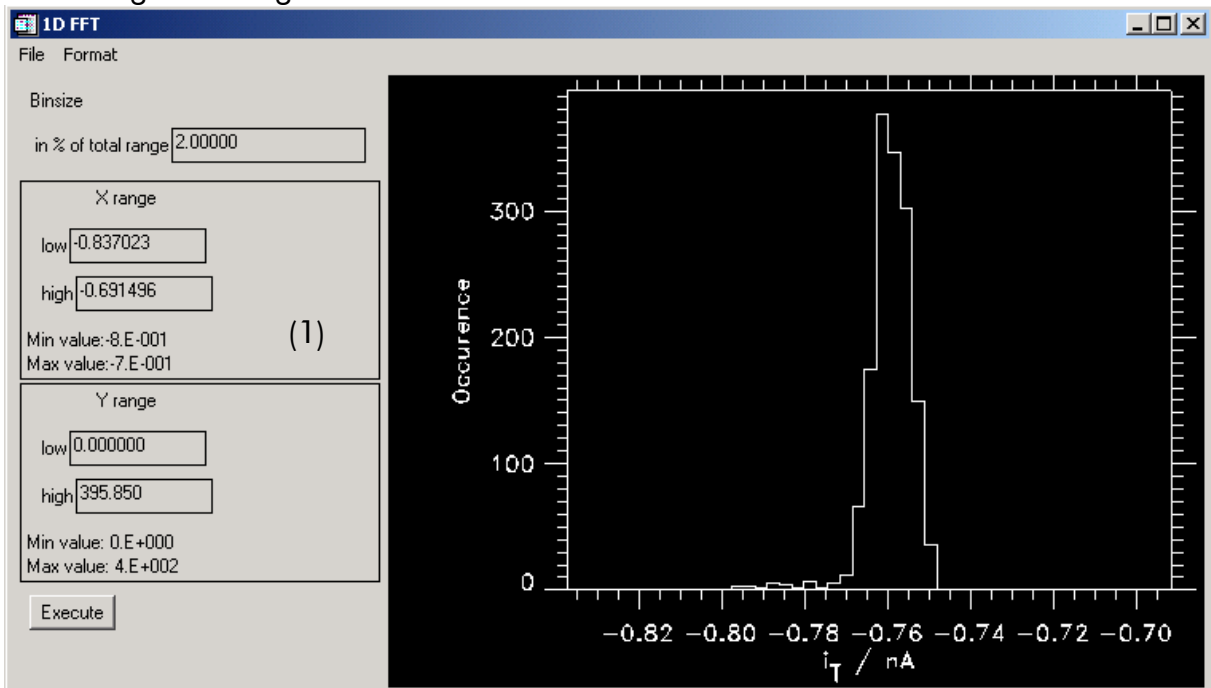

Fig. 109: Histogram Fig. 108.

### 3.8.4 1D FFT (Fast Fourier Transformation)

1D data sets (time series) are using the Fast Fourier transformation. You may have to change min/max of the plot to see the results in an optimized way.

### 3.8.5 Optimize AD Filter

This is a special function helping in optimize custom made instruments using Analog-Digital (AD) Converters. Often certain frequencies show up in the recorded signals (line frequency). Because of analogue-digital-commutations interferences get inducted to the plot. Using simple, but specifically optimized digital filters can eliminate these

discrete frequencies almost totally. In our laboratory we accumulate and average the AD values with the maximum frequency of the AD card over one period (1/50 s, 1/60 s in the USA). The average value contains as many points on the negative half cycle of the noise component as on the positive half cycle. Both contributions are canceled, if the accumulation time is exactly the period (or multiple) of the line frequency. The maximum AD conversion rate given in the product description is only realized approximately. Therefore it turned out to be important to optimize this number for each system. This functions helps to do it. It loads a time series recorded with the maximum AD conversion frequency and searches for the size of the best box-car filter.

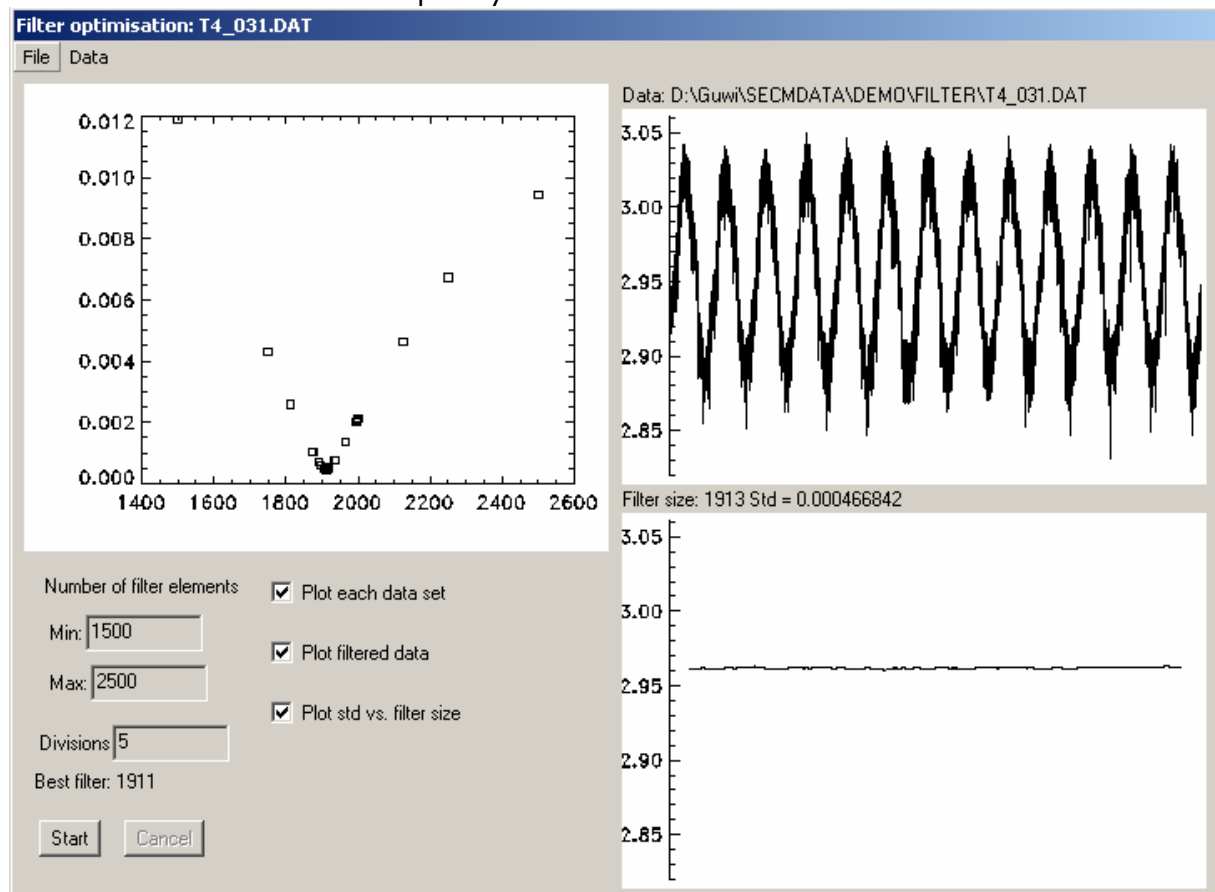

Fig. 110: Window for optimizing AD filters.

Select *Min/Max* and press <**Start**>. *Min/Max* should be selected such that the theoretical best count number ( $n = k * (1/\text{line frequency}) * \text{frequency of AD card}$ ) is in the middle of the interval. The settings in Fig. 110 are appropriate for a line frequency of 50 Hz and AD card of 100 kHz and  $k=1$ . The check marks on the right control the graphic output during operation. Unchecking these options accelerates the processing. This can be significant when treating many data sets. This procedure can also be performed with several time series in order to get a statistically sounder analysis. In order to do so, load several data sets into *Multiplot* (see description on *File Open* or *Batch Processor* in the *Multiplot* chapter of this manual). Display the first AD time series in one of the graph windows in *Multiplot*. Start the *Optimize AD Filter* from the *Multiplot* window. Now all loaded AD time series are analyzed one after the others and the optimized filters are given (Fig. 111). For larger data sets the processing may take several minutes. The plots during processing (if checked) are the same as in Fig. 110. They are updated as the processing proceeds from filter size to filter size and from data set to data set. The final output contains a histogram of the best filter size (top left), the best filter for the

data sets in sequence of the file list in *Multiplot* (top right) and the standard deviation of the filtered data after application of the best filter for each data set (bottom right).

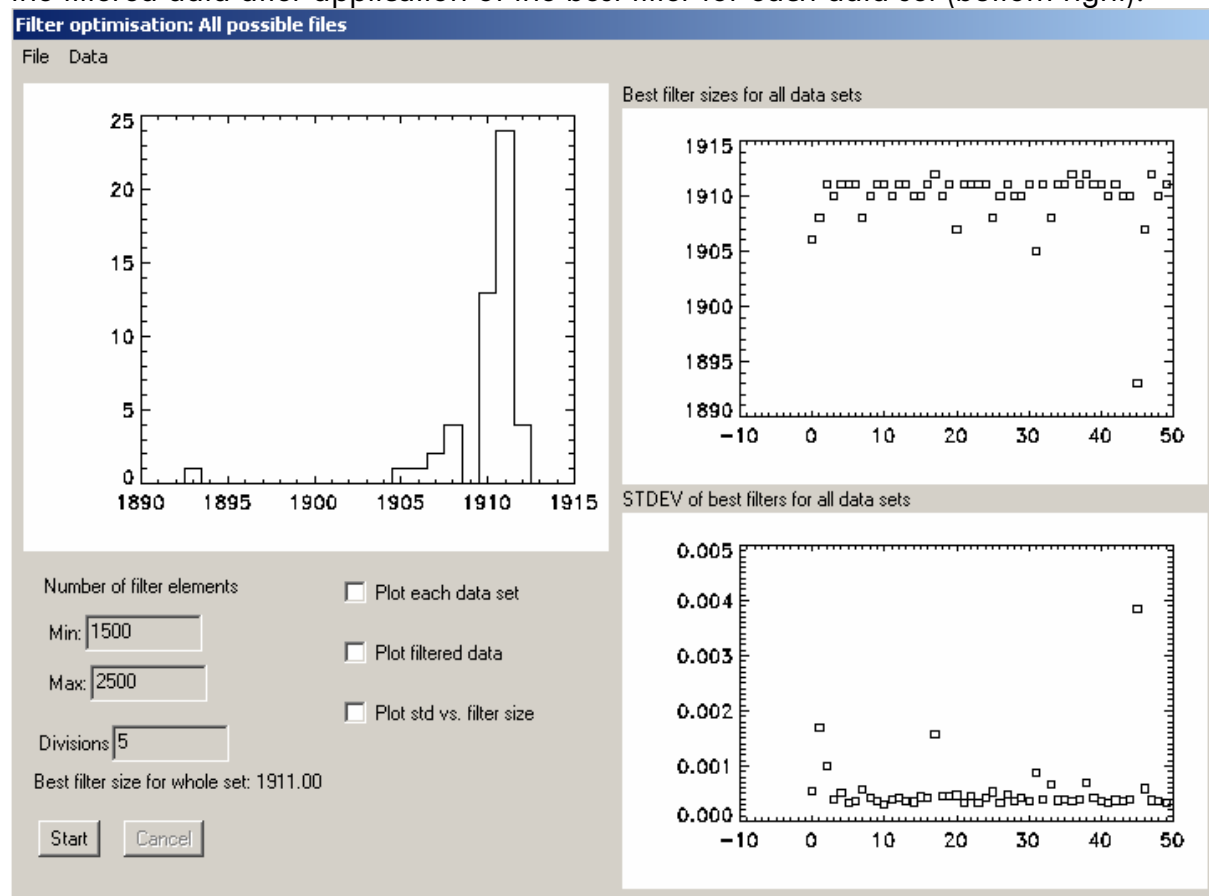

Fig. 111: Output for processing 50 time series in *Optimize AD filter*.

### 3.8.6 Curve fit

Curve fit is a module that fits SECM approach curves to the theory for infinite fast electron transfer at the sample and for very slow electron transfer at the sample. Further models that might be of interest are included: generation collection (GC) horizontal line scan across the center of a pore from which particles are diffusing into the SECM cell, GC approach curve above a pore center, Michaelis-Menten kinetics. All models are fitted by non-linear least-square fitting.

Theoretical models from the following papers are included.

Amphlett, Denuault; *J. Phys. Chem.* **1998**, *102*, 9946.

Shao, Mirkin; *J. Phys. Chem.* **1998**, *102*, 9915

Mirkin, Fan, Bard; *J. Electroanal. Chem.* **1992**, *328*, 47

Scott, Bath, Lee, White, Scott; *Anal. Chem.* **1998**, *70*, 1047.

Lefrou, *J. Electroanal. Chem.* **2006**, *592*, 103.

Cornut, Lefrou, *J. Electroanal. Chem.* **2007**, *608*, 59.

Cornut, Lefrou, *J. Electroanal. Chem.* **2008**, *621*, 178.

Scott, Bath, Lee, Whize; *Anal. Chem.* **1998**, *70*, 1047.

The general aim of the curve fitting consists in extracting physico-chemical constants from the measured curve. The theoretical response is available as an analytical function. The analytical functions results either from a mathematical treatment of the problem or from an interpolation of digital simulations for discrete points.

**WARNING:** The proper use of fitting programs requires a detailed understanding of the underlying theory. Neither the program nor this manual can replace a thorough study of the original papers. Users must be aware of the limitations of each model and their experiments. This manual does not attempt to give a complete overview on the curve fitting. It intends only to explain the proper use of the program. If questions remain open, please contact Gunther Wittstock.

As an example, we consider the approach curve of a UME to a gold surface. Load the curve into *Single Plot*. If loaded into *Multiplot*, display it into one of the graphs to make it the present data set. Select the color table 39 (Rainbow + White) in order to get the same colors as used here. Start *Analyse/Curve Fit*. The following window appears.

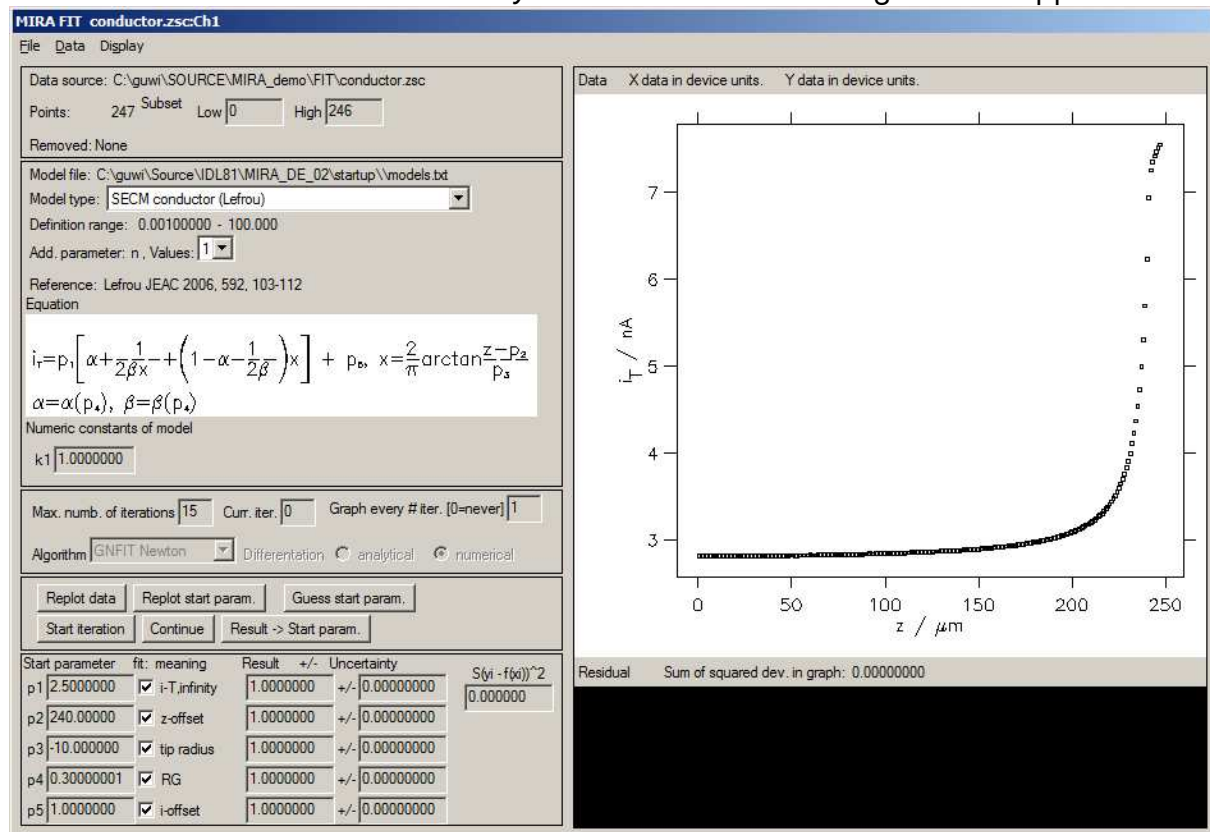

Fig. 112: Startup-screen for *Curve Fit*. Data set is a SECM approach curve to gold.

In order to prepare the processing proceed from top to down and left to right of the different controls.

The last 6 points of the data set at the right side of the display clearly do not follow the theory probably because the glass sheaths of the electrode touched the sample. Such data points should be excluded from the fitting procedure. To do so set the field High: on  $246 - 6 = 240$ . You can press <Replot data> (left bottom) to see the new selection. Individual data points (spikes etc.) can be excluded by a spreadsheet. This is accessible via the menu *Data/Spreadsheet*. The last column initially contains 1. By setting this value to zero, the data point will be excluded from fitting.

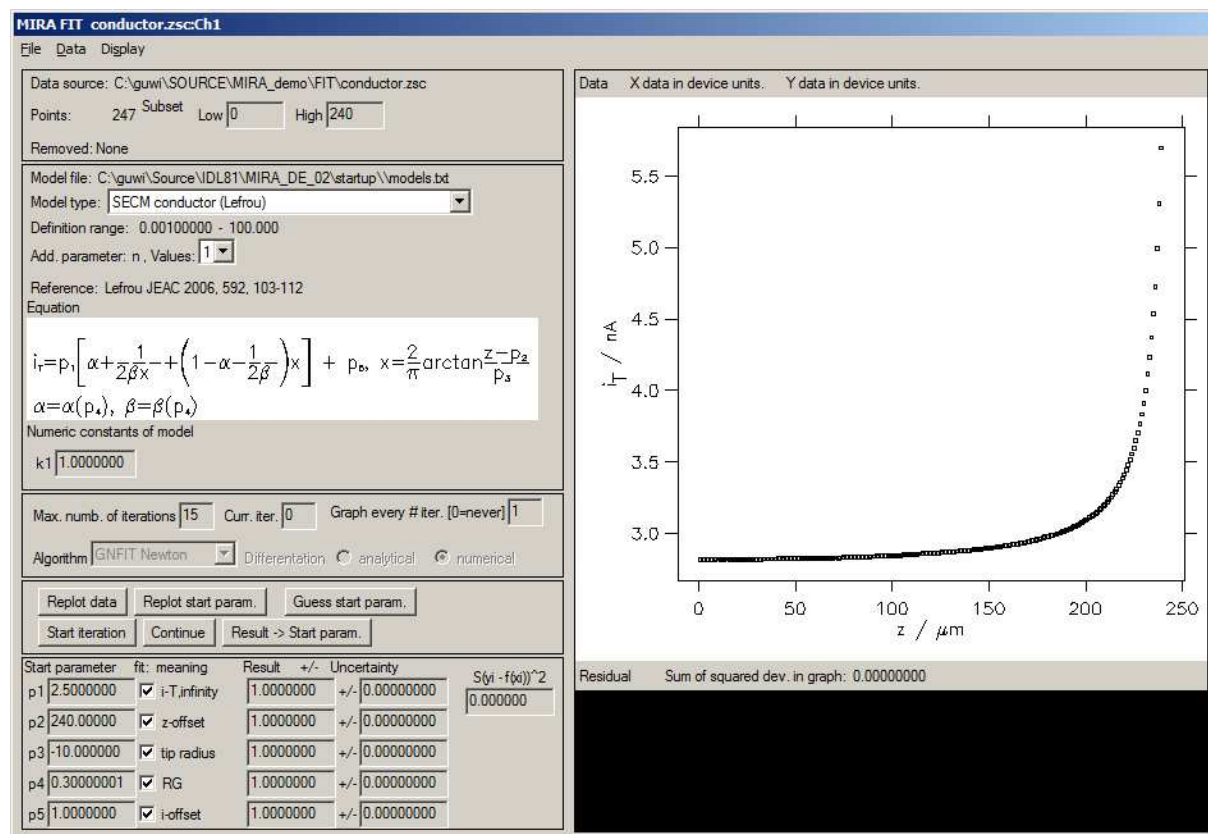

Fig. 113: Curve fit window after excluding the last six data points from fitting and pressing <Replot data>.

Now the appropriate model can be selected. For this data set we know that the experimental current offset of the potentiostat is zero. We can, therefore, select the model in the second frame on the left side with *SECM conductor without i\_offset*. The window is rebuilt and has now only three adjustable parameters on the bottom right. The RG value of this electrode was 16.5. In order to fit the data, we can either use the closest value give in the filed *Add. parameter, RG, Values = 10.2* or select a freely selected RG value (= ?). The freely selected RG value is interpolated from the neighbouring RG values, for which constants are known. Since the RG affects approach curves to a conductor only little, we want to stay with the predefined value  $RG = 10.2$  from the paper of Amphlett and Denuault. (For fits with insulators model, more RG values are available since the curves are much more sensitive to this parameter.) The program will update the equation and the numerical constants as well as the literature reference from which the data are taken. (For some situations, more than one numerical solution is available as a model). The resulting appearance of the window is shown in Fig. 114.

Now details for the numerical fitting routine can be selected. For the SECM models the program usually converges after 7-8 iterations. The settings of *Max. number of iterations* should be set higher. Since processing is so fast it does not hurt to set them to 15. The *Curr. numb. of iteration* will display the progress of the program and cannot be edited. *Graph every ## iteration* controls how often the graph window will be updated. Only for older computers (Pentium 1 and lower) it makes sense to have a value other the 1. "1" means that a graph update will be initiated for each iteration cycle. This will usually be so fast, that you cannot see the individual iteration steps clearly.



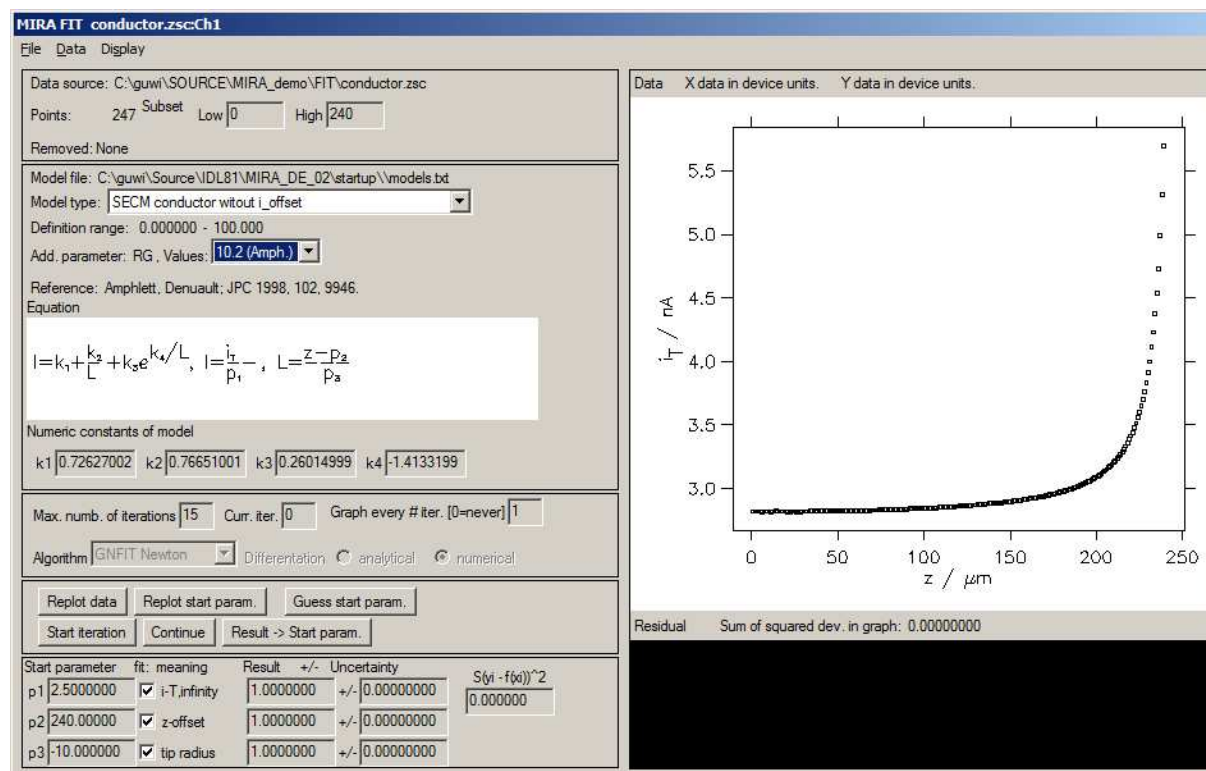

Fig. 114: Screenshot after selecting details of the model.

The field *Algorithm* and *Differentiation* cannot be edited. The program can work with several algorithms for non-linear curve fits and analytical and numerical differentiation. Previous testing showed that the results of the different algorithms are identical. However, the Gauß-Newton fit with numerical differentiation is the easiest to implement and works most reliable, while other algorithms showed problems with some data sets and are more prone to problems. Therefore, the further development of these algorithms is discontinued and will be dropped in the future if experience will not call for the opposite.

The quality of non-linear least square fitting depends on the starting parameters. It is a main advantage and accelerates the data processing enormously that MIRA can provide a good set of starting parameters for most models. For those models that do not have the *<Guess start param.>* function implemented, nothing will happen. After pressing *<Guess start param.>* the window will show the data points and the theoretical function with the start parameters. The experimental points which are within the definition range of the function are displayed in Blue (all for the example). The function with the start parameters is given in Red (Fig. 115).

On the bottom right, the fitting parameter are listed in a table. The enumeration p1 ... pn corresponds to the labels p1 .. pn in the formular display on the left side. The window give the start value of the parameter. The values can be edited after clicking on them. The results can be explored by pressing *<Replot start param.>*. A plot similar to Fig. 115 will appear calculated with the new start parameters. Please be aware that for some models the parameters of the numerical model are not an individual physico-chemical parameter but a combination of them (e.g.  $p_1 = k_{cat} * [E_0]$  in a Michalis-Menten curve). Please note the sign for the electrode radius. The sign should be negative if the z-values of the experimental approach curves are counted positive if

the electrode approaches the sample. It should be positive if the z-values increase with increasing distance to the sample.

The check marks after each parameter indicates that this parameter can be varied during the iteration. For some models parameters are known from independent experiments and the curve could be fitted by more than one parameters sets. In order to avoid this situation, parameter known from independent measurements (e.g. electrode radius) can be set constant in the procedure by unchecking the box. Such a parameter will not be varied and now uncertainty is calculated for this parameter. The small graph below the data set shows the deviation between model and experiment for each data point. The field  $S(y_i - f(x_i))^2$  gives the sum of the squared deviations between experimental points and the model.

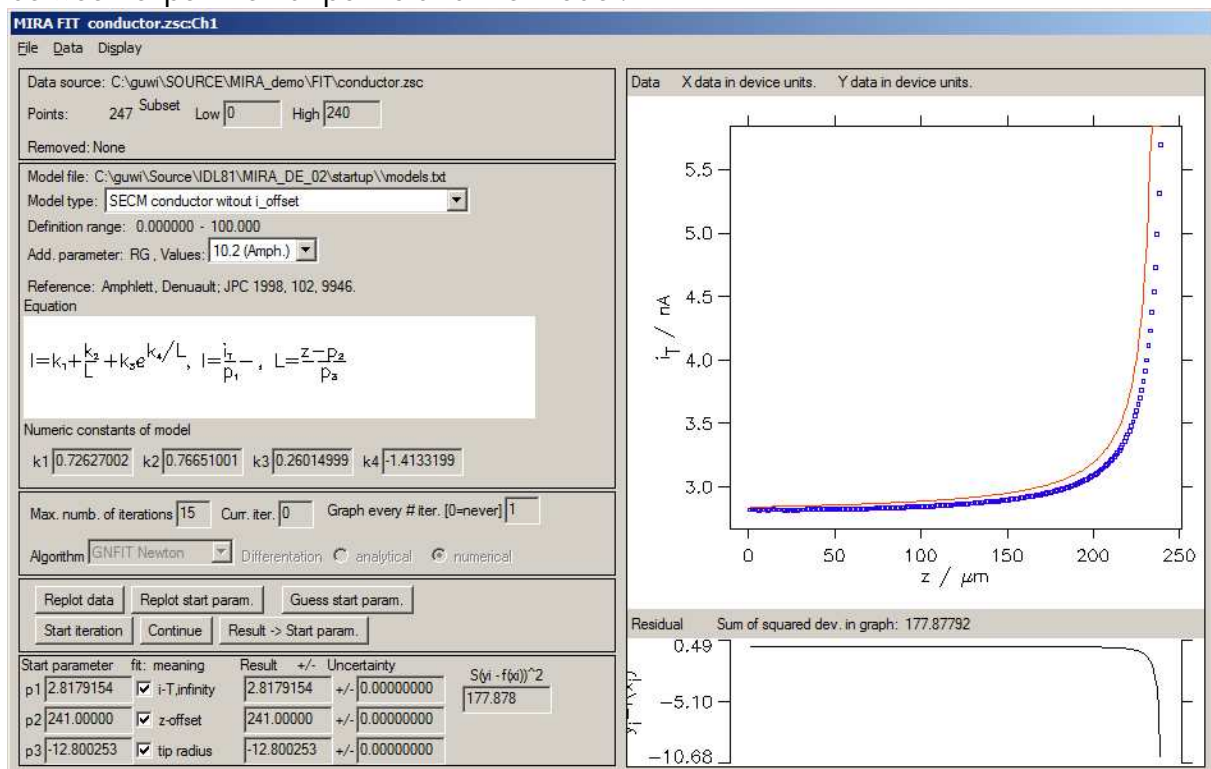

Fig. 115: Screenshot after <Guess start param.>.

If the start parameter are sufficiently close (what is "close" may depend on the model), the fit can be started by <Start iteration>. If the result is not sufficient, iterations can be continued by <Continue>. If the model shall be refined with a different model, or algorithm (currently disabled) the result can be made the new start parameter by <Result->Start param.>. For the example the result of the fitting looks like Fig. 116. The model with the optimized parameters is plotted in Green. The optimised parameters are plotted in the table together with an estimation of the uncertainty of each parameter. The estimates are given as  $\pm$  one standard deviation.

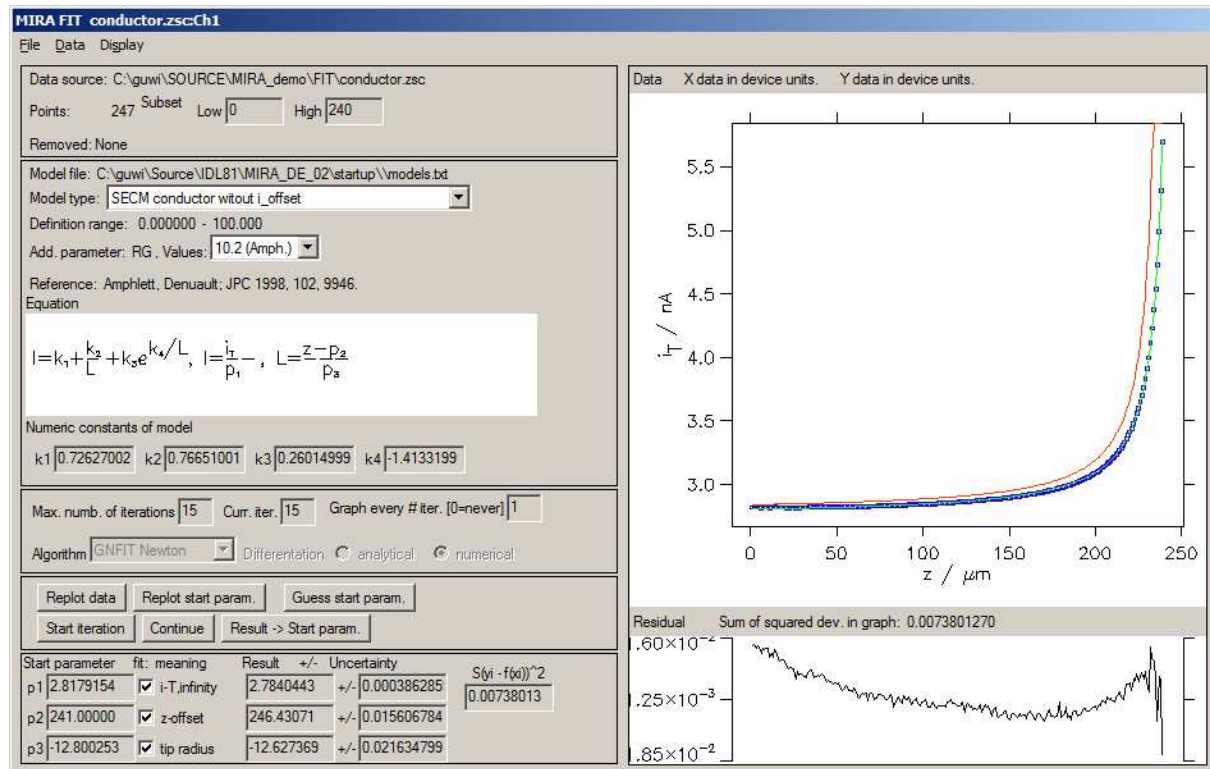

Fig. 116: Screenshot after <Start iteration>.

Working with the result:

Menu File

The menu works mostly like the menu in *Single Plot*. Here is a summary

*Change Default Path*: use it to select the output directory for graphic and text files

*Save/Load IDL binary*: This is for short term storage of fitting (for preparing discussion). It should not be used for long term archiving as each version of MIRA can only work with its own binary files.

*Export fit to ASCII*: Exports data, fitted data and deviations to text file in spreadsheet format

*Export parameter to ASCII*: Exports only the fitted parameter to a file (avoids writing numbers from screen displays).

*Select graphic format*: Selects the output format as in *Single Plot*.

*System printer setup*: Sets up the windows system printer, if you want to direct the output directly to a physical printer.

*Print text results*: Puts the result to graph window.

```

Sun Nov 07 20:07:40 2004
D:\Guw\SECM\DATA\DEMO\FIT\11291531.Zsc, Channel: 1
Number of used data points/data points in set: 241/247
Excluded (0-based index): 241-246

Model: SECM conductor without i_offset

$$i = k_1 + \frac{k_2}{z} + k_3 e^{k_4/z}, \quad i = \frac{i_{\infty}}{p_1}, \quad L = \frac{z - p_2}{p_3}$$

Lit.: Amplett, Denuault; JPC 1998, 102, 9946.
Add. constant: RG = 10.2 (Amph.)
Numeric constants: 0.72627002, 0.76651001, 0.26014999, -1.4133199

Numeric procedure: GNFIT Newton, Computation method for derivatives: numerical
Number of iterations: 15
p1 from 2.8195922 (i-T_infinity), fitted
p2 from 243.00000 (z-offset), fitted
p3 from -11.310088 (tip radius), fitted
    
```

Fig. 117: Graph output from *File/Print text results*.

Print graph:

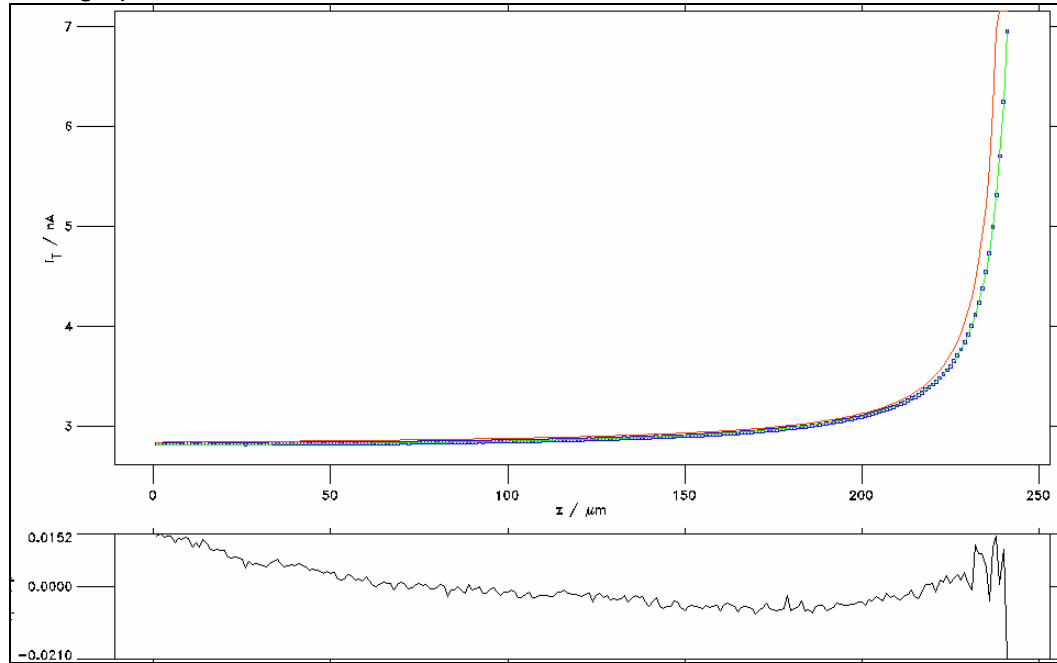

Fig. 118: Graph output from *File/Print graph*.

Print text result and graph:

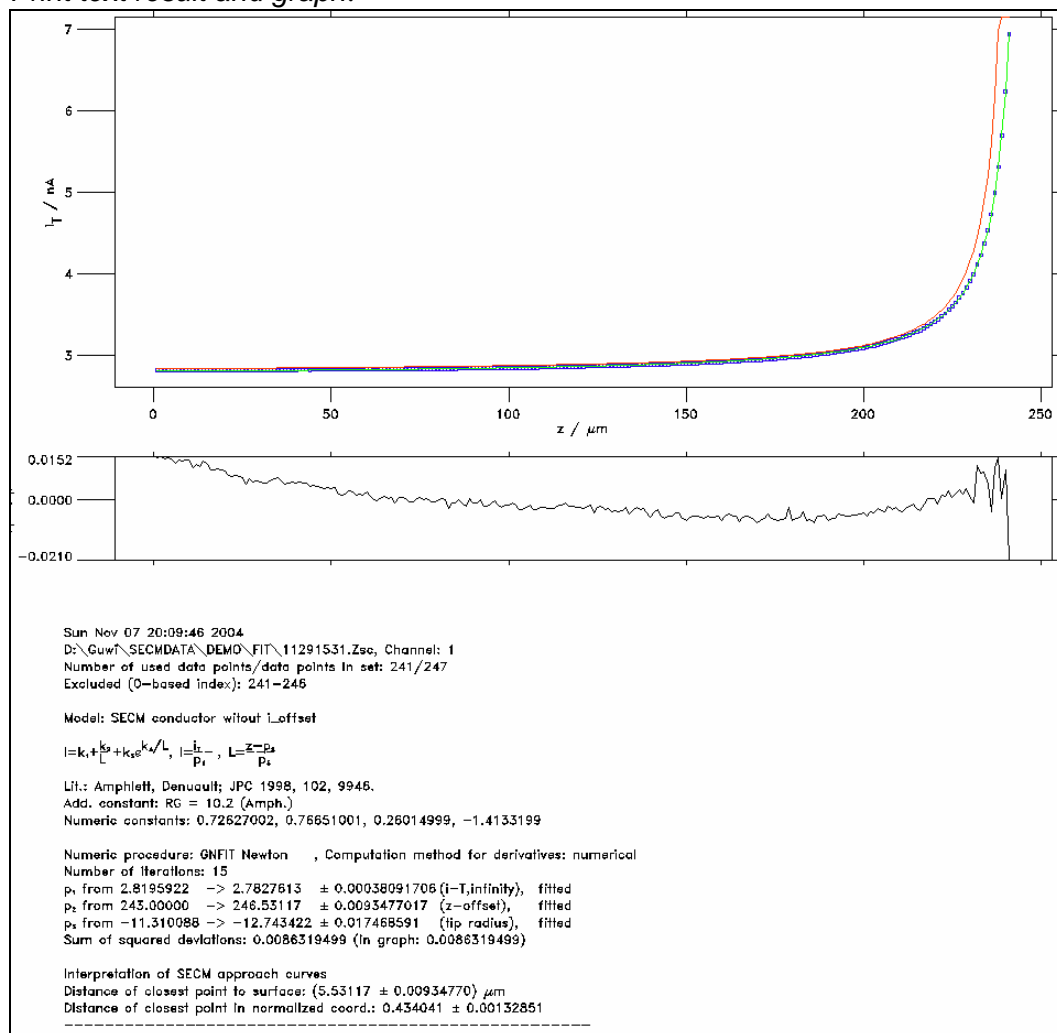

Fig. 119: Graph output from *File/Print text result and graph*.

Print text start and graph:

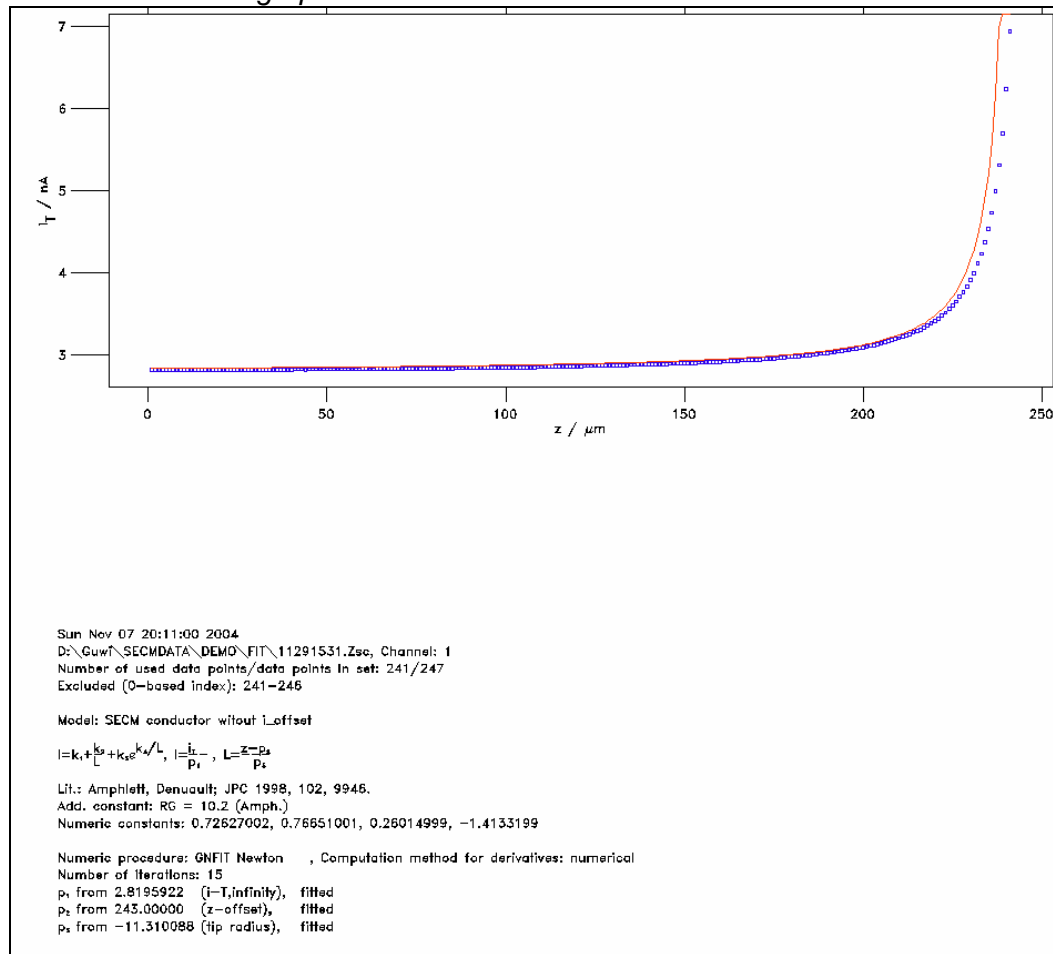

Fig. 120: Graph output from *File/Print text start and graph*.

*Close/open log file:* All operations within *Curvefit* can be recorded in a log file. Here it can be closed and a new one be opened.

*Exit:* Return to *Single Plot* or *Multiplot*

Menu Data

*Spreadsheet:* Individual data points can be edited or excluded from fitting. The settings in the Form Points/Subset overwrite the settings made in the spreadsheet. Use the spreadsheet to exclude outliers in the data set that are not located at the beginning or the end of the dataset.

Menu Display

*Show matrix of 1st part. derivatives:* Shows a vector of the first partial derivatives  $dS/dp_i$  for each parameter.  $S$  is the sum of squared derivatives. This gives an idea on how well determined a parameter is by the current data set.

*Show matrix of the 2n part. derivatives:* Shows a matrix of the second partial derivatives  $d^2S/(dp_i dp_j)$ . This gives indication on how much parameters influence each other.

*SECM data interpretation:* gives the distance of the closest point of the data fitted set to the surface in real and normalized coordinates. In the example the point right at the display in Fig. 116 has a distance of 5.53  $\mu\text{m}$  to the surface.

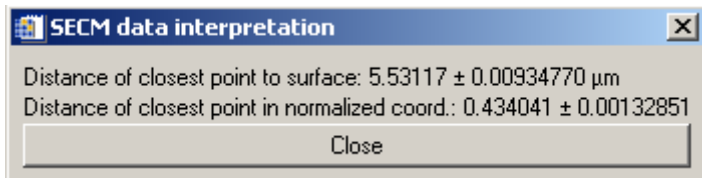

Fig. 121: Output of the menu *Display/ SECM data interpretation*.

*Plot normalization*: After the plot was fitted (and  $r_T$  and  $i_{T\infty}$  are determined) the plot can be shown in normalized coordinates. Check the options in the window

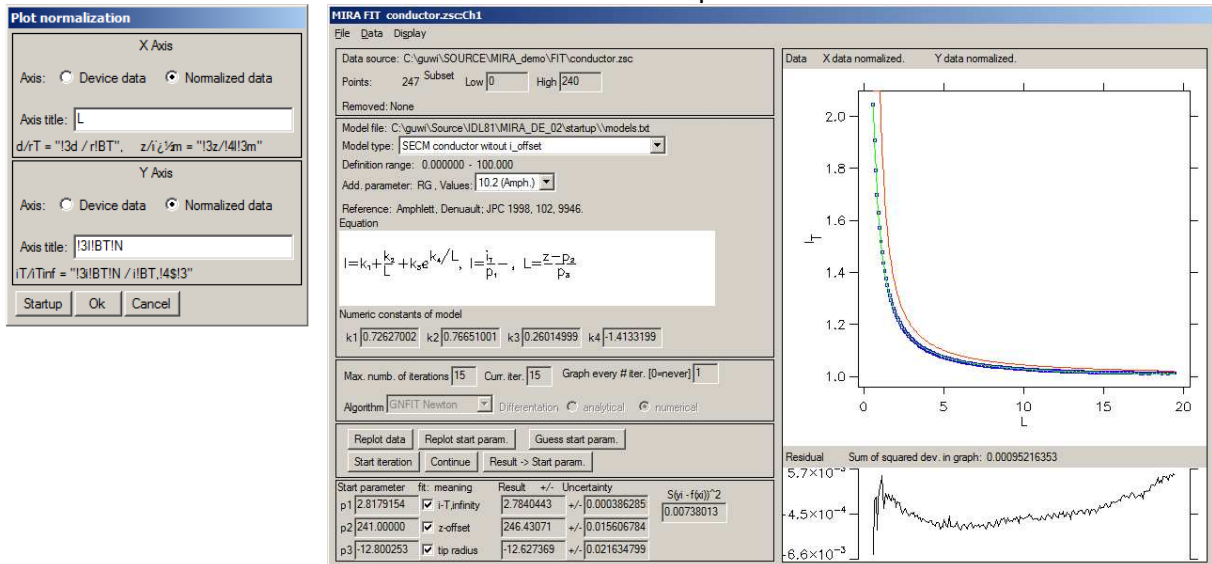

Fig. 122: Setting of the normalisation options (left) and resulting output (right). The title of the axis must be given with the formatting notation of IDL if special characters and superscripts and subscript are used. As a guideline, the notations for  $d/r_T$  and  $i_T/i_{T\infty}$  are given.

## 4 Multiplot

This configuration allows having a look at more than one plot at the same time (Standard initialization is given with 4 graphs for different data sets. → *Multiplot/Options/Change layout*). If you are not sure while loading the program either to choose *Single-* or *Multiplot*, you can change from *Single-* to *Multiplot* after starting working with the program. → *Single Plot/File/Start MULTIPLT*.

### 4.1 Elements of Multiplot

The general idea of multiplot is the following: Several data sets can be loaded into a filelist displayed on the left side of the Multiplot window.

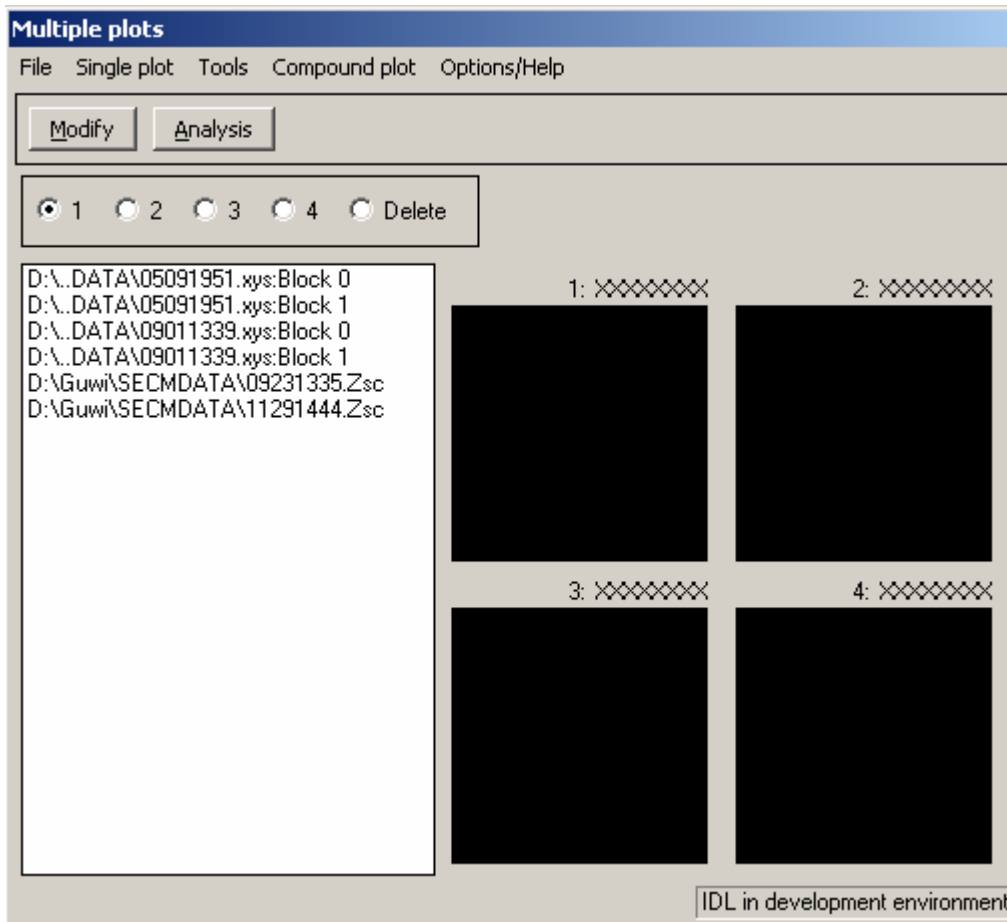

Fig. 123: Appearance of the *Multiplot* after loading some data sets.

Currently none of the data sets is actually loaded and can be worked with. To load a data, it must be loaded into one of the graph windows. To do so follow the following scheme

- 1) Select the graph window by either clicking on the option box in the selection tool on the right side OR click on the graph area itself.
- 2) Click on a data set within the list.

Once a graph window is selected you can continue clicking on data sets. They are then loaded into the graphic field. That is very convenient to get a fast overview on a

large number of measured data files. By selecting another graph more than one data set can be inspected. Please note: Only the data set selected last is the present data set with which manipulations can be done. If *Single Plot* and *Multiplot* are active at the same time, the active data set is always loaded into *Single Plot*.

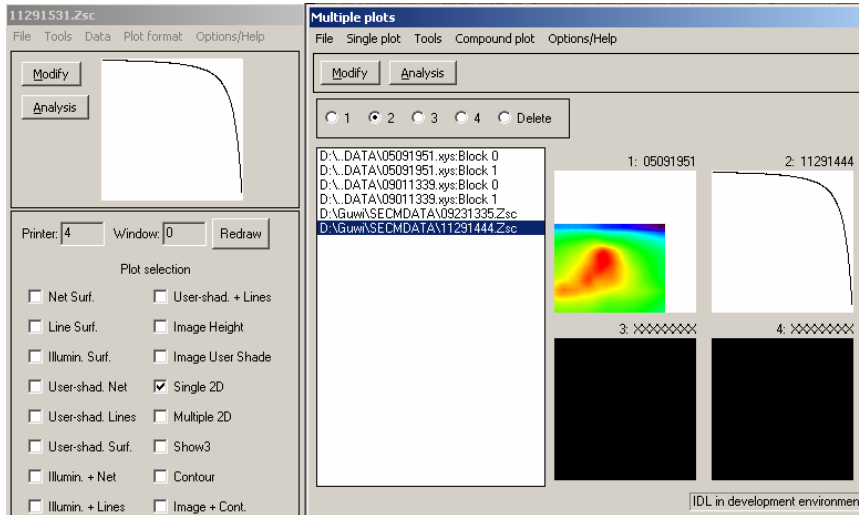

Fig. 124: *Multiplot* with two data sets loaded in graph 1 and 2. Only the data in graph two is the active data set (because 2 is selected in the selection tool and *Single plot* shows the 2D graph).

The active plot can be manipulated by the menu in *Multiplot* in a way very similar to *Single Plot*. User may also use *Single Plot* to make modifications to the graph display.

The display in *Multiplot* shows the pre-defined default plot for each data type. If formatting was changed, the changed format is shown if you click 2 times on the graph while the data set is highlighted in the file list of *Multiplot*. Often this display looks strange. But if they are plotted on normal sized windows, they look o.k.

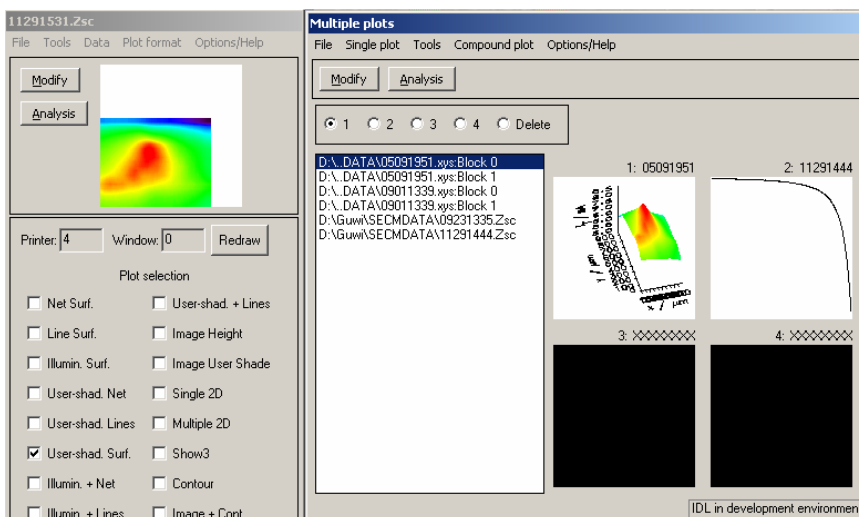

Fig. 125: *Multiplot* with two data sets loaded in graph 1 and 2. The plot type for data set 1 was changed in *Single Plot*. Clicking two times on graph region 1 in *Multiplot* displays the current graph in the graph field 1.

If a new data set is loaded into graph field 1, the old data together with all formatting informations are written to a temporary file. If this data set is loaded again later, the data will be recovered from that file.



By selecting "*Delete*" in the selection tool on the left and subsequently clicking on entries in the *File list*, the corresponding entry is deleted. Note that the last entry cannot be deleted in order to prevent an empty list. To do so load another data set and delete then the last entry of your previous selection.

Most options in the menu are the same as the ones which are explained in *Single Plot*. Here only those options are explained which are different to the *Single Plot*.

## 4.2 File

### 4.2.1 Add file to list

Selecting this menu item, you can select one or multiple file for reading into the file list. New files are appended at the end of the file list

### 4.2.2 Load from IDL binary

Here again you may select multiple files for loading.

### 4.2.3 File types

This function displays a spreadsheet with the initialisation data of each data set in the file list. Its main function is for debugging.

### 4.2.4 Change default path

-> *SinglePlot/File/Change default path*.

### 4.2.5 Selection of graphic format

-> *SinglePlot/Selection of graphic format*

### 4.2.6 Setup of windows printer

-> *SinglePlot/Setup of windows printer*

### 4.2.7 Print

-> *SinglePlot/Print*

### 4.2.8 Start SPM

SPM is a short cut of *Single Plot*. Starts *Single Plot*. If SPM is already active the command is quietly ignored.

### 4.2.9 Start batch interpreter

The batch interpreter is an important tool to increase the productivity when working with experimental data. It can perform typical operation with all data in the file list of *Multiplot* such as display on screen or creating a graphic file of a specific format. Batch interpreter can also be used to load a large number of files from a file list. Even sequences of operations can be performed by batch interpreter. Its main function in the author's group is to generate standardized printout for note books and archiving. Based on the printouts specific data sets can be selected for closer inspection.

The menu options within the batch interpreter are:

File/Load batch file:

This batch files allow for instance to load files from a list, make a printout of them and export the data to ASCII files. An example of a batch file is supplied in the installation path under `~/lib/example.bat`. (You may need to change paths before running it).

File/Change default path

As described for *Single Plot*.

File/Selection of graphic format

As described for *Single plot*

File/Close/open log file

Batch interpreter keeps a log file where all operations are noted. Such a log file can be closed and a new can be opened. The log file is written to `~/scratch`.

File/Exit

Returns to *Multiplt*.

Command/Make file list

Generates a file list from an input directory. The input directory can be selected using the path selection tool.

Command/Edit file list

Allows editing a file list formed by *Command/Make file list*. You enter a zero for those files that shall not be processed. Editing requires **<Enter>** when selecting the cell and **<Enter>** when confirming the change to the individual cell. Finally you confirm all changes. If you cannot see the full filename (with path), click on the cell, press **<Enter>** and scroll through the content of the cell. Recommendation: Use input path that contain only the data you want to process. This avoids somewhat inefficient editing of input files.

Command/Load file list

Selects a file with a file list. All data sets contained in the files listed in the file list will be loaded into *Multiplot*. It is not required that the list file is in the same directory as the data files.

Command/File filter

This selects or unselects certain data sets which are loaded in *Multiplot*. If there are for example all data sets generated in one day. You want to make a printout of all data sets except line scans that contain only 2 or 3 points (because they were interrupted because of wrong settings) you can do here. You can restrict printing to only 3D images or cyclic voltammograms etc.

Command/Print

A printout with the default settings of the currently selected graph format is generated for each data set contained in the *File List* of *Multiplot*. Graphic files are written to the current output path.

Command/Export

All data sets contained in *File List* of *Multiplot* will be exported to ASCII.

Help

Not active in the moment.

In order to complete the printout for the notebook, follow the step-by-step instruction in Chapter Auxiliary Tools at the end of the manual.

#### 4.2.10 Start Combined Plot

This starts the window to produce combined plots, i.e. plots that merge information from several data sets such as overlay plots or surface plots, where the shading is taken from another data set.

→ Main Chapter Combined Plots.

#### 4.2.11 Start difference plot

This starts the window for extracting differences between images. For instance between forward and reverse images. This allows to treat two sequences of images.

→ Main Chapter Difference Plots.

#### 4.2.12 Exit

Exits *Multiplot*.

### 4.3 Single plot

Single Plot only applies to the present data set only. When changing the present data set operations have to be performed again for the new data set.

#### 4.3.1 Redraw

Pressing **<Redraw>** the selected plot will be presented in an extra window.

#### 4.3.2 Full path

The full path of the data file is displayed (Fig. 126).

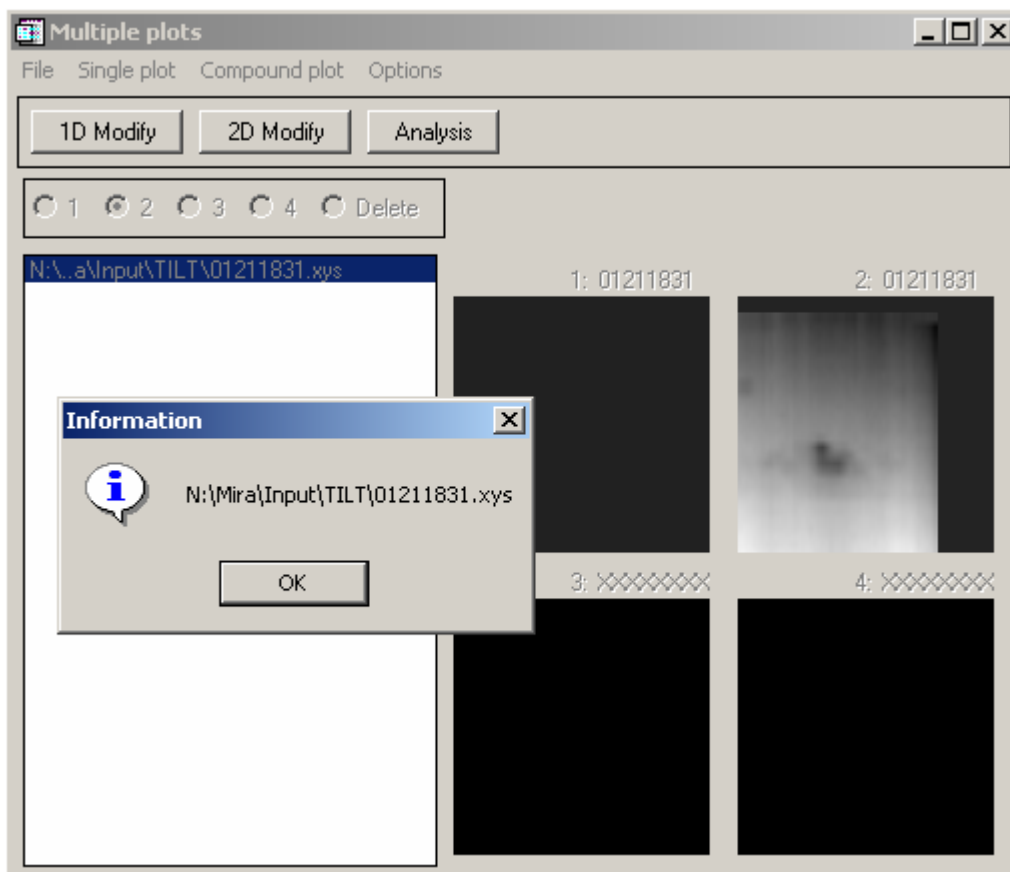

Fig. 126: Example for showing the path of a data set

### 4.3.3 Show header

→ *Single Plot/Tools/*

### 4.3.4 File

#### Save formatting

→ *Single Plot: File/Save Formatting*

#### Load formatting

→ *Single Plot: File/Load Formatting*

#### Save to IDL binary

→ *Single Plot: File/Save to IDL binary*

#### Export to ASCII

→ *Single Plot: File/Export to ASCII*

#### Print

→ *Single Plot: File/Print*

### 4.3.5 Data

#### Send data to Combined Plot

Transfers the present data set to the active set of Combined Plots

#### Send data do Difference Plot - Series 1

Transfers the data set to difference plots. It is listed under Series 1. This series may contain for example all forward images from an image sequence. Differences are always formed between corresponding images in Series 1 and Series 2.

→ Main Chapter Difference Plots.

#### Send data do Difference Plot - Series 2

Transfers the data set to difference plots. It is listed under Series 2. This series may contain for example all reverse images from an image sequence. Differences are always formed between corresponding images in Series 1 and Series 2.

→ Main Chapter Difference Plots.

#### Subsets

→ *Single Plot: Data/Subsets*

#### Resize array

→ *Single Plot: Data/ Resize array*

#### Arithmetics/X ~Y ~Z

→ *Single Plot: Data/ Arithmetics/X ~Y ~Z*

#### Data cutoff

→ *Single Plot: Data/ Data cutoff*

#### Rotate array

→ *Single Plot: Data/Rotate array*

### 4.3.6 Plot format

#### Handle volume data

Opens a tool to handle volume data. → *Single Plot: Handle volume data*

#### Create view

→ *Single Plot: Plot format/ Create view*

#### Plot dep. margin

→ *Single Plot: Plot format/Create view*

#### Plot region

Sets the limits of the plot region. This can be set here but will only affect Combined Plots. The position of the Single Plot is controlled only with the Plot-depending and hardware depending margins.

→ *Combined Plot: Example 2 - Create a Stacked Surface plot*

**Skirt**

→ *Single Plot: Plot format/Create view*

**Axis rotation**

→ *Single Plot: Plot format/Create view*

**Scale user shade**

→ *Single Plot: Plot format/Create view*

**Light source**

→ *Single Plot: Plot format/ Light source*

**Symbol**

→ *Single Plot: Plot format/Symbol*

**2D Line Color**

Sets the color for lines and symbols in 2D Plots. Than can be used to distinguish data sets in Combined Plots. A graphical selection tool opens with the color palette of the currently selected palette.

**Font system**

Allows selection of the font and font system. → *Single Plot: Format/Plot System*.

**4.3.7 Axis/X ~/Y ~/Z**

→ *Single Plot/Plot format/Axis/x ~/Y ~/Z*

**4.4 Tools****XLoadct**

The color table is selected. The new color is used for all subsequent graphs. The data sets that were treated before are saved together with the color table that was active when the processing was made.

**Xpalette**

The color table is edited. The new color is used for all subsequent graphs. The data sets that were treated before are saved together with the color table that was active when the processing was made. Pleas note, that the edited color table is used for graph output. The new color table will not be available if *Multiplot* is loaded gain.

**iSurface**

The current data set is used and *iSurface* is called (*Single Plot: Tools/iSurface*). Works only for 3D data sets.

**iSurface (shaded)**

The current data set is used and *iSurface (shaded)* is called (*Single Plot: Tools/iSurface (shaded)*). Works only for 3D data sets.

**iContour**

The current data set is used and *iContour* is called (*Single Plot: Tools/iContour*). Works only for 3D data sets.

**ilimage**

The current data set is used and *ilimage* is called (*Single Plot: Tools/ilimage*). Works only for 3D data sets.

**iPlot**

The current data set is used and *iPlot* is called (*Single Plot: Tools/iPlot*). Works only for 2D data sets.

## 4.5 Options + ?

### 4.5.1 Change layout

Change the number of graph fields and the size of the graph fields. Defaults are 2x2 and 128x128 pixels.

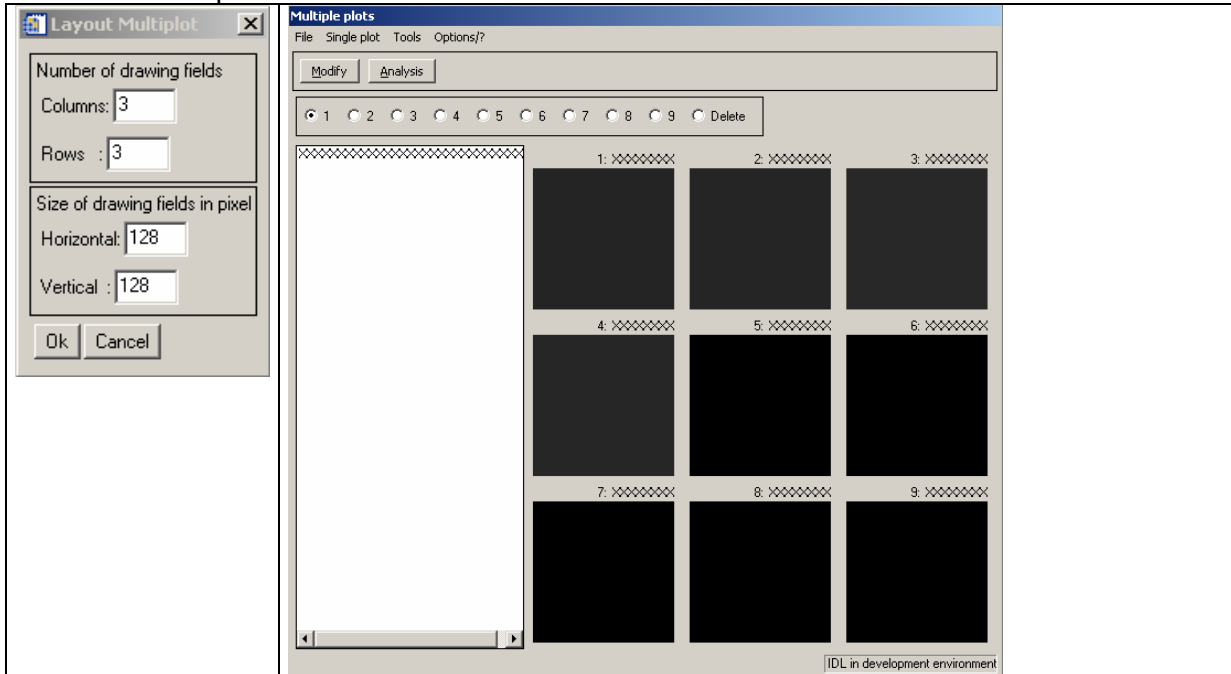

Fig. 127: Layout of *Multiplot*. Here the setting of a 3x3 layout with 128x128 pixels for each graph is shown. The right shows the resulting layout of *Multiplot*.

### 4.5.2 Save layout

This saves the current layout. This layout will become the new default layout when *Multiplot* is started again.

### 4.5.3 Load INI file

→ *Single Plot: Options/?/Load INI file*

### 4.5.4 Save INI file

→ *Single Plot: Options/?/Save INI file*

### 4.5.5 Information about MIRA

→ *Single Plot: Options/?/Information about MIRA*

### 4.5.6 What's new in MIRA VM 1.0

→ *Single Plot: Options/?/What's new in MIRA VM 1.0*

### 4.5.7 Manual about MIRA

→ *Single Plot: Options/?/Manual about MIRA*

### 4.5.8 RSI Manual about iTools

→ *Single Plot: Options/?/RSI Manual about iTools*

## 4.6 Menu Modify

The functions of this menu apply to the active data set and they are identical to the one in *Single Plot*.

## 4.7 Analysis

The functions of this menu apply to the active data set and they are identical to the one in *Single Plot*.

# 5 Combined Plot

Combined Plot allows generating graphs containing information of more than one data set. For 2D data sets these are overlay plots. Combined Plots of 3D data sets are designed primarily to deal with shear force SECM data. For instance the topography is shown as a surface or contour plot and the Faradaic current is shown as a false color scale of the surface or as an overlaid image of the contour plot. Another application are time sequences where the same region was imaged several times. The same number of data points must exist in all data sets. You should be proficient in making plots of individual data sets. This manual cannot cover all possible combinations and complications. Contact the author for specific requests.

In order to limit the possible ways of arranging and manipulating the data, the following general steps must be followed: Prepare and format the individual data sets in *Multiplot* or *Single Plot*. Then transfer the formatted data set from *Multiplot* to *Combined Plot*. If you need to change formattings, do so in *Multiplot* than transfer the data set again (The old version will be overwritten).

Some formattings (rotation angle of axes, margins around the plot) are taken from the first data set (shown in drawing area 1 in *Combined Plot*). There is limited possibility to change those settings in *Combined Plot*. The changes should be made in *Multiplot* and then the data set transferred to *Combined Plot*. **However, with this all settings you might have done in *Combined Plot* are overwritten!** There are two settings that are conveniently made in *Combined Plot*:

*Combined Plot: Plot format/Plot region* (needed for stacked surfaces)

*Combined Plot: Plot Format/Stacked Surf. common settings.* (needed for stacked surfaces)

Both will be explained in Example 2.

After all data sets are transferred, you can produce the *Combined Plots*. Printing to files follows the same principles as elsewhere in MIRA. The procedure is detailed here for combined surface plots and stacked surfaces. For other plots the suggestion should be followed analogously.

## 5.1 Example 1: Creating a combined Surface plots

Load the required data sets into Multiplot

Start Combined Plots from Multiplot: *Data/Start combined plot.*

Select the data set that is the topography. Select the data subset, rotation etc. Modify the formatting of the axis in Multiplot or Single Plot.

In Combined Plot: Set the number of data sets to be combined (2 is the default). If a value different from 2 is selected, use **[Refresh]** to rebuild the Combined Plots form.

In Combined Plot: Select the draw area 1 to receive the next data set by clicking on the draw area or using the radio button at the bottom of the window (Fig. 128a).

In Multiplot: Make sure the data set is formatted and selected as the active data set. Select Multiplot: *Single Plot/Data/Send Data to Combined Plot.*

The data set will appear in the draw area 1 of Combined Plot (Fig. 128b).

In Combined Plot: Select the draw area 2 by clicking on the draw area or using the radio button at the bottom of the window.

In Multiplot: Select the data containing the electrochemical currents.

In Multiplot or Single Plot: Format the data set with respect to the desired user color scaling → *Single Plot: Plot format/Scale user shade*

In Multiplot or Single Plot: Make sure an identical subset has been selected as in the data set transferred to draw area 1 in Combined Plot.

In Multiplot: Transfer the data set to drawing area 2 by selecting *Single Plot/Data/Send Data to Combined Plot*

In Combined Plots: Select **Combined Surf.** in the option field on the right side and press **[Redraw]**. A plot appears where the topography of the surface is made by the data in drawing area 1 and the color shade is a false color representation of the data in dataset 2 (Fig. 129).

The color scale can be suppressed if in Multiplot the drawing of the z-axis of the second data set is suppressed → *Single Plot/Axis/z.*

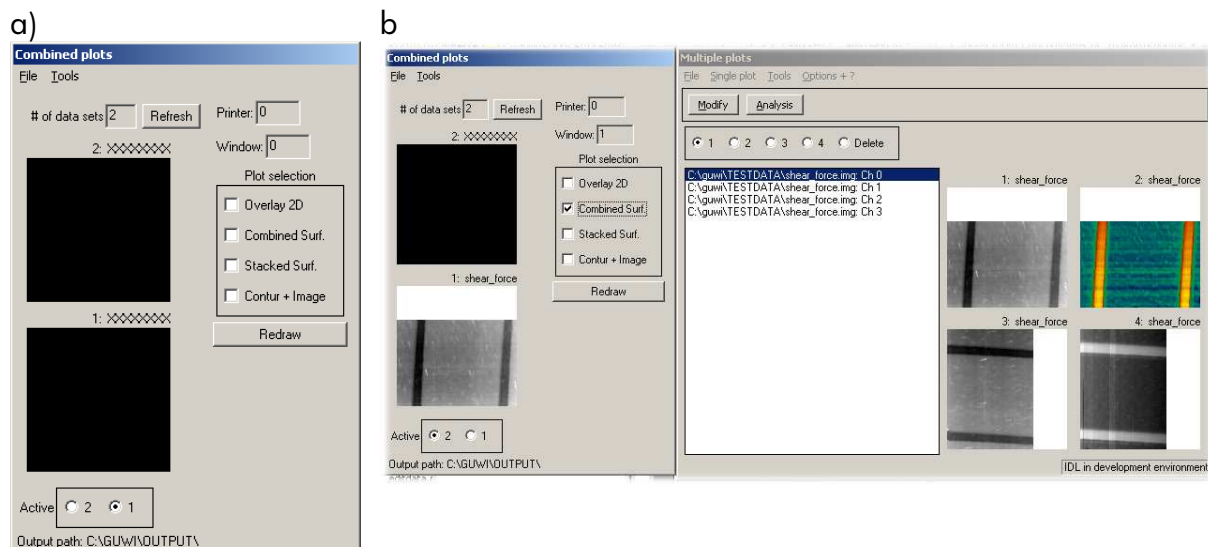

Fig. 128: Combined Plot form. a) Appearance after start, draw area 1 will receive the next data set. b) The first data set has been received into draw area 1 and will be used to construct the topography of the combined plot (or the contour map). Its information will be used for the x and y axes. The next data set will be received in draw area 2 (indicated by the radio button below the draw area).



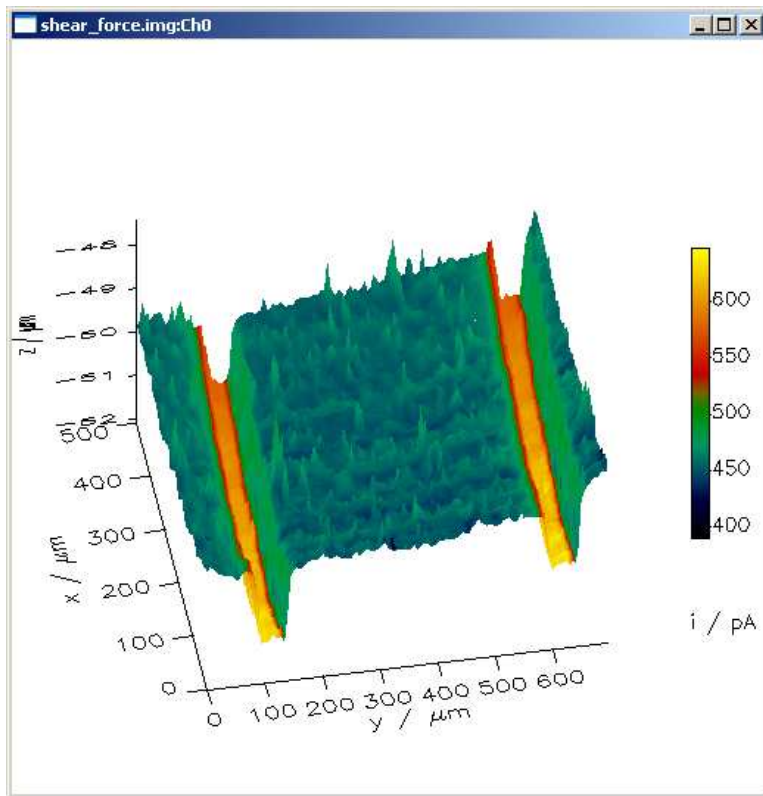

Fig. 129: Example of a combined plot from a shear force image (supplied in the demo data set). The topography is shown on the z scale in  $\mu\text{m}$ . The current is shown as false color with the scale to the right.

## 5.2 Example 2: Create a Stacked Surface plot

Stacked surface plots can be used for instance to represent shear force data or a sequence of images or different properties recorded at the same sample location. More than 2 data sets can be combined.

### 5.2.1 General background: placing multiple plots on a page

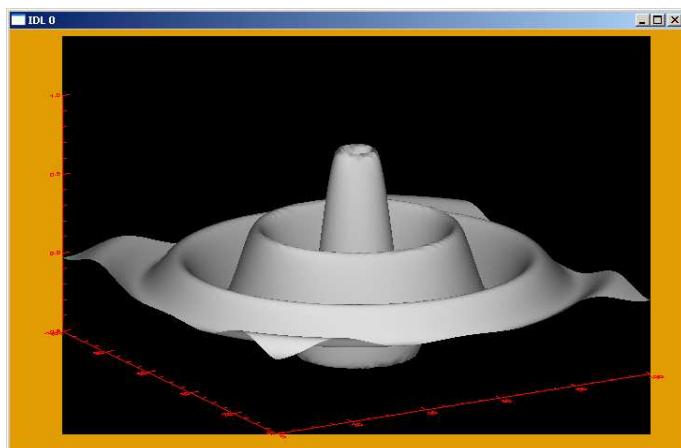

Fig. 130: Definition of the Plot window (black rectangle) and the margins (orange). The plot region comprises the Plot Window (Black) plus the axes and annotations.

In order to produce stacked surfaces, you should understand how IDL places plots on a printing page (e.g. the draw area of a graphic window or the page of an EPS file.). Figure 130 shows a 3D surface plot. The orange background is the page (e.g. the

drawing area of the window). The black rectangle is called the "Plot Window" which should not be confused with the window as defined by the operating system. The Plot Window contains the actual data points (excluding the axes and annotation). For surfaces plots the Plot Window is still rectangular and may contain part of the axes. The area including the axes is called "Plot region". [Plot Windows and Plot Regions are given in normalized coordinates of the lower left and upper right corner, i.e. as fractional numbers between 0 and 1.](#) In addition plot positions are manipulated by the margin keyword that controls how much space is available for tick marks and axis labels, e.g. the width of the orange margins around the black rectangle on Fig. 130. [Margins are given in multiples of character width.](#) This can be difficult to predict. It is advisable to play with this parameter, if the default settings do not produce a satisfying output. This can happen because the character width also depends on the output device. The properties of margins plot regions and plot windows are not independent from each other. They also affect how background colors are assigned during drawing. The Plot Window will always be drawn in the background color of the currently selected color table.

### 5.2.2 Use of plot regions for stacked surface

MIRA uses normally in single plot the margins to control the plot positions. The plot region is always left to its default, i.e. (0,0) - (1,1).

For stacked surfaces this is not sufficient and for each surface the plot region must be set in order to place the plots one atop the other. In order to align the z axes of different plots in one vertical line restrictions apply. [For the first data set, the horizontal and vertical limits of the plot regions are used. For the other data sets the user can only modify the lower vertical limit of the Plot Region.](#) The horizontal limits and margins are taken as identical to the first data set. The height of the plot affects the way the graphic transformations are made and has to be again identical to the first data set (you may not use the entire range of the z axis if you would like to give the plot a flat appearance).

In order to produce a good appearance one would like to place the stacked surfaces as close as possible above each other but avoid overdrawing one surface by the other. Unfortunately, the black rectangle in Fig. 130 will always be filled by the (opaque background color and cannot be fully used by two plots. Figure 131 shows a stacked surface plot with the two drawing regions indicated by transparent rectangles. Careful inspection of the lower left corner of the upper image shows that the plot was just clipped a little bit by the lower, although the actual surfaces are still far from overlapping. You should also change the format of the plot window or output size to file to have a portrait orientation (larger vertical size).

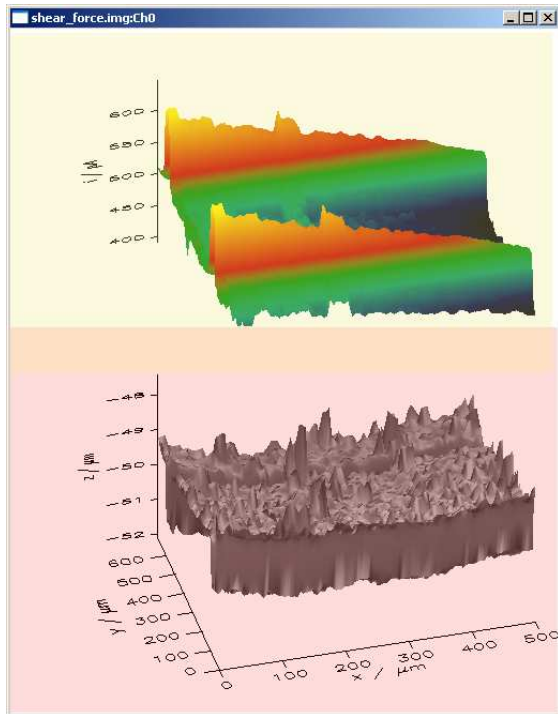

Fig. 131: Plot regions for a stacked surface plot. In the example the plot regions were (0, 0)-(1, 0.57) for the first plot and (0, 0.43)-(1, 1) for the second plot.

### 5.2.3 Fine adjustment of plot regions

Selecting the plot regions might not be easy and therefore MIRA can make suggestions upon request using Combined Plot: *Plot format/Stacked surf. common settings* (Fig. 132). The color tables provided by IDL do not have identical background and line colors. The first 2 options make sure that the background and line colors of the first plot are also used by the other plots. These options should be left in almost all cases. The option to remove exists because in rare cases it might be that the background color appears (unintentionally) in the plot itself.

The size of the labelling of the z axis follows the same idea. It uses the settings of the first plot for all plots. (Remember, if you reload the first plot, that will change the settings for all other plots).

The last option makes IDL to suggest plot regions for all plots. They can than be refined by using **[Redraw]** and setting the plot region limits individually with the tool Combined Surface: *Plot format/Plot region* (Fig. 133). The first selected surface plot, (i.e. the one used for the stacked surface will be highlighted. The regions can be adjusted

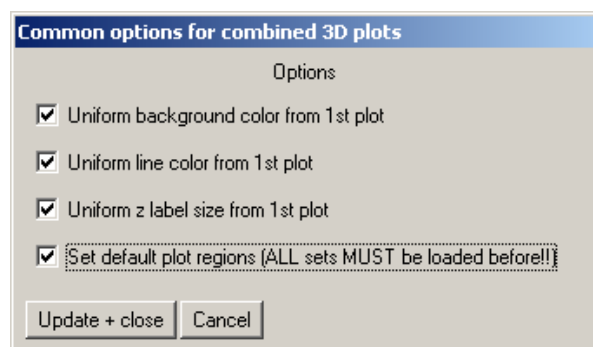

Fig. 132: Tool for setting common background colors and suggesting plot regions.

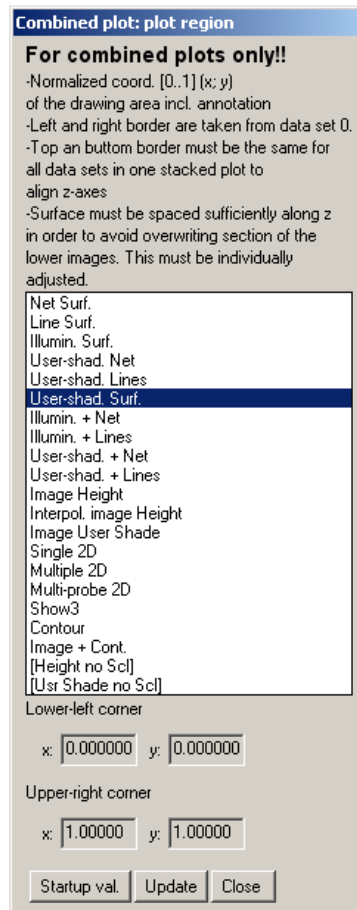

Fig. 133: Tool for selecting the limits of the plot regions individually. It will affect only stacked surfaces. For the first data set all fields are editable, for the other data sets only the lower limit of the plotting regions is editable. The other values are copied from the first data set.

### 5.2.4 Optimizing a stacked surface plot

The following steps describe how to produce the data of Fig. 131 into an optimized version (Fig. 134).

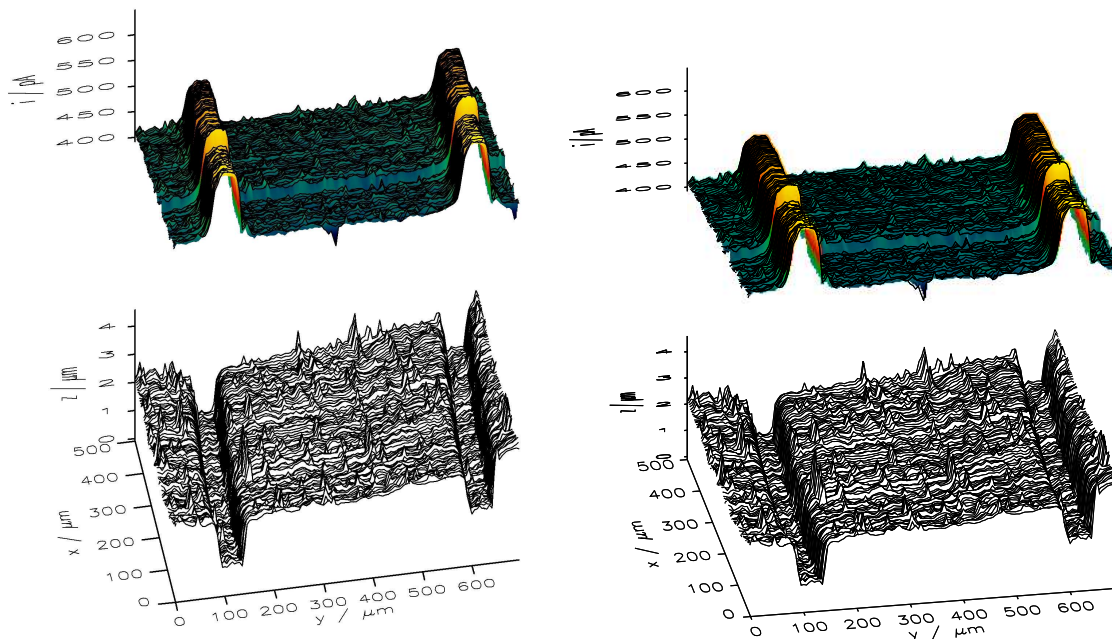

Fig. 134: Optimized stacked surface (left as jpg and right as eps).

Load the required data sets into Multiplot. It is supplied as demo data set ([Installation path]\demo\SHEAR\_FORCE\shear\_force.img)

Start Combined Plots from Multiplot: *Data/Start combined plot.*

Start Single plot for convenient formatting.

Select the data set that is the topography (first list entry) in Multiplot. Make the following modification in Single Plot: Select line plot as plot type. Use *Data/Arithmetics/z axis*. Set  $C = 52$  to shift the data range ( $z/\mu\text{m}$ ) from -52 to -48 to the range 0 to 4. Rotate data set by  $90^\circ$ . Set the axis rotation angles to  $70^\circ$  and  $10^\circ$ . Set in *Plot format/Axis format/z* the character size factor to 1.6. In Multiplot or Single Plot: Select the color table (Single Plot: *Tool/XLoadct* select B-W Linear).

Select another data set and switch back to the topography data (this step makes sure that a temporary data file with the formatting information is created).

In Combined Plot: Set the number of data sets to be combined (2 is the default). If a value different from 2 is selected, use **[Refresh]** to rebuild the Combined Plots form.

In Combined Plot: Select the draw area 1 to receive the next data set by clicking on the draw area or using the radio button at the button of the window (Fig. 128a).

In Multiplot: Make sure the topography data (first entry) is selected as the active data set. Select Multiplot: *Single Plot/Data/Send Data to Combined Plot.*

The data set will appear in the draw area 1 of Combined Plot (Fig. 128b).

In Combined Plot: Select the draw are 2 by clicking on the draw area or using the radio button at the button of the window.

In Multiplot: Select the data containing the electrochemical currents (2nd list entry).

In Multiplot or Single Plot: Select the color table (Single Plot: *Tool/XLoadct* select Blue/Green/Red/Yellow). Rotate the array by  $90^\circ$ . Select *User-shad. + Lines* Format the data set with respect to the desired user color scaling → *Single Plot: Plot format/Scale user shade*. Select register tab Line by line, select the option *Plane fit vertical to x axis* (important after the rotation!). Select *Use scan average*.

In Combined Plot: *Select Stacked Surf.* .

In Combined Plot: *Plot format/Stacked Surf. common settings*. Click on all options (Fig. 132), **[Redraw]**.

In Combined Plot: *File/Select plot format*: make the screen output to 512 wide and 640 high; **[Redraw]**.

In Combined Plot: *File/Select plot format*: select JPG, make the output to 1536 wide and 1920 high. Make the output file (*File/Print*).

**Known problems** For EPS a portrait plot aspect ratio is obtained only if the plot region horizontal values are changed for instance to 0.15 to 0.85.

There is the option of further processing graphic files with graphic programs like Coral Draw or Adobe Photoshop. This allows changing the background, adding labels and moving the plotting areas closer together.

## 6 Difference Plot

The tool Difference plot is started von Multiplot in the menu *File/Start difference plot*. The example data sets are located in the path ...\\demo\\difference.

### 6.1 Loading Data

The tool Difference Plot contains two Series to accept data sets. The differences are calculated between data set 1 of Series 1 vs. data set 1 of Series 2, data set2 of Series 1 vs. dataset 2 od Series 2 and so on. Currently only images can be processed. All data sets must be loaded from Multiplot. First load the datasets into Multiplot using Multiplot: *File/Add file to list*. The files appear in the list of Multiplot. Select a data set that you want to send to Difference Plot (Fig. 135).

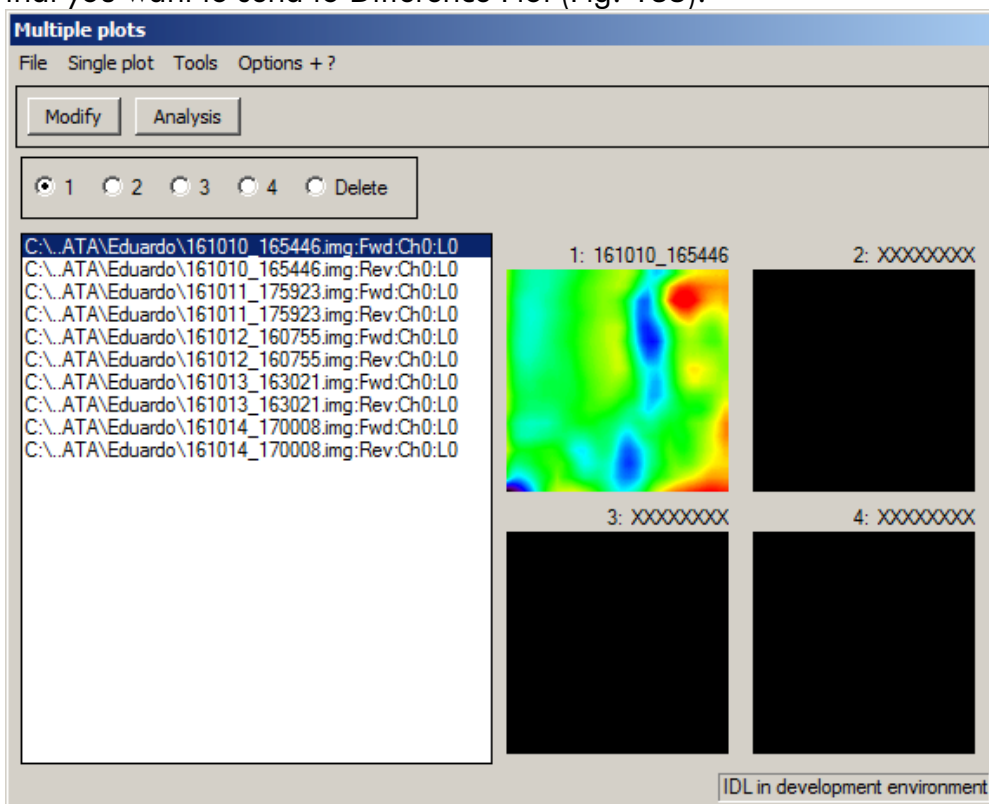

Fig. 135: Multiplot file list from which data are transferred to Difference Plot.

To send a data set to Series 1 in Difference Plot, select a data set, select from the menu in Multiplot *SinglePlot/Data/send to Difference Plot - Series 1*. If Difference Plot had not been started before, it will be started, the data set appears as first entry in the upper list in Difference Plot.

To send a data set to Series 2 in Difference Plot, select a data set, select from the menu in Multiplot *SinglePlot/Data/send to Difference Plot - Series 2*. If Difference Plot had not been started before, it will be started, the data set appears as first entry in the lower list in Difference Plot.

## 6.2 Exploring and adjusting data sets in Difference Plot

Continue in this way until all data sets that should be compared are transferred. The Difference Plot should look like Fig. 136. By clicking on different data sets they will be shown as gray-scale images in the drawing areas next to the list. In this way it can be checked that the correct data sets have been loaded. Data sets can be removed from each list by the **<Delete>** button above the list. The order within the list can be changed by selecting a data set and using the **<Up>** and **<Down>** button above the lists.

A data set can be loaded multiple times, for instance if several images shall be compared to one reference image.

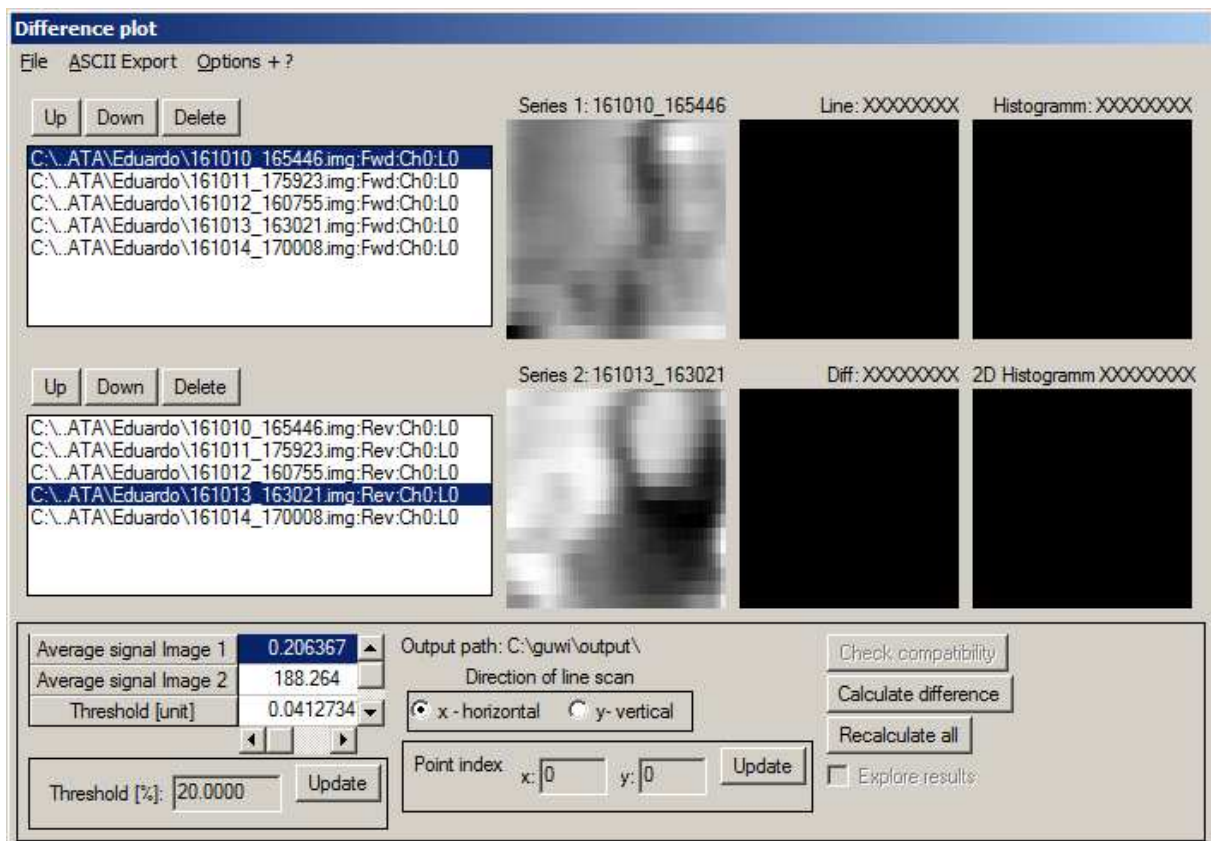

Fig. 136 Appearance of Difference Plot after loading 5 data sets in Series 1 and 5 data sets in Series 2.

After loading the list, one should check the compatibility of the data sets. The data sets should have the same number of points. If adjustments are required this should be done before loading them into Difference Plot. If point spacings are small integer multiples in Series 1 and Series 2, Difference plot attempts to deal with this situation. All datasets within one series must have the same dimensions. If this test has been passed successfully, the **<Check compatibility>** button is disabled and the **<Calculate difference>** and **<Recalculate all>** buttons are enabled.

## 6.3 Principle of calculation in Difference Plot

The program calculates differences between pairs of images. It also provides a statistics about those difference images. It counts significant differences between the two data sets. A difference is significant, when the data point of the image in Series 2

is outside the interval (Image 1 data point - threshold, Image 1 data point + threshold). In order to account for slowly decreasing signals in image sequences over long time, the threshold can be given in % of the mean signal value of the current image in Series 1 in the text field in the low left column below the lists with the data sets. This procedure has for instance been used to compare SECM images of solid electrolyte interfaces in lithium ion batteries over long period of time and to identify changes that occur on different time scales.<sup>1</sup>

The **<Update>** button will update the new relative threshold. The absolute threshold is shown for each activated image in the table above the text field in the left part of the window. After selecting an appropriate threshold.

After these preparation, one may try **<Recalculate all>**. The program will calculate the difference images for each pair of data sets (Fig. 137, lower middle plot) count the significant differences in each pair and plot them in a histogram (Fig. 137, upper right plot)

It will also count how often a statistic difference occurs at a particular image position within the entire series of data. The data are shown as a color-coded, two-dimensional histogram (Fig. 137, lower right plot)

After the calculation it switches to the explore mode (checkbox in the right column below the plots).

---

<sup>1</sup> a) H. Bülter, F. Peters, J. Schwenzel, G. Wittstock; Spatiotemporal Changes of the Solid Electrolyte Interphase in Lithium-Ion Batteries Detected by Scanning Electrochemical Microscopy. *Angew. Chem. Int. Ed.* 2014, 53, 10531-10535; b) H. Bülter, F. Peters, J. Schwenzel, G. Wittstock; Comparison of Electron Transfer Properties of the SEI on Graphite Composite and Metallic Lithium Electrodes by SECM at OCP. *J. Electrochem. Soc.* 2015, 162, A7024-A7036; c) H. Bülter, F. Peters, G. Wittstock; Scanning Electrochemical Microscopy for the In Situ Characterization of Solid Electrolyte Interphases: Highly Oriented Pyrolytic Graphite vs. Graphite Composite. *Energy Technol. (Weinheim, Ger.)* 2016 4, 1486-1494.



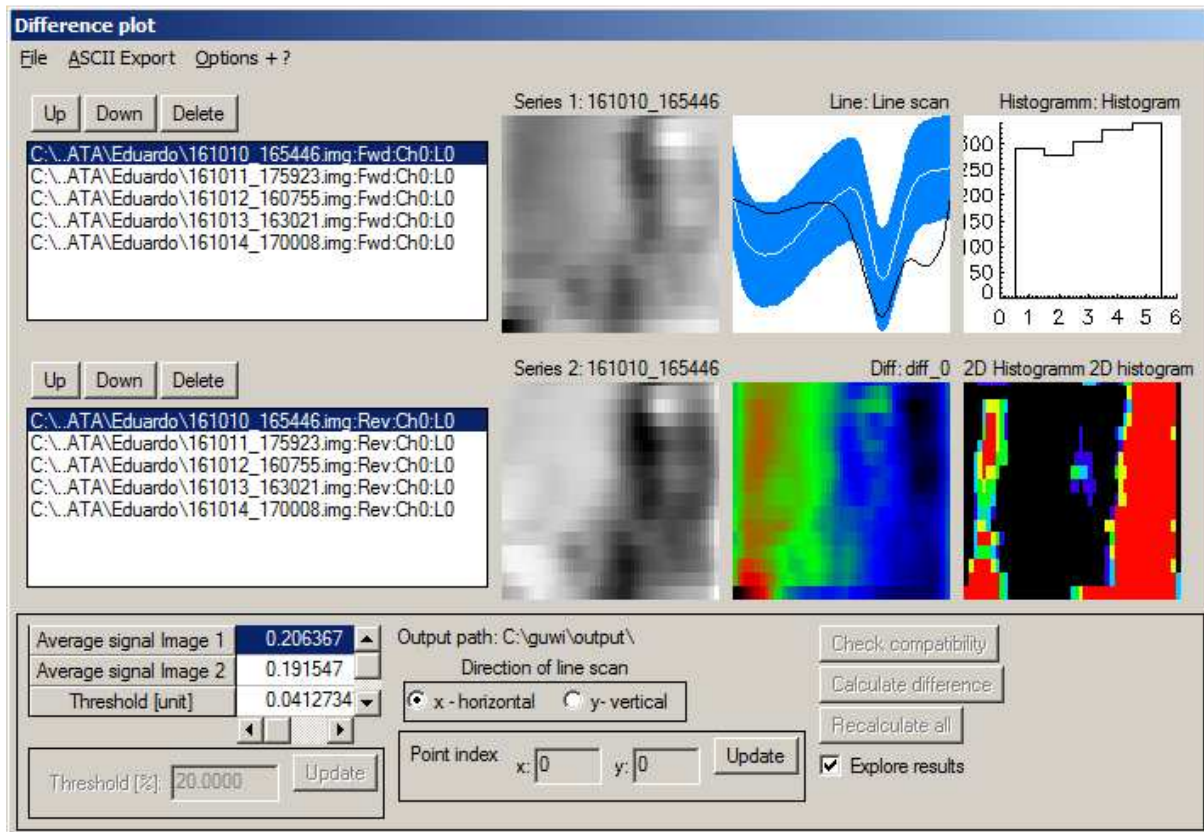

Fig. 137: Appearance of Difference Plot after execution of **<Recalculate all>**.

## 6.4 Exploring results in Difference Plot

After calculation the results can be explored in Difference Plot, exported to ASCII tables or exported back to SinglePlot or Multiplot for further processing and plotting. Plotting in Difference Plot is not possible.

### 6.4.1 Exploring pair of data sets

By clicking on a data set in the upper or lower list, the paired data set in the alternative list is also selected and the difference image for that pair is loaded into the lower middle plot. Currently color scales are fixed but this could be changed upon strong needs. For the moment it is recommended to export a particular difference plot to Single Plot and then adjust colors there (see below).

### 6.4.2 Exploring line scan within one pair of images

By clicking on either of the for images, a point in the image is selected. The pending on the radio button x-horizontal or y-vertical a horizontal or vertical linecan through the selected point is cut from the images of the particular pair and plotted in the topi middle plot together with a ribbon around the line scan from Series 1. The width of the ribbon corresponds to the threshold value applied in making the statistics for significant deviations between the pair of images.

### 6.4.3 Recalculate with a new threshold

In order to make the statistics with another threshold, deactivate the exploration mode by un-selecting the check box *Explore results*. The different elements are activated again. A new threshold can be entered, **<Update>** and a new calculation can be made.

## 6.5 Use of the Button Calculate difference

After the compatibility of the data sets was confirmed by **<Check compatibility>** this button allows also to calculate differences between data sets that are out of sequence, e.g. image 1 or Series 1 vs. image 3 of Series 2. The difference plot is shown but no histograms are calculated.

## 6.6 Exporting the result and handling of the menu in Difference Plot

### 6.6.1 File formats for results

For the further use of the results, they must be transferred to SinglePlot. They can be then saved to the internal MIRA data format (\*.sav files) or exported to ASCII files.

Note on \*.sav files: These files contain all data and the formatting information and can be written/retrieved very efficiently. These files can only be read by MIRA. Even more so, because their internal structure may change with every update of MIRA, they are specific for a particular version of MIRA. Therefore, this file type is for intermediate storage only. Long time storage, e.g. of data used for publication, should be made in ASCII format (without formatting information).

To save data as \*.save file:

- 1) In DifferencePlot, select *File/Return ... data* (SinglePlot will start if not open already)
- 2) in SinglePlot *File/save to IDL binary*
- 3) Retrieve later to Single Plot by starting SinglePlot and then *File/Load from IDL binary*

To save data as ASCII file

- 1) in Difference Plot, select *ASCII Export/Export ...*

The program will ask for a file name and save the file in one of several formatting options.

- 2) The data can be retrieved to MIRA for further processing by starting SinglePlot and then *File/Import from ASCII*

### 6.6.2 Menu structure in Single Plot

*File/Change default path*

Changes file path to which data are written

*File/Return selected line scans to XSPM*

It transfers the line scans in the top middle plot to SinglePlot. Note that the last displayed plot is used. If no explicit selection of the point was made, this data set may contain senseless data.

This mode is only available in explore mode.

*File/Return selected difference image to XSPM*

It will return the last valid or the selected difference image to SinglePlot (middle lower image). The difference plot is selected by clicking on the file lists  
This mode is only available after calculation.

*File/Return histogram to XSPM*

It will return the histogram (upper right plot) to SinglePlot.  
This mode is only available in explore mode.

*File/Return 2D histogram to SinglePlot*

It will return the 2D histogram (lower right plot) to SinglePlot.  
This mode is only available in explore mode.

*ASCII Export/Exported selected line scan*

It makes an ASCII file with the data line scans in the top middle plot.  
This mode is only available in explore mode.

*ASCII Export/Exported selected difference image*

It makes an ASCII file with the difference image in the lower middle plot.  
This mode is only available after calculation.

*ASCII Export/Exported histogram*

It makes an ASCII file with the histogram in the top right plot.  
This mode is only available in explore mode.

*ASCII Export/Exported 2D histogram*

It makes an ASCII file with the 2D histogram in the lower right plot.  
This mode is only available in explore mode.

*Options+?/Set and save layout*

Difference Plot has 6 drawing areas. By default they are 128 by 128 pixels. In order to change the size of the drawing area, start DifferencePlot, select Options/Set and save layout, enter new value for horizontal (x) and vertical (y) size. Then close Difference Plot and start it again. Now the new sizes come into effect.

*Options+?/Manual Difference Plot*

Shows this text as a short menu for Difference Plot.

## 7 Auxiliary tools

### 7.1 MIRA\_VM\_02\_2003.XLS and MIRA\_VM\_02\_2010.XLS

The MS Excel files *MIRA\_VM\_02\_20??*.XLS are supplied in the root of the installation. *MIRA\_VM\_02\_2003.XLS* is made for Excel2003 and earlier and *MIRA\_VM\_02\_2010.XLS* is made for Excel2010.

They can be copied to any path on your machine. You are free to modify the code in it. The code is made in VBA.

The purpose of this tool is to generate output of many data files for a quick overview and documentation. This printout is optimized for laboratory notebooks and is designed as a graphical directory. It may look as the following page.

The *MIRA\_VM\_02\_2003.xls* and *MIRA\_VM\_02\_2010.xls* worksheets are optimized for interaction with *MIRA\_VM\_02*. It will not function with very old versions of MIRA.

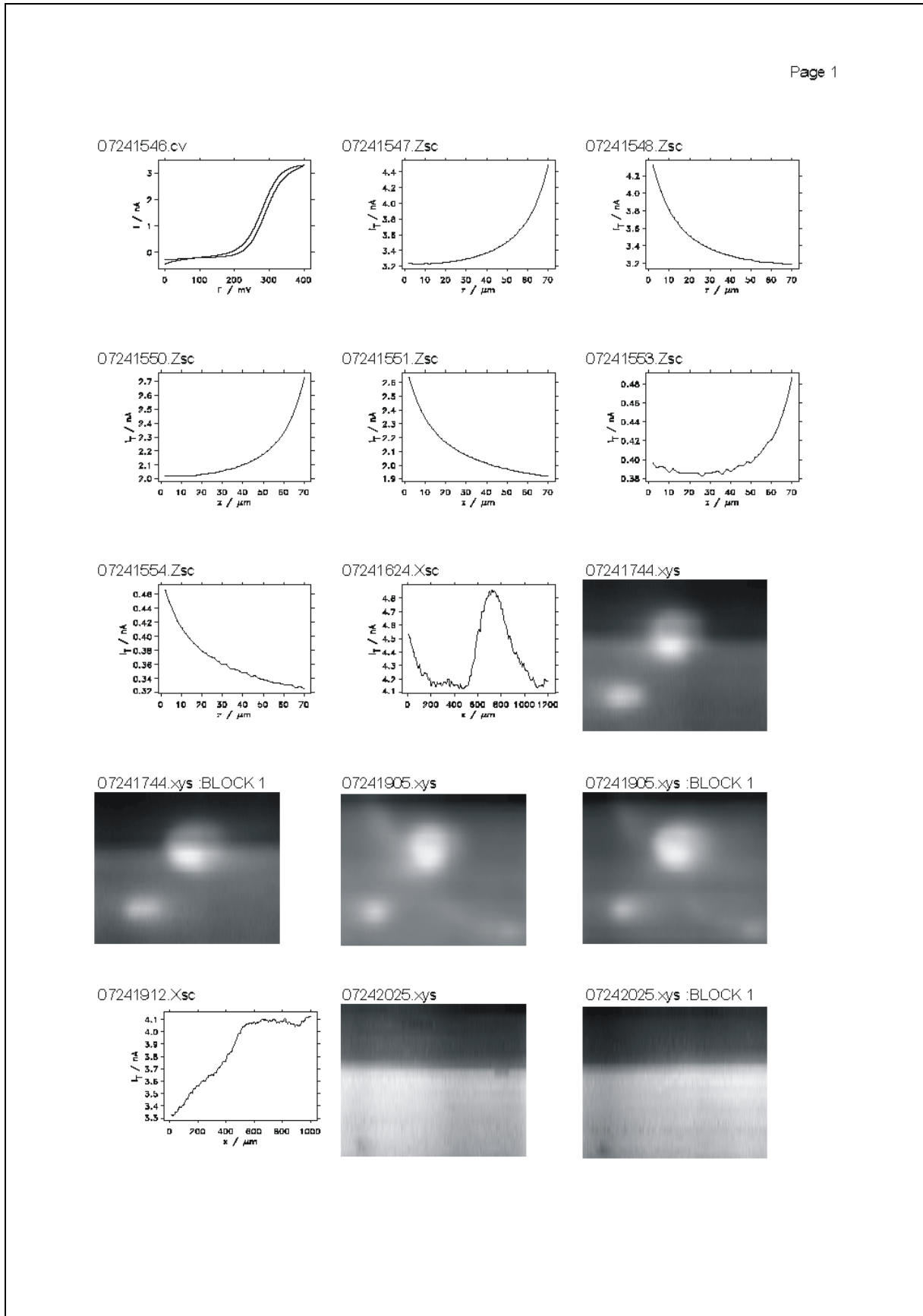

Fig. 138: Printout generated from mira.xls

## 7.2 Generating a lab book printout with MIRA\_VM\_02 and MIRA\_VM\_02\_????.xls

The first part consists in loading all the data files into the file list of *Multiplot*. There are different ways to do this. They are described in the following section

1. **Empty the input directory** or create a new empty subdirectory of you preferred input directory. Load your all your measurement **data files into the input directory** or the new subdirectory.

2. Empty your output directory.

3. **Start MIRA**. In the startup section select *Multiplot* and your preferred INI-file.

Now you can either proceed with steps 4 or 8 or 10. Combination of the different loading methods are possible as well.

4. **Start the *Batch Interpreter*** from *Multiplot File/Start batch interpreter*.

5. In the *Batch Interpreter* select *Command/Make file list*. Select the path, where your experimental data files are located. Confirm the settings by **<Ok>**. Select a name and a path for the file list to be generated. Recommendation: Use the input path to store the file list with the experimental data.

7. In the *Batch Interpreter* select *Command/Load file list*. Select the file list you have just created. All files in this file list will be loaded into *Multiplot*.

Proceed with step 13.

8. Load files into *Multiplot* with the menu *File/Add file* to list or *File/Load IDL binary*. Note that you can select multiple files. Files can be loaded from different directories.

9. **Start the *Batch Interpreter*** from *Multiplot File/Start batch interpreter*.

Proceed with step 13.

10. If **Single Plot** is running, you can load data from Single Plot with *File/Open file*, *File/Load IDL binary* or *File/Import ASCII*.

11. Transfer the data to *Multiplot* by *File/Add to MULTIPLT list*.

12. **Start the *Batch Interpreter*** from *Multiplot File/Start batch interpreter*.

Proceed with step 13.

13. From the *Batch interpreter* select the graphic file type from *File/selection* of graphic format. Select the output directory in *Batch interpreter File/Change default paths*.

14. From *Batch interpreter* select [Commands/Print](#). You will be asked for the name of an [output file list](#). This list will contain the full name (including path) of the graphic files and a descriptive short name of the data file (e.g. image.xys\_Block:1). This file will make the further work much easier. It can be placed anywhere. If you do not want to make such a file, select **<Cancel>** in the file selection box. A printout will be generated for each file and each data block in multi-image files. The printout will be made to your output directory.

15. Start [MS Excel](#).

If you use Excel 2003 or older, load the file [MIRA\\_VM\\_02\\_2003.XLS](#)

If you use Excel 2010, load the file [MIRA\\_VM\\_02\\_2010.XLS](#)

Both Excel files are provided in the installation directory of MIRA\_VM\_02. Confirm **<Makros aktivieren>** or **<Activate macros>**.

16. On the Excel worksheet press **<Clear old content>**.

17 On the Excel worksheet press **<Read file list>**, a file selection tool appears. You should select the output file list, which was created in step 14. The file list will be loaded. The file list appears underneath the three buttons in column E. In column D you have one entry of the name of the list file.

You may load more list files. They will be appended to the current list file.

18. On the Excel worksheet press **<Import graphic files>**. All graphic files will be imported and formatted. Postscript files will be displayed only as empty frames.

19. [Make a printout](#) using the printers installed on your computer. Only columns A to C will be printed. The printout should look like Fig. 138.

The printout is optimized for European A4 paper size. To change the size of the columns to adapt for US letter size go within the Excel on Excel/Macro/Visual basic editor. Go to the very top of the program listing. You find there 2 lines

```
Const col_width# = 29#  
Const picture_width# = 153#
```

Increase the values 29 and 153 to fit to your paper size.  
Repeat steps 15-19 until you are satisfied with the result.

Note: Imported PostScript files will only produce meaningful printouts if sent to a PostScript printer. If you are unsure whether you have a PostScript printer, consult your computer administrator.

Advice: If you have a PostScript printer, this should be the preferred file type. It can, of course, only be used if you have a PostScript printer available.

The whole sequence of steps 1-18 may take something like 3 minutes for 100 files. Printout of course depends on you computer, the performance of the printer and the type of connection from your PC to the printer.

